

# **Sorensen** XG and XTR Family Programmable DC Power Supply

Operating Manual  
(firmware v 2.0 and higher)  
670 Watts – 1700 Watts

Half Rack	Full Rack	
6 V to 600 V Models:		
6-110	6-220	6-220
8-100	8-187.5	8-200
12-70	12.5-120	12-140
20-42	20-76	20-84
33-25	30-50	33-50
40-21	40-38	40-42
60-14	60-25	60-28
80-10.5	80-19	80-21
100-8.5	100-15	100-17
150-5.6	150-10	150-11.2
300-2.8	300-5	300-5.6
600-1.4	600-2.6	600-2.8



## **About AMETEK**

AMETEK Programmable Power, Inc., a Division of AMETEK, Inc., is a global leader in the design and manufacture of precision, programmable power supplies for R&D, test and measurement, process control, power bus simulation and power conditioning applications across diverse industrial segments. From bench top supplies to rack-mounted industrial power subsystems, AMETEK Programmable Power is the proud manufacturer of Elgar, Sorensen, California Instruments and Power Ten brand power supplies.

AMETEK, Inc. is a leading global manufacturer of electronic instruments and electromechanical devices with annualized sales of \$2.5 billion. The Company has over 11,000 colleagues working at more than 80 manufacturing facilities and more than 80 sales and service centers in the United States and around the world.

## **Trademarks**

AMETEK is a registered trademark of AMETEK, Inc. Sorensen is a trademark owned by AMETEK, Inc. Other trademarks, registered trademarks, and product names are the property of their respective owners and are used herein for identification purposes only.

## **Notice of Copyright**

*XG and XTR Family Programmable DC Power Supply Operating Manual (firmware v 2.0 and higher) © 2008-2011 AMETEK Programmable Power, Inc. All rights reserved.*

## **Exclusion for Documentation**

UNLESS SPECIFICALLY AGREED TO IN WRITING, AMETEK PROGRAMMABLE POWER, INC. ("AMETEK"):

- (a) MAKES NO WARRANTY AS TO THE ACCURACY, SUFFICIENCY OR SUITABILITY OF ANY TECHNICAL OR OTHER INFORMATION PROVIDED IN ITS MANUALS OR OTHER DOCUMENTATION.
- (b) ASSUMES NO RESPONSIBILITY OR LIABILITY FOR LOSSES, DAMAGES, COSTS OR EXPENSES, WHETHER SPECIAL, DIRECT, INDIRECT, CONSEQUENTIAL OR INCIDENTAL, WHICH MIGHT ARISE OUT OF THE USE OF SUCH INFORMATION. THE USE OF ANY SUCH INFORMATION WILL BE ENTIRELY AT THE USER'S RISK, AND
- (c) REMINDS YOU THAT IF THIS MANUAL IS IN ANY LANGUAGE OTHER THAN ENGLISH, ALTHOUGH STEPS HAVE BEEN TAKEN TO MAINTAIN THE ACCURACY OF THE TRANSLATION, THE ACCURACY CANNOT BE GUARANTEED. APPROVED AMETEK CONTENT IS CONTAINED WITH THE ENGLISH LANGUAGE VERSION, WHICH IS POSTED AT [WWW.PROGRAMMABLEPOWER.COM](http://WWW.PROGRAMMABLEPOWER.COM).

## **Date and Revision**

January 2011 Revision A

## **Part Number**

M370430-01

## **Contact Information**

Telephone: 800 733 5427 (toll free in North America)  
858 450 0085 (direct)  
Fax: 858 458 0267  
Email: [sales@programmablepower.com](mailto:sales@programmablepower.com)  
[service@programmablepower.com](mailto:service@programmablepower.com)  
Web: [www.programmablepower.com](http://www.programmablepower.com)

## Product Family: XG and XTR Family Programmable DC Power Supply

Warranty Period: Five Years

### WARRANTY TERMS

AMETEK Programmable Power, Inc. ("AMETEK"), provides this written warranty covering the Product stated above, and if the Buyer discovers and notifies AMETEK in writing of any defect in material or workmanship within the applicable warranty period stated above, then AMETEK may, at its option: repair or replace the Product; or issue a credit note for the defective Product; or provide the Buyer with replacement parts for the Product.

The Buyer will, at its expense, return the defective Product or parts thereof to AMETEK in accordance with the return procedure specified below. AMETEK will, at its expense, deliver the repaired or replaced Product or parts to the Buyer. Any warranty of AMETEK will not apply if the Buyer is in default under the Purchase Order Agreement or where the Product or any part thereof:

- is damaged by misuse, accident, negligence or failure to maintain the same as specified or required by AMETEK;
- is damaged by modifications, alterations or attachments thereto which are not authorized by AMETEK;
- is installed or operated contrary to the instructions of AMETEK;
- is opened, modified or disassembled in any way without AMETEK's consent; or
- is used in combination with items, articles or materials not authorized by AMETEK.

The Buyer may not assert any claim that the Products are not in conformity with any warranty until the Buyer has made all payments to AMETEK provided for in the Purchase Order Agreement.

### PRODUCT RETURN PROCEDURE

1. Request a Return Material Authorization (RMA) number from the repair facility **(must be done in the country in which it was purchased)**:
  - **In the USA**, contact the AMETEK Repair Department prior to the return of the product to AMETEK for repair:  
Telephone: 800-733-5427, ext. 2295 or ext. 2463 (toll free North America)  
858-450-0085, ext. 2295 or ext. 2463 (direct)
  - **Outside the United States**, contact the nearest Authorized Service Center (ASC). A full listing can be found either through your local distributor or our website, [www.programmablepower.com](http://www.programmablepower.com), by clicking Support and going to the Service Centers tab.
2. When requesting an RMA, have the following information ready:
  - Model number.
  - Serial number
  - Description of the problem

**NOTE:** Unauthorized returns will not be accepted and will be returned at the shipper's expense.

**NOTE:** A returned product found upon inspection by AMETEK, to be in specification is subject to an evaluation fee and applicable freight charges.

# About This Manual (firmware v2.0 and higher)

## Purpose

The Operating Manual provides installation and operating information for the XG and XTR Family Programmable DC Power Supply.

## Scope

The Manual provides safety information, features and specifications, installation procedures, functional test procedures, and operating procedures for both local (front panel) operation and remote operation.

The Manual also provides information on the GPIB interface option and LXI compliant Ethernet (ENET) interface for models with the MEB and MEA options.

## Audience

The Manual is intended for the user who is familiar with electronic power supplies, Constant Voltage and Constant Current operating modes, and the control of output power. The user should be familiar with practicing safe techniques while making supply or pin connections.

## Conventions Used

The following conventions are used in this guide.



### **WARNING**

Warnings identify conditions or practices that could result in personal injury or loss of life.

---



### **CAUTION**

Cautions identify conditions or practices that could result in damage to the unit or other equipment.

---

**Important:** Important notes provide information that is important for you to know. They are not as serious as Warnings or Cautions.

---

## Related Information

More information about AMETEK Programmable as well as its products and services, is available at [www.programmablepower.com](http://www.programmablepower.com).

## Acronyms

Acronym	Definition
APG	Analog Programming
AUX	Auxiliary
ENET	Ethernet
FGA	Finished Goods Assembly
ISOL	Isolated Analog Programming
OCP	Over Current Protection
OTP	Over Temperature Protection
OVP	Over Voltage Protection
PSU	Power Supply Unit
TVS	Transient Voltage Suppressor
UVP	Under Voltage Protection

## Font Conventions

This Manual uses the following typographical conventions:

<code>7 SE97E7E</code>	For display and readback information on the output voltage and current displays.
Command body text	Represents SCPI commands.

# Important Safety Instructions



## **WARNING: High energy and high voltage**

Exercise caution when using a power supply. High energy levels can be stored at the output voltage terminals on a power supply in normal operation. In addition, potentially lethal voltages exist in the power circuit and on the output and sense connectors of a power supply with a rated output greater than 40 V. Filter capacitors store potentially dangerous energy for some time after power is removed.



## **WARNING: Fire hazard**

Operate the power supply in an environment free of flammable gases or fumes. To ensure that the power supply's safety features are not compromised, use the power supply as specified in this Manual and do not substitute parts or make any unauthorized modifications. If service is necessary, please return the power supply to the Authorized Service Center. See the Warranty on page ii.



## **WARNING: Limitations on use**

The XG and XTR Family Programmable DC Power Supply is not intended for use in connection with life support systems or other medical equipment or devices.



## **CAUTION: For use as a battery charger**

When you are using a power supply for battery charging applications, it is essential to provide an appropriately sized fuse or circuit breaker in series between the power supply output and the battery. Installation of a protector (fuse or DC circuit breaker), rated for about 115% of the maximum current rating of the power supply and designed specifically to interrupt the DC voltage of the battery, will provide adequate current protection. Where several power supplies are in parallel, it is best to fuse each power supply rather than use one fuse at the battery.

---

## Power Supply Safety Markings



Alternating Current



Earth (Ground) Terminal



Protective Conductor Terminal



On (Supply)



Off (Supply)



Caution (Check the Manual for additional information.)

## Standard Warnings



---

### **WARNING: Keep these instructions**

This chapter contains important safety and operating instructions. Read and keep this Operating Manual for future reference.

---

1. Before installing and using the XG and XTR Family Programmable DC Power Supply, read all instructions and cautionary markings on the instrument and all appropriate sections of this Manual.
2. This instrument is for indoor use only. Do not expose the instrument to moisture. To reduce risk of fire hazard, do not cover or obstruct the ventilation openings. Be sure to install the instrument in a compartment which allows air to reach the ventilation inlets on the front and rear of the unit to prevent overheating. For more information, see “Ventilation” on page 2-4.
3. To avoid a risk of fire and electric shock, make sure that the existing wiring is in good condition and the wire is not undersized. Do not operate the instrument with damaged or substandard wiring.
4. Do not operate the instrument if it has received a sharp blow, been dropped, or otherwise damaged in any way. If the instrument is damaged, see the Warranty on page ii.
5. Do not disassemble the instrument. It contains no user-serviceable parts. See the Warranty on page ii for instructions on obtaining service. Attempting to service the instrument yourself may result in a risk of electrical shock or fire. Internal capacitors remain charged after all power is disconnected.
6. To reduce the risk of electrical shock, disconnect AC power from the instrument before attempting any maintenance or cleaning or working on any circuits connected to the instrument. Turning off controls will not reduce this risk.



# Contents

<b>1 Introduction.....</b>	<b>1-1</b>
Features and Options.....	1-2
XG and XTR Models (firmware version 2.0 and higher).....	1-3
Front Panel .....	1-5
Front Panel Display and Controls .....	1-6
Rear Panel Connectors on 850 Watt Models.....	1-7
Rear Panel Connectors on 1500 and 1700 Watt Models.....	1-9
<b>2 Installation.....</b>	<b>2-1</b>
Basic Setup Procedure.....	2-2
Step 1: Inspecting and Cleaning .....	2-3
Initial Inspection.....	2-3
Periodic Cleaning .....	2-3
Step 2: Location and Mounting .....	2-4
Rack Mounting.....	2-4
Purchasing Rack Mount Kits .....	2-4
Ventilation .....	2-4
Step 3: Connecting AC Input Power.....	2-5
XG/XTR 850 Watt AC Input Connector .....	2-5
XG/XTR 1500 and 1700 Watt AC Input Connector .....	2-6
XG/XTR 1500 and 1700 Watt AC Input Wire.....	2-6
XG/XTR 1500 and 1700 Watt AC Input Wire Connection.....	2-7
Step 4: Selecting Load Wires .....	2-8
Load Wiring.....	2-8
Insulation Rating .....	2-8
Current Carrying Capacity.....	2-8
Maximum Load Wiring Length For Operation With Sense Lines.....	2-9
Noise and Impedance Effects.....	2-9
Step 5: Performing Functional Tests.....	2-10
Powering the Power Supply On/Off.....	2-10
Voltage and Current Mode Operation Checks .....	2-11
Step 6: Connecting Loads.....	2-12
DC Output Connectors .....	2-12
Inductive Loads and Batteries.....	2-13
Connecting Single Loads .....	2-14

Connecting Multiple Loads.....	2-14
Step 7: Connecting Remote Sensing.....	2-15
<b>3 Local Operation.....</b>	<b>3-1</b>
Introduction	3-2
Configuring Settings from the Front Panel.....	3-2
Using the 9-Position Mode Control.....	3-2
Using the Rotary Adjust/Enter Control .....	3-2
Coarse and Fine Adjustment Modes.....	3-3
Navigating the Menu System.....	3-5
Setting VOLTS and AMPS Modes .....	3-5
Normal Display Mode and Inactivity Timeout .....	3-7
Display Messages on the Front Panel .....	3-9
Standard Operation .....	3-12
Operating Modes .....	3-12
Shipped Configuration (Local Operation) .....	3-16
Enabling the Output .....	3-16
Enabling the Auxiliary Output .....	3-17
Output Auto Start Mode (Auto Restart).....	3-17
Auxiliary Auto Start Mode.....	3-18
Alarms and Errors.....	3-19
Clearing Alarms .....	3-20
Front Panel ALARM LED.....	3-21
Alarm Masking.....	3-22
Alarm Output Latching.....	3-23
Setting Foldback Mode .....	3-24
Resetting Activated Foldback Protection.....	3-25
Using Over Voltage Protection (OVP).....	3-26
Defining the OVP Set Point .....	3-27
Using Under Voltage Protection (UVP).....	3-28
Defining the UVP Set Point.....	3-29
Over Current Protection (OCP) .....	3-29
Using Over Temperature Protection Lock (OTP).....	3-30
Defining the OTP Mode .....	3-30
Resetting in Latch Mode.....	3-30
Using the External Shutdown Function.....	3-31
Activating the External Shutdown Function.....	3-31
Controlling the External Shutdown Function.....	3-31
Defining the Polarity of the External Shutdown Signal.....	3-32

---

Interlock Function.....	3-33
Defining the Interlock Mode.....	3-33
Output Protection.....	3-33
Programming Voltage Output Preset.....	3-33
Programming Current Output Preset .....	3-34
Power On Status Signal .....	3-35
Hardware Malfunction Alarms .....	3-35
Current Configuration Memory Settings.....	3-36
User Setting Memory Locations .....	3-37
Saving User Setting Memory Locations .....	3-37
Recalling User Setting Memory Locations .....	3-38
Local Lockout.....	3-39
Enabling Local Lockout .....	3-39
Disabling Local Lockout .....	3-39
Resetting the Power Supply.....	3-40
Using Multiple Power Supplies .....	3-42
Configuring Multiple Supplies for Series Operation.....	3-44
Configuring Multiple Supplies for Current Sharing Operation (APG Method).....	3-47
Connecting to the Load in Local Sensing Mode (Parallel Control Method).....	3-49
Connecting to the Load in Remote Sensing Mode (Parallel Control Method) .....	3-50
<b>4 Analog Programming (APG) and Isolated Analog Programming (ISOL).....</b>	<b>4-1</b>
Introduction .....	4-2
Analog Programming (APG) of Output Voltage and Output Current .....	4-2
Remote Programming Options.....	4-3
Analog Programming (APG) Connector J1 .....	4-5
Analog Programming Mode .....	4-9
Analog Programming With External Voltage Source .....	4-9
Voltage-Controlled Voltage APG Setup.....	4-10
Voltage-Controlled Current APG Setup .....	4-12
Resistive-Controlled Voltage APG Setup.....	4-15
Resistive-Controlled Current APG Setup .....	4-17
Voltage and Current Readback .....	4-19
Isolated Analog Programming Mode (ISOL) .....	4-20
AUX Output and Isolated Analog Programming (ISOL) Connector .....	4-20
Voltage-Controlled Voltage ISOL Setup.....	4-23
Voltage-Controlled Current ISOL Setup .....	4-25
Resistive-Controlled Voltage ISOL Setup.....	4-28

Resistive-Controlled Current ISOL Setup .....	4-30
Voltage and Current Readback (Isolated) .....	4-32
<b>5 Remote Operation</b> .....	<b>5-1</b>
Introduction .....	5-2
Hardware and Connection Setup .....	5-2
Configuring Remote Control Using RS-232.....	5-2
Configuring Remote Control Using RS-485.....	5-7
Configuring Remote Control using the USB Connector .....	5-9
Setting Up the PC to Use the USB Connection.....	5-9
GPIB Connector (Optional) .....	5-15
Ethernet/LAN (ENET) Connector (Optional).....	5-18
Multiple Power Supply Connections to RS-485 Bus .....	5-19
Terminal Configuration.....	5-21
Data Format .....	5-21
End of Message .....	5-21
HyperTerminal .....	5-21
Selecting the Appropriate Communication Port .....	5-24
Multichannel Address Setting.....	5-25
Remote Interface Addressing.....	5-26
Multichannel Commands Explained .....	5-27
Status Reporting in SCPI.....	5-29
Status Registers Model from IEEE 488.2 .....	5-31
Status Byte .....	5-32
Error/Event Queue (ERR).....	5-32
Questionable Status Register Summary (QSR).....	5-32
Message Available (MAV).....	5-33
Standard Event Status Summary (ESB).....	5-33
Master Summary Status (MSS).....	5-33
Request Service (RQS).....	5-33
Operation Status Register Summary (OSR).....	5-34
Standard Event Status Register (SESR) .....	5-35
Standard SCPI Register Structure.....	5-38
OPERation Status Register.....	5-39
Current SHare Sub-Register .....	5-42
Operation Status Register Commands .....	5-43
Current Sharing Sub-Register Commands.....	5-44
Shutdown Sub-Register Commands .....	5-45
Protection Sub-Register Commands.....	5-46

---

QUESTIONable Status Register .....	5-47
VOLTagE Sub-Register .....	5-50
TEMPerature Sub-Register.....	5-50
Questionable Status Register Commands .....	5-51
Voltage Status Register Commands .....	5-52
Temperature Status Register Commands.....	5-53
SCPI Error/Event Queue .....	5-54
Reset Command .....	5-56
Clear All Status Registers.....	5-57
SCPI Preset Status.....	5-58
Command Line Help System .....	5-59
Locking and Unlocking the Front Panel.....	5-62
Auto Sequence Programming .....	5-62
Configure Other Protection Mechanisms .....	5-69
Foldback Protection.....	5-69
Over Temperature Protection.....	5-70
Interlock Enable/Disable.....	5-70
Save and Recall.....	5-71
Set Analog Programming Level.....	5-71
Set Remote Programming Interface .....	5-71
Protection Mask (Enable Alarms) .....	5-73
Power Saving Control (Sleep Mode, XTR/XG 1700 W Only).....	5-74
<b>6 Communications Options.....</b>	<b>6-1</b>
Introduction .....	6-2
Setting Up XG/XTR 850 Watt Models .....	6-2
Basics.....	6-2
Network Topology and Connection .....	6-5
Software Installations .....	6-8
Configuring the Device Using DeviceInstaller .....	6-10
Terminal Configuration .....	6-17
Advanced Section.....	6-24
Network Topology 1: Simple LAN.....	6-24
Network Topology 2: ENET and RS-485 Bus.....	6-28
Troubleshooting for XG/XTR 850W Model with ENET and/or RS-485 Communication .....	6-30
Setting Up XG/XTR 1500 and 1700 Watt Models.....	6-31
Local Area Network (LAN) Option.....	6-32
Media Access Control (MAC) Address.....	6-32

Communication Configuration.....	6-32
LAN Connection .....	6-32
Direct-to-PC Connection .....	6-32
Private Network Connection.....	6-33
AMETEK LXI Discovery Browser .....	6-33
Installing the AMETEK LXI Discovery Browser.....	6-34
Using the AMETEK LXI Discovery Browser .....	6-41
AMETEK EnetTest Utility.....	6-42
Installing the AMETEK EnetTest Utility .....	6-42
Using the AMETEK Ethernet Test Utility.....	6-48
Setting LAN Parameters.....	6-49
Setting LAN Parameters via Ethernet.....	6-49
Setting LAN Parameters via Serial or USB Port.....	6-50
Setting LAN Parameters via Web Interface.....	6-50
Connecting to a Network.....	6-54
Connecting with PC on Same Side of Router as Power Supply.....	6-55
Connecting with Power Supply Hidden Behind a Router.....	6-57
Socket Port Number.....	6-60
Instrument Drivers and Application Software.....	6-61
System Commands.....	6-62
Subsystem Syntax .....	6-62
LXI Compliance .....	6-65
Introduction to the LXI Standard .....	6-66
VXI Discovery .....	6-66
LAN Requirements.....	6-66
Web Page.....	6-66
Remote Procedure Calls (RPC).....	6-67
Drivers .....	6-67
<b>7 Calibration and Troubleshooting .....</b>	<b>7-1</b>
Introduction 7-2	
Main Voltage and Current Calibration Principle.....	7-3
Understanding the Problem.....	7-3
Step 1: Gain Calibration .....	7-4
Step 2: Offset Calibration .....	7-4
Step 3: Recalibrate Gain .....	7-5
Calibrating the Output Voltage.....	7-6
Gain Calibration.....	7-6
Offset Calibration.....	7-6

---

Calibrating the Output Current .....	7-7
Gain Calibration .....	7-7
Offset Calibration .....	7-8
Over Voltage Protection Calibration.....	7-9
Non-isolated Analog Programming Calibration .....	7-10
Non-isolated Voltage Monitoring Calibration .....	7-10
Non-isolated Current Monitoring Calibration.....	7-11
Non-isolated Voltage Programming of Voltage Calibration.....	7-12
Non-isolated Resistive Programming of Voltage Calibration.....	7-13
Non-isolated Voltage Programming of Current Calibration .....	7-14
Non-isolated Resistive Programming of Current Calibration .....	7-15
Calibration Procedure for Isolated Modes.....	7-16
Isolated Voltage Monitoring Calibration .....	7-16
Isolated Current Monitoring Calibration .....	7-17
Isolated Voltage Programming of Voltage Calibration .....	7-18
Isolated Resistive Programming of Voltage Calibration .....	7-19
Isolated Voltage Programming of Current Calibration.....	7-20
Isolated Resistive Programming of Current Calibration.....	7-21
Calibrating the Input Voltage APG Signal .....	7-22
Calibrating the Input Current APG Signal.....	7-23
Storing and Loading Calibration Parameters.....	7-25
Restore Factory Calibration.....	7-26
Restore Default Calibration.....	7-26
User Diagnostics .....	7-26
Emergency Shutdown.....	7-27
Unusual or Erratic Operation .....	7-27
Troubleshooting for Operators.....	7-28
<b>A SCPI Command Reference .....</b>	<b>A-1</b>
SCPI Conformance Information .....	A-2
Codes and Standards.....	A-2
IEEE 488.2/SCPI Syntax and Style.....	A-2
SCPI Command Hierarchy .....	A-3
Using SCPI Commands .....	A-4
Parameter Types.....	A-7
SCPI Command Tree .....	A-8
SCPI Command Summary.....	A-14
<b>B Error Messages .....</b>	<b>B-1</b>
Error Messages .....	B-2

Command Error List.....	B-3
Execution Error List .....	B-4
Device-Specific Error List.....	B-5
Query Error List.....	B-6
<b>C Specifications .....</b>	<b>C-1</b>
Electrical Specifications for XG/XTR Family.....	C-2
AC Line Input Specifications for XG/XTR 850 Watt.....	C-3
Electrical Specifications for XG/XTR Family.....	C-4
AC Line Input Specifications for XG/XTR 1500 Watt.....	C-5
Electrical Specifications for XG/XTR Family.....	C-7
AC Line Input Specifications for XG/XTR 1700 Watt.....	C-8
Remote Operation.....	C-9
Common Specifications for All Models.....	C-10
<b>D Rack Mount Options and Installation Instructions.....</b>	<b>D-1</b>
Rack Mount Kit Options .....	D-2
XG/XTR Single (Half Rack) and Dual (Full Rack) .....	D-2
Location Requirements.....	D-3
Mounting Option A: 1U Rails .....	D-4
Tools and Materials Required.....	D-4
Installation Procedures.....	D-4
Mounting Option B: Manufactured Slides from Jonathan® Engineered Solutions.....	D-6

## Figures

Figure 1-1 XG/XTR Front Panels .....	1-5
Figure 1-2 Front Panel Display and Controls.....	1-6
Figure 1-3 XG/XTR 850 Watt Units: 6 V to 40 V Models.....	1-7
Figure 1-4 XG/XTR 850 Watt Units: 60 V to 150 V Models.....	1-7
Figure 1-5 XG/XTR 850 Watt Units: 300 V to 600 V Models.....	1-7
Figure 1-6 XG/XTR 1500 and 1700 Watt Units: 6 V to 40 V Models.....	1-9
Figure 1-7 XG/XTR 1500 and 1700 Watt Units: 60 V to 600 V Models.....	1-10
Figure 2-1 1500 and 1700 Watt AC Input Cover and Strain Relief .....	2-6
Figure 2-2 Maximum Load Wire Length for 1 V Line Drop.....	2-9
Figure 2-3 Diode Placement.....	2-13
Figure 2-4 Connecting Single Loads .....	2-14
Figure 2-5 Remote Sense Connection .....	2-15



---

Figure 3-1	9-Position Mode Control.....	3-2
Figure 3-2	Front Panel Menu System.....	3-8
Figure 3-3	Operating Modes .....	3-14
Figure 3-4	Split Supply Operation.....	3-43
Figure 3-5	Series Operation .....	3-45
Figure 3-6	Load Connections in Remote Sensing Mode .....	3-46
Figure 3-7	Load Connections in Local Sensing Mode .....	3-49
Figure 3-8	Load Connections in Remote Sensing Mode (Parallel Control Method).....	3-50
Figure 4-1	APG Connector Terminals.....	4-5
Figure 4-2	Inserting Screwdriver into Spring Terminal Block.....	4-7
Figure 4-3	APG and DC Output Connector .....	4-7
Figure 4-4	Programming Output Voltage using an External Voltage Source.....	4-9
Figure 4-5	Programming Output Current using an External Voltage Source .....	4-9
Figure 4-6	Programming Output Voltage using an External Resistor .....	4-14
Figure 4-7	Programming Output Current using an External Resistor .....	4-14
Figure 4-8	Voltage Readback Using APG Connector J1.....	4-19
Figure 4-9	Current Readback Using APG Connector J1 .....	4-19
Figure 4-10	AUX Output and ISOL Connector Pinout .....	4-20
Figure 4-11	Programming Output Voltage using an Isolated External Voltage Source.....	4-22
Figure 4-12	Programming Output Current using an Isolated External Voltage Source .....	4-22
Figure 4-13	Programming Output Voltage using an Isolated External Resistor .....	4-27
Figure 4-14	Programming Output Current using an Isolated External Resistor .....	4-27
Figure 4-15	Isolated Voltage Monitoring .....	4-32
Figure 4-16	Isolated Current Monitoring.....	4-32
Figure 5-1	Remote Control Connectors.....	5-3
Figure 5-2	RS-232 Communication Cable with DB-9 Pinout.....	5-5
Figure 5-3	DB-25 Pinout .....	5-5
Figure 5-4	RS-232 Communication Cable with DB-25 Pinout.....	5-6
Figure 5-5	RS-485 Communication Cable with DB-9.....	5-7
Figure 5-6	RS-485 Communication Cable from Master to Slave Unit.....	5-8
Figure 5-7	Found New Hardware Wizard.....	5-10
Figure 5-8	Install Hardware Device Drivers .....	5-10
Figure 5-9	Completing the New Hardware Wizard.....	5-11
Figure 5-10	Device Manager .....	5-12
Figure 5-11	Communications Port (COM1) Properties.....	5-13
Figure 5-12	Completing the new hardware wizard .....	5-13
Figure 5-13	Scanning for Instruments .....	5-17
Figure 5-14	Instrument Properties.....	5-18

## Contents

---

Figure 5-13	Multi Power Supply Connection to RS-485 Bus.....	5-19
Figure 5-14	USB Settings .....	5-22
Figure 5-15	ASCII Setup .....	5-23
Figure 5-16	SCPI Status Reporting Model .....	5-30
Figure 5-17	IEEE 488.2 Register Model .....	5-31
Figure 5-18	summarizes the Standard Event Status Register.....	5-36
Figure 5-19	SCPI Register Model .....	5-38
Figure 5-20	Operation Status Register Fanout .....	5-39
Figure 5-21	SCPI QUEStionable Registers Fanout.....	5-48
Figure 6-1	Computer or HUB Plug .....	6-3
Figure 6-2	Power Supply Plug .....	6-3
Figure 6-3	RJ-45 Plug.....	6-4
Figure 6-4	Scheme of ENET Cross-Cable.....	6-4
Figure 6-5	XPort® ENET Connector and LEDs.....	6-5
Figure 6-6	Single Computer, Single Power Supply.....	6-6
Figure 6-7	Configuring the Network Connection of the Computer.....	6-6
Figure 6-8	LAN Properties Dialog Box.....	6-7
Figure 6-9	Internet Protocol (TCP/IP) Properties Dialog Box .....	6-8
Figure 6-10	DeviceInstaller Setup Wizard.....	6-9
Figure 6-11	Select Installation Folder Window .....	6-10
Figure 6-12	Multiple Network Adapters.....	6-11
Figure 6-13	Selecting Network Adapter .....	6-12
Figure 6-14	Auto-IP Address Message.....	6-12
Figure 6-15	Searching for Power Supply IP Address.....	6-13
Figure 6-16	IP Address Details Window .....	6-14
Figure 6-17	Entering the Lantronix Interface .....	6-14
Figure 6-18	Lantronix XPort® Interface .....	6-15
Figure 6-19	Assigning IP Settings.....	6-16
Figure 6-20	HyperTerminal Connection.....	6-18
Figure 6-21	Connection Description Window .....	6-18
Figure 6-22	New Connection Dialog Box .....	6-19
Figure 6-23	Main Terminal Window.....	6-20
Figure 6-24	ENET Properties Window .....	6-20
Figure 6-25	XTR-ENET Properties Dialog Box .....	6-21
Figure 6-26	ASCII Setup Dialog Box .....	6-22
Figure 6-27	Main HyperTerminal Window .....	6-23
Figure 6-28	Saving Session.....	6-23
Figure 6-29	Saved Session.....	6-24

Figure 6-30	Multiple Power Supplies and Two Computers.....	6-25
Figure 6-31	HyperTerminal Session.....	6-26
Figure 6-32	System with Two Connected Devices .....	6-27
Figure 6-33	ENET and RS-485 Bus.....	6-28
Figure 6-34	HyperTerminal Window .....	6-28
Figure 1-35	PC on Same Side of Router as Power Supply.....	6-55
Figure 1-36	Home Page.....	6-56
Figure 1-17	AMETEK LXI Discovery Browser.....	6-57
Figure 1-38	Power Supply Hidden Behind a Router.....	6-58
Figure 1-39	Router Home Page .....	6-59
Figure 1-40	Port Forwarding .....	6-60
Figure 7-1	Offset (Intercept) Error and Gain (Slope) Error .....	7-3
Figure 7-2	Calibration: Step 1 Gain Calibration .....	7-4
Figure 7-3	Calibration: Step 2 Offset Calibration .....	7-4
Figure 7-4	Calibration: Step 3 Recalibrate Gain .....	7-5
Figure C-1	XG/XTR 850 Watt Mechanical Dimensions: 6 to 40 V Models.....	C-13
Figure C-2	XG/XTR 850 Watt Mechanical Dimensions: 60 V to 600 V Models .....	C-14
Figure C-3	XG/XTR 1700 Watt Mechanical Dimensions: 6 V to 40 V Models .....	C-15
Figure C-4	XG/XTR 1700 Watt Mechanical Dimensions: 6 V to 40 V Models DC Output Cover.....	C-16
Figure C-5	XG/XTR 1700 Watt Mechanical Dimensions: 60 V to 600 V Models .....	C-7
Figure C-6	XG/XTR 1700 Watt Mechanical Dimensions: 60 V to 600 V Models w/DC Output Cover.....	C-18
Figure D-1	Single (left,) and Dual (right) Half Rack Mount Kit Options .....	D-2
Figure D-2	Full Rack Mount Kit Option .....	D-3
Figure A-3	RM-XG2/RM-XTR2 Rack Rails.....	D-5
Figure A-4	Finding Rack Depth.....	D-6
Figure A-5	Selecting a Rail Type.....	D-7
Figure D-6	Modifying Rear Bracket .....	D-8
Figure A-7	Removing Chassis Member From Slides.....	D-8
Figure D-8	Attaching Front And Rear Bracket To Cabinet Section.....	D-9
Figure D-9	Mounting Cabinet Section Into Rack.....	D-10
Figure D-10	Installing Chassis.....	D-11

## Tables

Table 1-1	XG/XTR 850 Watt Series Voltage and Current Ranges.....	1-3
-----------	--	-----

## Contents

---

Table 1-2	XG/XTR 1500 Watt Series Voltage and Current Ranges .....	1-3
Table 1-3	XG/XTR 1700 Watt Series Voltage and Current Ranges .....	1-4
Table 2-1	Basic Setup Procedure .....	2-2
Table 2-2	XG/XTR 1500 and 1700 Watt: Recommended AC Input Wire (higher power).....	2-6
Table 2-3	Current Carrying Capacity for Load Wiring .....	2-8
Table 3-1	Select and Set from the Front Panel .....	3-3
Table 3-2	Front Panel Display Text .....	3-9
Table 3-3	Shipped Configuration.....	3-16
Table 3-4	Alarm Order of Precedence.....	3-19
Table 3-5	Alarm Mask Bit Positions .....	3-22
Table 3-6	Alarm Latch Bit Positions.....	3-23
Table 3-7	Power Cycle Saved/Recalled Settings .....	3-36
Table 3-8	User Accessible Saved/Recalled Settings Voltage Setpoint .....	3-37
Table 3-9	Power Supply Default Settings.....	3-40
Table 4-1	Monitor Lines .....	4-3
Table 4-2	Remote Programming Options .....	4-4
Table 4-3	APG Pins and Functions J1 .....	4-5
Table 4-4	AUX Output and ISOL Connector Pins and Functions J3.....	4-21
Table 5-1	Remote Control Connector Pins and Functions J4 and J61 .....	5-3
Table 5-2	DB-9 Pinouts .....	5-4
Table 5-3	RJ-45 Pinouts .....	5-4
Table 5-4	DB-25 Pinouts .....	5-5
Table 5-5	DB-9 Pinouts .....	5-7
Table 5-6	RJ-45 Plug Pinouts .....	5-7
Table 5-7	RJ-45 Plug on Slave Unit.....	5-8
Table 5-8	Rules for Multichannel Responses .....	5-27
Table 5-9	Status Byte Summary Register.....	5-32
Table 5-10	Standard Event Status Register .....	5-36
Table 5-11	OPERation Status Register .....	5-40
Table 5-12	OPERation SHUTdown Status Register .....	5-41
Table 5-13	OPERation SHUTdown PROTection Status Register .....	5-41
Table 5-14	OPERation CSHare Status Register .....	5-42
Table 5-15	QUESTionable Status Register .....	5-49
Table 5-16	QUESTionable VOLTage Status Register .....	5-50
Table 5-17	QUESTionable TEMPerature Status Register.....	5-50
Table 5-18	Preset Values of User Configurable Registers .....	5-58
Table 5-19	Alarms Bit Mask .....	5-73
Table 7-1	Troubleshooting.....	7-28

---

Table A-1	IEEE 488.2 Commands.....	A-14
Table A-2	Readback Commands .....	A-16
Table A-3	SCPI Commands for Output Control.....	A-17
Table A-4	SCPI Commands for Calibration.....	A-18
Table A-5	SCPI Commands to Clear All Protection Mechanisms .....	A-21
Table A-6	SCPI Commands for Foldback Protection .....	A-22
Table A-7	SCPI Commands for Power .....	A-23
Table A-8	SCPI Commands for Triggering.....	A-23
Table A-9	System Commands .....	A-24
Table A -10	Status Commands .....	A-27
Table A-11	Protection Commands.....	A-35
Table A-12	Auto Sequence Commands .....	A-35
Table B-1	Command Error List.....	B-3
Table B-2	Execution Error List .....	B-4
Table B-3	Device-Specific Error List .....	B-5
Table B-4	Query Error List .....	B-6
Table C-1	XG/XTR 850 Watt Electrical Specifications for 6 V to 600 V Models.....	C-2
Table C-2	XG/XTR 1500 Watt Electrical Specifications for 6 V to 600 V Models.....	C-4
Table C-3	XG 1700 Watt Electrical Specifications for 6 V to 600 V Models .....	C-6
Table C-4	Remote Operation.....	C-8



# 1

## Introduction

Chapter 1, Introduction, describes the features of the XG/XTR Family Programmable DC Power Supply.

## Features and Options

The XG /XTR Family Programmable DC Power Supply provides stable, variable output voltage and current for a broad range of development and system requirements. The power supplies have a high power density and numerous industry standard interfaces:

- RS-232, RS-485, analog programming (APG) and USB built-in ports.
- Optional GPIB or Ethernet (ENET), isolated analog programming (ISOL), control for remote operation and readback.
- Seamless switching between front panel and any digital interface (RS-232, RS-485, USB, GPIB or ENET).
- Simultaneous digital displays for both voltage and current.
- Front panel control by rotary Adjust/Enter knob, permitting high resolution output setting.
- Active Power Factor Correction (PFC) reduces input current and input current harmonics.
- Automatic crossover system allowing the power supply to switch between Constant Current and Constant Voltage operating modes.
- Parallel or series connection among multiple units to produce greater diversity or to use in higher power applications.
- Short-circuit protection of DC outputs providing greater operating safety.
- Built-in APG and ISOL (optional) interface to provide a galvanically isolated analog voltage control of the output, master/slave output tracking, and remote Enable/disable for safety and precision.
- Remote output voltage sensing to automatically compensate for cable losses.
- Software calibrated.
- Three user setting memory locations.
- M10 Option preprograms the voltage to reset to zero upon power on and upon output enable.



## XG and XTR Models (firmware version 2.0 and higher)

Table 1-1 lists the models in the XG/XTR 850 Watt series covered by this Manual.

**Table 1-1 XG/XTR 850 Watt Series Voltage and Current Ranges**

Model	Output Voltage	Output Current
6-110	0-6 V	0-110 A
8-100	0-8 V	0-100 A
12-70	0-12 V	0-70 A
20-42	0-20 V	0-2 A
33-25	0-33 V	0-25 A
40-21	0-40 V	0-21 A
60-14	0-60 V	0-14 A
80-10.5	0-80 V	0-10.5 A
100-8.5	0-100 V	0-8.5 A
150-5.6	0-150 V	0-5.6 A
300-2.8	0-300 V	0-2.8 A
600-1.4	0-600 V	0-1.4 A

Table 1-2 lists the models in the XG/XTR 1500 Watt series covered by this Manual.

**Table 1-2 XG/XTR 1500 Watt Series Voltage and Current Ranges**

Model	Output Voltage	Output Current
6-220	0-6 V	0-220 A
8-187.5	0-8 V	0-187.5 A
12.5-120	0-12.5 V	0-120 A
20-76	0-20 V	0-76 A
30-50	0-30 V	0-50 A
40-38	0-40 V	0-38 A
60-25	0-60 V	0-25 A
80-19	0-80 V	0-19A
100-15	0-100 V	0-15 A
150-10	0-150 V	0-10 A
300-5	0-300 V	0-5 A
600-2.6	0-600 V	0-2.6 A

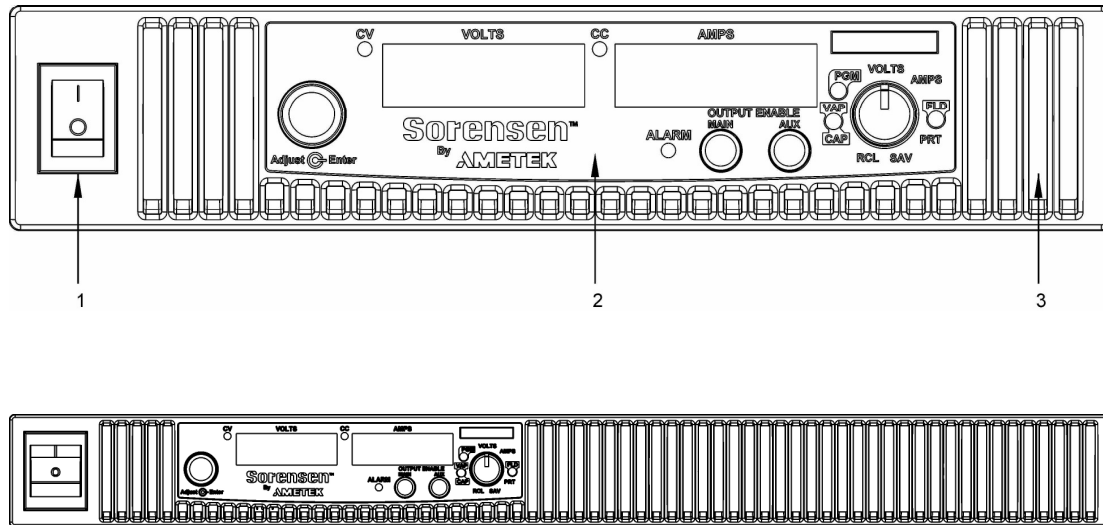
Table 1-2 lists the models in the XG/XTR 1700 Watt series covered by this Manual.

**Table 1-2 XG/XTR 1700 Watt Series Voltage and Current Ranges**

<b>Model</b>	<b>Output Voltage</b>	<b>Output Current</b>
6-220	0-6 V	0-220 A
8-200	0-8 V	0-200 A
12-140	0-12 V	0-140 A
20-84	0-20 V	0-84 A
33-50	0-33 V	0-50 A
40-42	0-40 V	0-42 A
60-28	0-60 V	0-28 A
80-21	0-80 V	0-21 A
100-17	0-100 V	0-17 A
150-11.2	0-150 V	0-11.2 A
300-5.6	0-300 V	0-5.6 A
600-2.8	0-600 V	0-2.8 A

## Front Panel

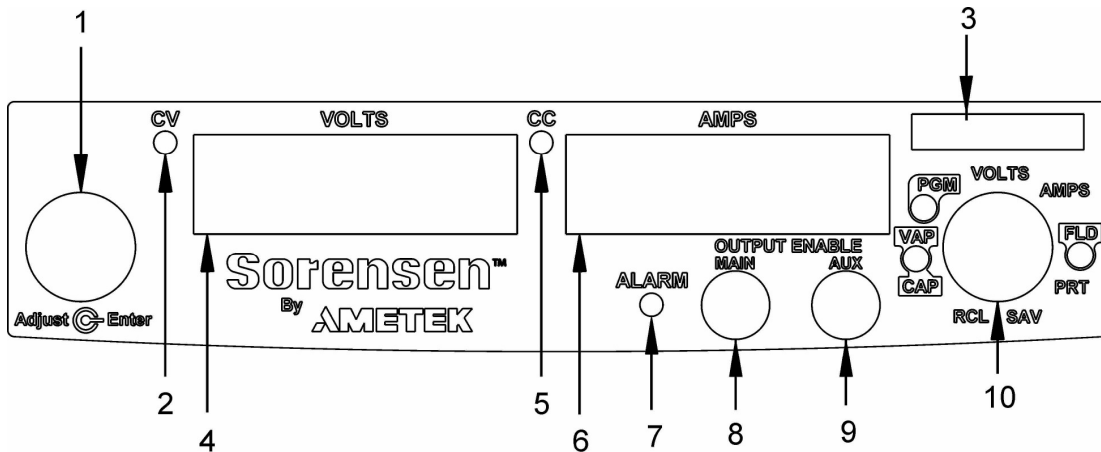
1



**Figure 1-1** XG/XTR Front Panels (Half Rack, above; Full Rack, below; not to-scale)

Item	Description
1	Front panel power switch
2	Front panel display. See Figure 1-2 for details.
3	Air Intake Vents

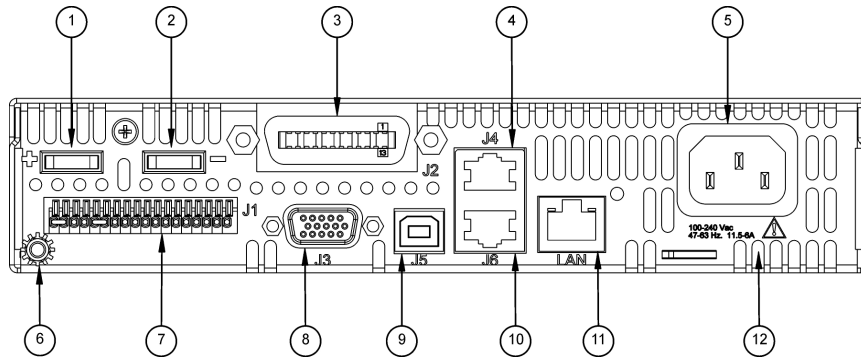
## Front Panel Display and Controls



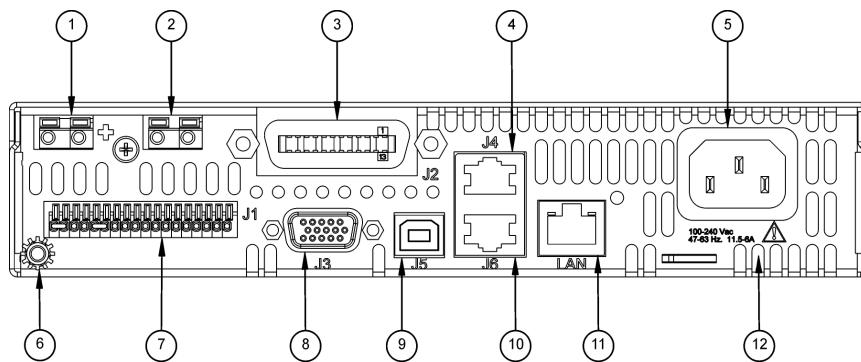
**Figure 1-2** Front Panel Display and Controls

Item	Description
1	Rotary Adjust/Enter control
2	Constant Voltage (CV) Mode LED (green)
3	Model Identification Label
4	Output Voltage Display
5	Constant Current (CC) Mode LED (green)
6	Output Current Display
7	Alarm Indicator LED (red)
8	OUTPUT ENABLE Main button
9	OUTPUT ENABLE Aux button
10	9-Position Mode Control (For detailed information, see "Configuring Settings from the Front Panel" on page 3-2).

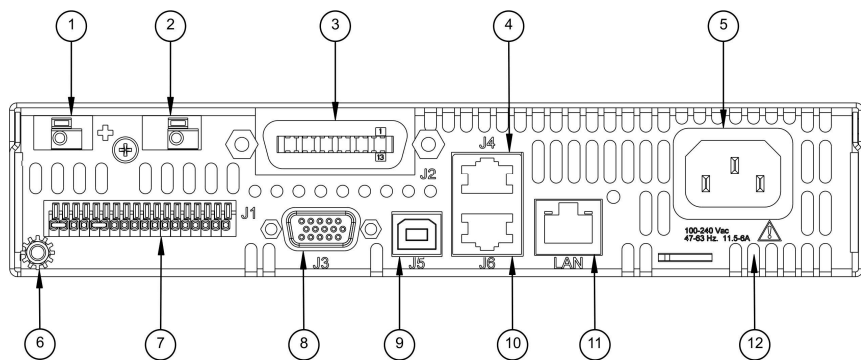
## Rear Panel Connectors on 850 Watt Models



**Figure 1-3** XG/XTR 850 Watt Units: 6 V to 40 V Models



**Figure 1-4** XG/XTR 850 Watt Units: 60 V to 150 V Models

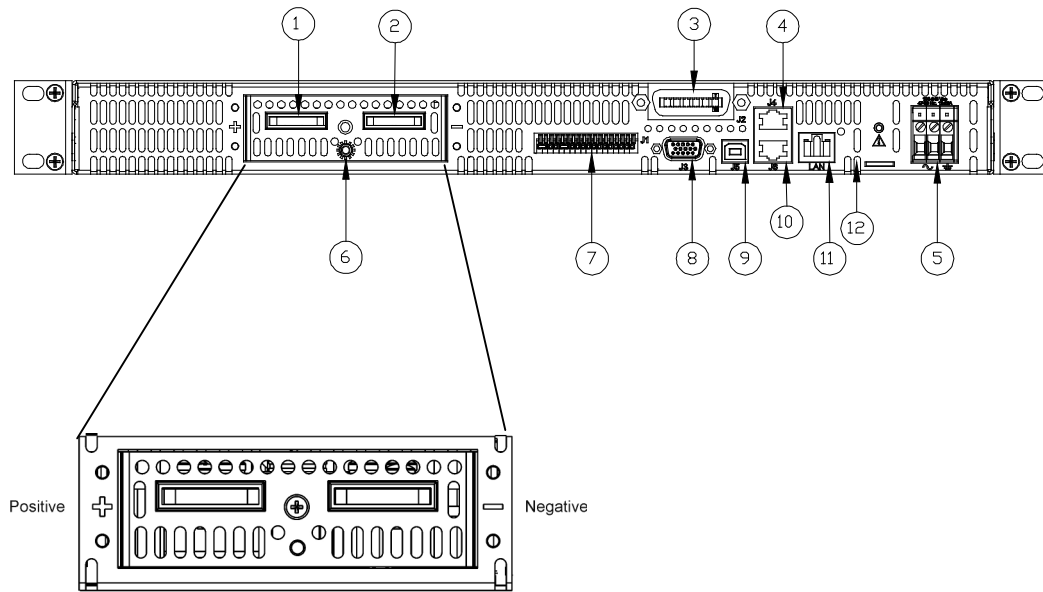


**Figure 1-5** XG/XTR 850 Watt Units: 300 V to 600 V Models

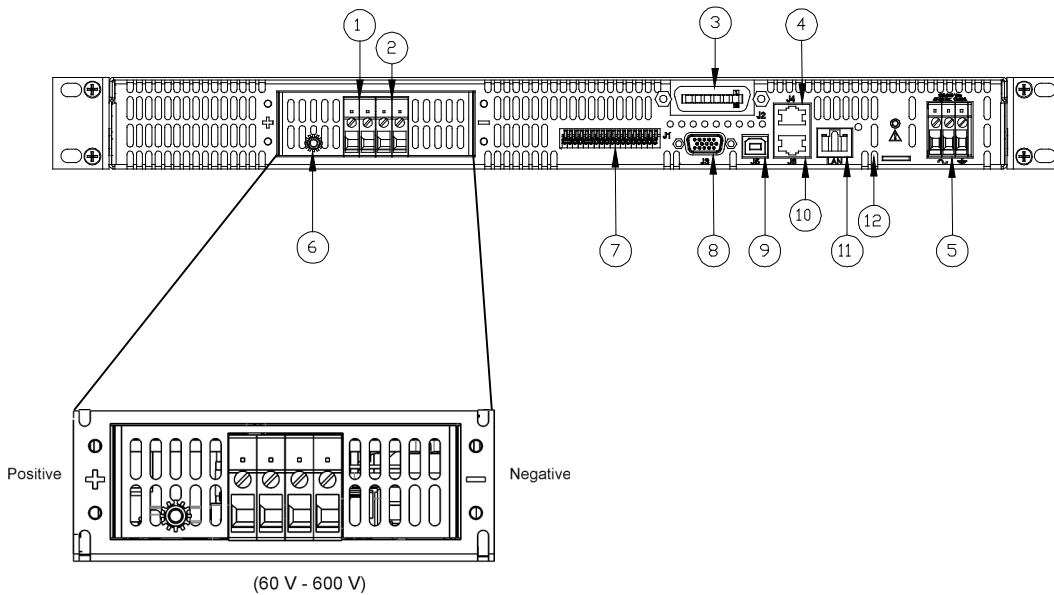
<b>Item</b>	<b>Description</b>
1	6 V– 40 V Models: DC Output Terminal Positive 60 V–150 V Models: DC Output Connectors Positive (6.5 mm hole diameter) 300 V–600 V Models: DC Output Connectors Positive (6.5 mm hole diameter)
2	6 V– 40 V Models: DC Output Terminal Negative 60 V–150 V Models: DC Output Connectors Negative (6.5 mm hole diameter) 300 V–600 V Models: DC Output Connectors Negative (6.5 mm hole diameter)
3 (J2)	Ethernet (ENET) or GPIB Connector (optional)
4 (J4)	RS-232/RS-485 Connector In Port
5	AC Input Connector (IEC Type)
6	Chassis Ground Stud
7 (J1)	Analog Programming (APG) Connector. For pin information, see page 4-5.
8 (J3)	AUX Output and Isolated Analog Programming (ISOL) Connector. For pin information, see page 4-20.
9 (J5)	USB Connector
10 (J6)	RS-485 Connector Multichannel Port
11	Ethernet/LAN (option) Connector
12	Fan Exhaust Vents

# Rear Panel Connectors on 1500 and 1700 Watt Models

1



(6 V - 40 V)  
**Figure 1-6 XG/XTR 1500 and 1700 Watt Units: 6 V to 40 V Models**



(60 V - 600 V)  
**Figure 1-7 XG/XTR 1500 and 1700 Watt Units: 60 V to 600 V Models**

Item	Description
1	6 V– 40 V Models: DC Output Terminal Positive (8.5 mm hole diameter) 60 V–600 V Models: DC Output Connectors Positive
2	6 V– 40 V Models: DC Output Terminal Negative (8.5 mm hole diameter) 60 V–600 V Models: DC Output Connectors Negative
3 (J2)	Ethernet (ENET) or GPIB Connector (optional)
4 (J4)	RS-232/RS-485 Connector In Port
5	AC Input Terminal
6	Chassis Ground Stud
7 (J1)	Analog Programming (APG) Connector. For pin information, see page 4–5.
8 (J3)	AUX Output and Isolated Analog Programming (ISOL) Connector. For pin information, see page 4–20.
9 (J5)	USB Connector
10 (J6)	RS-485 Connector Multichannel Port
11	Ethernet Connector
12	Fan Exhaust Vents



# 2

## Installation

Chapter 2, Installation, provides information and procedures for inspecting, installing, and testing the power supply.

## Basic Setup Procedure

Table 2-1 provides a summary of the basic setup procedure with references to the relevant sections in this chapter. Refer to this table if you are unfamiliar with the installation requirements for the power supply. Complete each step in the sequence given.

**Table 2-1** Basic Setup Procedure

Step	Description	Action	Reference
1	Inspect	Inspect the power supply.	“Step 1: Inspecting and Cleaning” on page 2-3.
2	Install	Install the power supply (benchtop or rack mount). Ensure adequate ventilation.	“Step 2: Location and Mounting” on page 2-4.
3	Connect Input Power	Connect AC input power.	“Step 3: Connecting AC Input Power” on page 2-5.
4	Select Wires	Select wires that are correctly rated for the maximum DC output current.	“Step 4: Selecting Load Wires” on page 2-8.
5	Te s t	Perform functional tests for voltage mode operation, current mode operation, and front panel controls.	“Step 5: Performing Functional Tests” on page 2-10.
6	Connect Loads	Connect the load wires to the DC output.	“Step 6: Connecting Loads” on page 2-12.
7	Connect Remote Sensing (if required)	Connect remote sensing connectors on power supply to load.	“Step 7: Connecting Remote Sensing” on page 2-15.

---

## Step 1: Inspecting and Cleaning

### Initial Inspection

**When you first receive your unit, perform a physical check:**

1. Inspect the unit for any scratches and cracks, broken switches, connectors or displays.
2. Ensure that the packing box contains the 7.5 foot (2.5 m) power cord (supplied with the XG/XTR 850 W model only).
3. If you see external damage or suspect internal damage, contact the carrier immediately.

2

### Periodic Cleaning

The power supply only requires periodic cleaning, not routine servicing. Whenever a unit is removed from operation, clean the metal surfaces with naphtha or an equivalent solvent, and clean the front panel with a weak solution of soap and water. Use low-pressure compressed air to blow dust from components on the printed circuit boards.

## Step 2: Location and Mounting

The power supply may be rack-mounted or used in benchtop applications.

### Rack Mounting

The XG/XTR 850 Watt power supply is designed to fill half of a standard 19 inch (483 mm) equipment rack. The XG/XTR 1500 and 1700 Watt power supplies are designed to fill a standard 19 inch (483 mm) equipment rack.

Units can be combined with the same models in the 850 W or 1500 and 1700 W series for customer applications.

### Purchasing Rack Mount Kits

Contact Customer Service (see “Contact Information” on page i) about purchasing the Rack Mount Kit options. For a list of the part numbers, see Appendix D Rack Mount Kit Options. Installation information for the different rack mount options are provided with the rack mount kits.

For product support, visit [www.programmablepower.com](http://www.programmablepower.com) and navigate to the DC Power Supplies page.

### Ventilation

Whether operating the power supply in a rack or on a bench, allow air to reach the ventilation inlets on the front and rear of the unit for cooling. The direction of airflow is from the front of the unit to the back of the unit. Ventilation space is not required at the top, bottom or sides of the power supply.

---

## Step 3: Connecting AC Input Power

---

**WARNING: Shock hazard**

Disconnect AC power from the unit before removing the cover. Even with the front panel power switch in the Off position, live line voltages are exposed when the cover is removed. Repairs must be made by an Authorized Service Center.

---

**WARNING: Shock hazard**

There is a potential shock hazard if the power supply chassis and cover are not connected to an electrical ground via the safety ground in the AC input connector. Ensure that the power supply is connected to a grounded AC outlet with the recommended AC input cord configured for the available line voltage as described in this section.

---

**WARNING: Shock hazard**

The AC input cord is the disconnect device for the power supply. The plug must be a non-locking plug which is readily identifiable by and accessible to the operator. The input cord must be no longer than 9.84 feet (3 m).

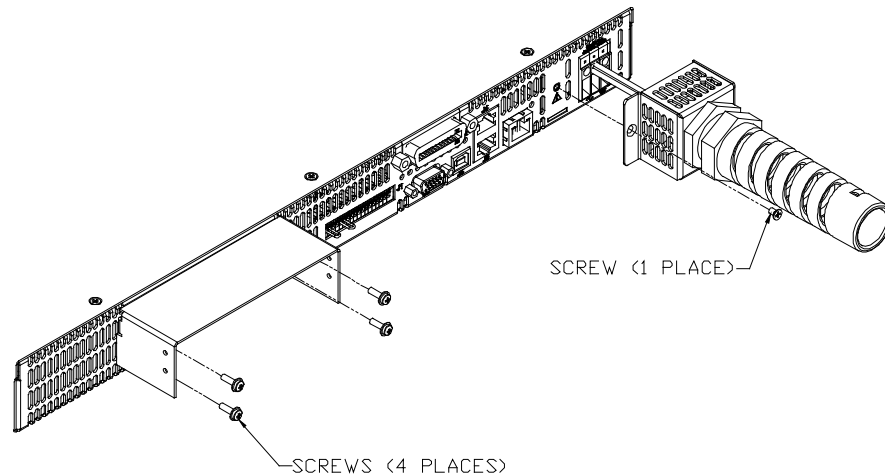
---

### XG/XTR 850 Watt AC Input Connector

On the 850 Watt models, the AC input connector is a standard IEC 16 A 250 V male connector located on the rear panel of the power supply. The AC input cord provided is rated for 30 A, 300 V and appropriate for use in any country.

## XG/XTR 1500 and 1700 Watt AC Input Connector

On the XG/XTR family 1U, full 19-inch rack models, the AC input connector is a 3-terminal wire clamp located on the rear panel of the power supply.



**Figure 2-1 1500 and 1700 Watt AC Input Cover and Strain Relief**

## XG/XTR 1500 and 1700 Watt AC Input Wire

The full 19-inch rack models are not supplied with a power cord or a non-locking AC plug. Table 2-2 specifies the recommended AC input wire size. You must also purchase and install the correctly rated non-locking plug for your installation.

Make sure that the wiring of the product and the AC plug comply with the applicable local code for your installation. If you require a special cord, contact Customer Service (see “Contact Information” on page i).

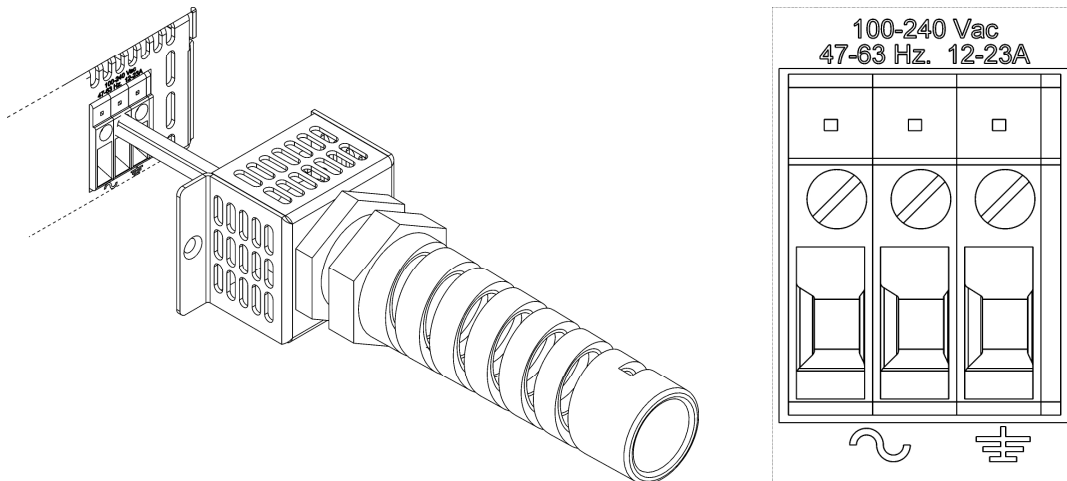
**Table 2-2 XG/XTR 1500 and 1700 Watt: Recommended AC Input Wire (higher power)**

AC Input Voltage Range and Frequency	Wire Specifications
85-265 Vac, 47-63 Hz, single phase 3 wire	3 x 10 AWG (2 wire plus safety ground, stranded copper, 60 °C minimum, 300 V. The input cord must be no longer than 9.84 feet (3 m).

## XG/XTR 1500 and 1700 Watt AC Input Wire Connection

### To make the AC input wire connections:

1. Strip the outside insulation on the AC cable approximately 4 in. (100 mm). Trim the wires so that the ground wire is 0.5 in. (12 mm) longer than the other wires. Strip 0.55 in. (14 mm) at the end of each of the wires.
2. Unscrew the base of the strain relief from the helix-shaped body. Insert the base through the outside opening in the AC input cover and, from the inside, screw the locknut securely onto the base.
3. Slide the helix-shaped body onto the AC cable. Insert the stripped wires through the strain relief base until the outer cable jacket is flush with the edge of the base. Tighten the body to the base while holding the cable in place. The cable is now securely fastened inside the strain relief.
4. Route the AC wires to the input connector terminals as required. For AC input terminal locations, see lower inset in Figure 2-1. To connect the wiring, loosen the terminal screw, insert the stripped wire into the terminal, and tighten the screw securely.
5. Route the wires inside the cover to prevent pinching. Fasten the AC cover (shown below) in kit provided to the unit using the screw provided. See Figure 2-1.



## Step 4: Selecting Load Wires

This section provides recommendations for selecting minimum load wire sizes.

### Load Wiring

To select the wiring for connecting the load to the power supply, consider the following factors:

- Insulation rating of the wire. Current carrying capacity of the wire.
- Maximum load wiring length for operation with remote sense lines.
- Electrical noise and impedance effects of the load lines.

### Insulation Rating

Use load wiring with a minimum insulation rating equivalent to the maximum output voltage of the power supply.

### Current Carrying Capacity

The load wiring must have a current carrying capacity greater than the output rating of the power supply to ensure that the load wiring will not be damaged if the load is shorted. Table 2-2 shows the maximum current rating for various gauges of wire rated for 105 °C operation, based on a maximum current density of 450 A/cm<sup>2</sup>.

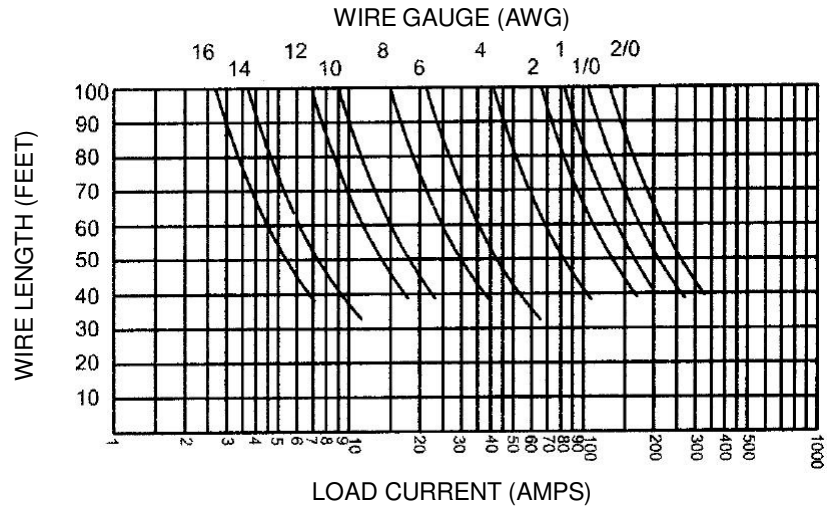
Operating at the maximum current rating shown in Table 2-2 results in an approximately 30 °C temperature rise for an appropriately-sized load wire operating in free air. Where load wiring must operate in areas with elevated ambient temperatures or bundles with other wiring, use larger gauges or wiring rated for higher temperatures.

**Table 2-3** Current Carrying Capacity for Load Wiring

Wire Size (AWG)	Maximum Current (Amps)	Wire Size (AWG)	Maximum Current (Amps)
20	2.5	6	61
18	4	4	97
16	6	2	155
14	10	1	192
12	16	1/0	247
10	21	2/0	303
8	36		



## Maximum Load Wiring Length For Operation With Sense Lines



2

Figure 2-2 Maximum Load Wire Length for 1 V Line Drop

## Noise and Impedance Effects

To minimize noise pickup or radiation, use shielded twisted pair wiring of the shortest possible length for load sense wires. Connect the shield to the power supply chassis. Where shielding is impossible or impractical, simply twisting the wires together will offer some noise immunity.

## Step 5: Performing Functional Tests

The functional test procedures include:

- Power-on and front panel functional checks
- Voltage mode operation and current mode operation checks.

For information on local operation, see “Local Operation” on page 3-1 for adjusting front panel controls and settings.

### Powering the Power Supply On/Off

#### To power on the power supply:

1. Ensure that the front panel power switch is in the Off position.
2. Ensure that the AC line voltage is within operating range.
3. Connect the line cord to a grounded AC outlet.
4. Turn the front panel power switch to the On position.

After a short power-on delay, **8888 8888** illuminates on the output voltage and current displays, followed by **PSU On**.

After approximately 1 second, the display returns to normal status.

#### To power off the power supply:

- ◆ Turn the front panel power switch to the Off position.

**AC FAIL** will blink on the display. The ALARM LED illuminates. After a short delay, all lights on the display will not be illuminated.

## Voltage and Current Mode Operation Checks

### To perform the voltage and current mode operation checks:

1. Ensure that the front panel power switch is in the On position and the output is disconnected.
2. If the OUTPUT ENABLE Main button is illuminated, press the button to turn off the output.
3. To check voltage mode operation, turn the 9-position mode control to the VOLTS position.

The voltage set point will blink dimming and then return to full brightness. For more information, see “Local Operation” on page 3-1.

4. Adjust the voltage to 5 V.
5. To check current mode operation, turn the 9-position mode control to AMPS position.  
Verify that the current set point is blinking in the output current display.
6. Adjust the current to 1 A.
7. Press the OUTPUT ENABLE Main button to turn On.
8. Turn the front panel power switch to the Off position.
9. Turn the front panel power switch to the On position.
10. Connect a short circuit across the output terminals. Use leads of sufficient current carrying capacity. (See “Step 4: Selecting Load Wires”.)
11. Press the OUTPUT ENABLE Main button to enable the output. The button will be illuminated when the output is enabled.

CC Mode LED illuminates and the voltage and current are displayed. CC Mode LED illuminates and the preset load current is displayed.

12. Turn the front panel power switch to the Off position.

## Step 6: Connecting Loads

This section describes how to connect loads to the power supply for both single and multiple loads.



### **WARNING: Shock hazard**

There is a shock hazard at the power supply output when operating at an output greater than 40 V. To protect personnel against accidental contact with hazardous voltages, ensure that the load and its connections have no accessible live parts.



### **CAUTION: Cable damage**

When making connections to the output terminals, ensure terminals of opposite polarity do not touch. Load cables and sense wires should be provided with strain relief.

## DC Output Connectors



### **WARNING: Shock hazard**

Disconnect the AC input before making any connections. A shock hazard may be present at the output terminals. Allow 15 seconds after the AC power has been removed before making any connections.

### 6 V-40 V Models

The 6 V-40 V models are equipped with output terminals, as shown in Figures 1-3 and 1-6.

### 60 V-150 V Models

The 60 V-150 V models are equipped with output connectors, as shown in Figures 1-4, 1-5 and 1-7. These models have output currents that may require users to use wire diameters that would not fit into a single output connector, so there are two output connectors in parallel to increase the potential current carrying capacity of load wiring.

### 300 V-600 V Models

The 300 V-600 V models are equipped with output connectors, as shown in Figure 1-5.

## Inductive Loads and Batteries



### CAUTION

The XG/XTR power supply requires freewheeling and blocking diodes across the output while driving inductive loads or batteries to protect the power supply from damage caused by power being fed back into the supply and from high voltage transients.

2

### Selecting Diodes

The diode must have a voltage rating at least 20% greater than the power supply's output voltage and have a current rating greater than or equal to the power supply's output rating. Connect the cathode to the positive output and the anode to the return.

Where positive load transients such as back EMF from a motor may occur, connect a Transient Voltage Suppressor (TVS) or a varistor across the output to protect the power supply. The breakdown voltage rating for the TVS or varistor must be approximately 10% higher than the rated supply output.

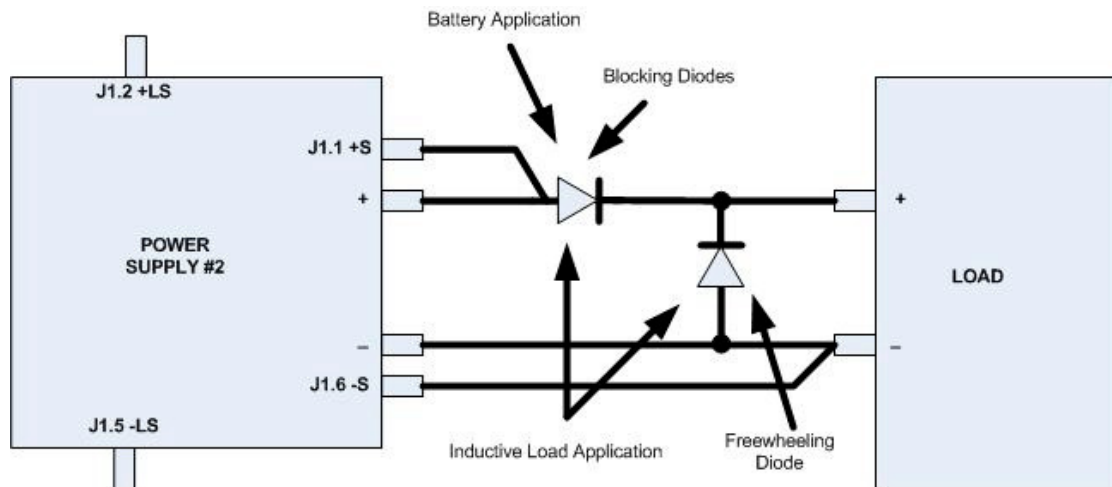


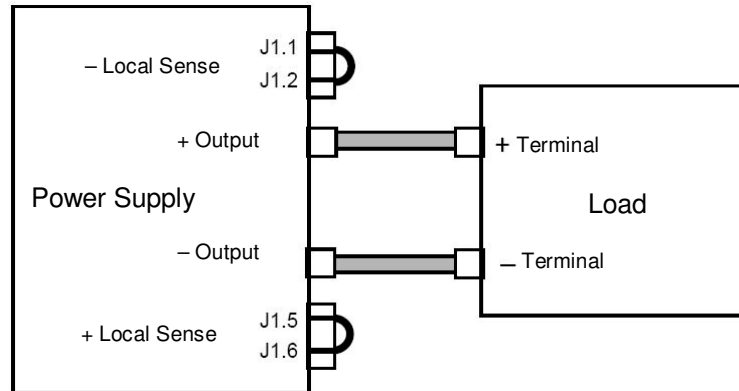
Figure 2-3 Diode Placement

For a detailed Application Note, please go to: [www.programmablepower.com](http://www.programmablepower.com) and click SUPPORT.

## Connecting Single Loads

Figure 2-3 shows the recommended load connections for a single load which is sensing its voltage locally. Local sense lines shown are the default connections at the rear panel APG J1 connector (see Figure 4-1 on page 4-5). The load lines should use the largest gauge and shortest length of wire possible to ensure optimal performance.

You do not need remote sensing for basic operation of your power supply. However, if you wish to correct any small drops in your load lines, then use the remote sensing feature. See “Step 7: Connecting Remote Sensing” on page 2-15 for more information.



**Figure 2-4** Connecting Single Loads

## Connecting Multiple Loads

The proper connection of distributed loads is an important aspect of power supply use. The common method of connection is a radial load connection. Power is connected to each load individually from a single pair of terminals designated as the positive and negative distribution terminals. This pair of terminals may be the power supply output terminals, the load terminals, or a distinct set of terminals especially established for distribution use. In this scheme, there are no ground loops and the effect of one load upon another is minimized.

## Step 7: Connecting Remote Sensing



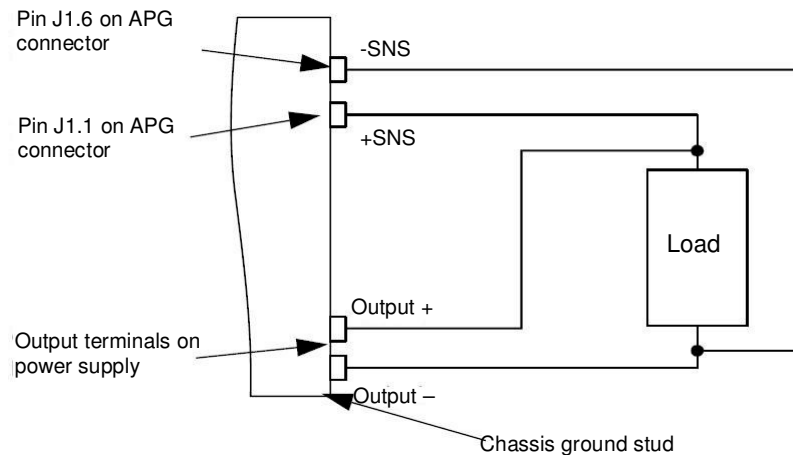
### WARNING: Shock hazard

There is a potential shock hazard at the sense connectors when using a power supply at an output greater than 40 V. Select wiring with a minimum insulation rating equivalent to the maximum output voltage of the power supply for use as local sense jumpers or for remote sense wires. Ensure that connections at the load end are shielded to prevent contact with hazardous voltages.

2

Remote sensing permits you to shift the regulation point of the power supply from the output terminals to the load or other distribution terminals.

Use shielded twisted pair wiring of 20 to 26 AWG for best noise performance. Make sure that the shielded twisted pair wiring insulation is rated higher than the maximum output voltage of the power supply. If possible, one end of the shield of the sense lines should be attached to the chassis ground of the power supply.



**Figure 2-5** Remote Sense Connection

#### To connect the remote sense wires:

1. Ensure that the front panel power switch is in the Off position.
2. Using a small flat blade screwdriver, remove the two sense jumpers from pins J1.1 and J1.2, and from pins J1.5 and J1.6 on the APG Connector. See Figure 4-1, “APG Connector Terminals” on page 4-5.

3. Connect one end of the shield of the twisted pair wire to the chassis ground point on the power supply.
4. Connect the positive sense line (+SNS) from the positive regulation point as close as possible to the load terminals to pin J1. 1.
5. Connect the negative sense line (-SNS) from the return of the load to pin J1-6.

To compensate for losses in power leads connected to the output, the power supply provides sense connections beside the output terminals. With remote sense leads in place, the power supply regulates to the displayed voltage at the point where the sense lines are connected to the output leads. With the sense lines disconnected, the power supply regulates the voltage at the output terminals.



**CAUTION: Equipment damage**

Do not operate the power supply with sense lines connected to the load without also connecting the load power leads to the output terminals.



**CAUTION: Reverse polarity**

Avoid reversing positive (+) and negative (-) sense connections. When using remote sense to compensate for load line losses, ensure that the positive sense line is connected to the positive load terminal and the negative sense line is connected to the negative load terminal. Do not reverse these connections or the power supply may be damaged.

---

**Important:** Long load leads with large capacitance at the load and remote sensing can cause voltage instability due to inductance of the load leads. Measures to reduce inductance and/or capacitance (raising resonant frequency) or using local sense can be beneficial in stabilizing the system.

---



# 3

## Local Operation

Chapter 3, Local Operation, provides the procedures for local (front panel) operation such as:

- Configuring settings.
- Operating in constant voltage mode and constant current mode.
- Using the protection features.
- Using multiple power supplies.

## Introduction

Once you have installed the power supply and connected both the AC input power and the load (covered in “Installation” on page 2-1), the power supply is ready for local operation. To turn the power supply on, see “Powering the Power Supply On/Off” on page 2-10.

## Configuring Settings from the Front Panel

### Using the 9-Position Mode Control

The 9-position mode control is used with the rotary Adjust/Enter control to configure settings in local operation. See Figure 1-2, “Front Panel Display and Controls” on page 1-6 for location of the front panel features.

Using the 9-position mode control, select one of nine modes: VOLTS, AMPS, FLD, PRT, SAV, RCL, CAP, and VAP. See Figure 3-1 and Table 3-1 for detailed information on the nine modes.

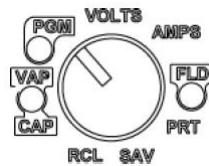


Figure 3-1 9-Position Mode Control

### Using the Rotary Adjust/Enter Control

The rotary Adjust/Enter control is used to change settings and set the value selected. The front panel displays information on the output voltage and output current displays. Each display has a maximum of four characters that are made up of 7 segments.

## Coarse and Fine Adjustment Modes

The coarse and fine adjustment modes are used for setting the voltage and current set points, OVP and UVP settings.

**Coarse adjustment mode** When using local operation to set the current and voltage set points, use the coarse adjustment mode (default) followed by the fine adjustment mode (see next). The coarse adjustment mode quickly adjusts the settings in large increments to reach the desired value.

**Fine adjustment mode** Pressing the rotary Adjust/Enter control to change the mode to fine adjustment mode, provides the ability to manipulate the last significant digit. Once the exact desired value for the setting has been selected, press the rotary Adjust/Enter control to commit the value to the unit.

**Table 3-1** Select and Set from the Front Panel

<b>9 Positions on the Mode Control Knob</b>	<b>Turning the rotary Adjust/Enter control lets you...</b>	<b>Pressing the rotary Adjust/Enter control lets you...</b>
VOLTS (Voltage Programming)	Select the voltage set point in coarse or fine adjustment modes. See “Automatic Mode Crossover” on page 3-13.	Set the value selected and cycle to the next setting.
AMPS (Current Programming)	Select the current set point in coarse or fine adjustment modes. See “Constant Current Mode Operation” on page 3-13.	Set the value selected and cycle to the next setting.
FLD (Foldback)	Select Foldback option: CC, CV or none. See “Setting Foldback Mode” on page 3-24.	Set the value selected and cycle to the next setting.
PRT (Protection)	Select the OVP set point (see page 3-27). Select the UVP set point (see page 3-29.) Select OTP temperature and Shutdown (see page 3-30.)	Set the value selected and cycle to the next setting.
SAV (Save User Preset)	Select the user setting memory location. See “Saving User Setting Memory Locations” on page 3-37.	Save user setting memory values.
RCL (Recall User Preset)	Select the user setting memory location. See “Recalling User Setting Memory Locations” on page 3-38.	Load user setting memory values into the power supply.

**Table 3-1** Select and Set from the Front Panel

<b>9 Positions on the Mode Control Knob</b>	<b>Turning the rotary Adjust/Enter control lets you...</b>	<b>Pressing the rotary Adjust/Enter control lets you...</b>
CAP (Current Analog Programming)	Select the programming source and select the range.	Set the value selected and cycle to the next setting.
VAP (Voltage Analog Programming)	Select the programming source and select the range.	Set the value selected and cycle to the next setting.
PGM (Programming Options)	Select the remote interface to be used for control, local lockout or current sharing.	Select interface/Option and cycle to the next setting.

---

## Navigating the Menu System

The menu system of the XG/XTR follows a select and set model with the exception of the VOLTS and AMPS modes. See “Setting VOLTS and AMPS Modes”.

**The general procedure for setting up the features in the select and set model is:**

1. To select a mode, rotate the 9-position Mode control to the desired mode or press the rotary Adjust/Enter control once to activate the current selection on the mode control knob. See Figure 3-3.
2. To select the feature or setting, rotate the rotary Adjust/Enter control to scroll through the different available settings of that mode.

The settings appear on the output current display.

3. Press the rotary Adjust/Enter control to select the feature or setting.
4. Set each value using the rotary Adjust/Enter control. When the value has been selected, press the rotary Adjust/Enter control to commit the updated value. Additional values may become available, depending on the setting that is being configured.

## Setting VOLTS and AMPS Modes

The only exceptions to the select and set model are the VOLTS and AMPS modes which do not allow the selection of tracking and select and set mode by turning the rotary Adjust/Enter control. In VOLTS and AMPS modes, the default entry mode setting is automatically selected as either voltage or current tracking, respectively.

Voltage and current values can be set in tracking mode or select and set mode using the rotary Adjust/Enter control:

- Tracking mode—the new values take effect as the rotary Adjust/Enter control is rotated.
- Select and set mode—the new values do not take effect until the rotary Adjust/Enter control is pressed. See “Normal Display Mode and Inactivity Timeout” on page 3-7.

**To access the tracking mode for entering voltage and current:**

1. Select the VOLTS or AMPS position on the 9-position mode control. If the set point is blinking, the unit is in coarse tracking mode.
  - When the VOLTS mode is selected, the voltage set point will blink in the output voltage display.
  - When the AMPS mode is selected, the current set point will blink in the output current display.
2. Use the rotary Adjust/Enter control to adjust the set point. Note that there is an activity time out (see Normal Display Mode and Inactivity Timeout on page 3-7).

The adjustments you make to the set point affect the opposing output value (voltage when in AMPS mode or current when in VOLTS mode), which will update in the non-blinking display.
3. Press the rotary Adjust/Enter control to enter fine adjust tracking mode.

The set point blinks faster when the unit is in fine adjust tracking mode.
4. Use the rotary Adjust/Enter control to fine tune the set point.
5. Once the set point has been selected, press the rotary Adjust/Enter control to exit tracking mode and return to normal display mode.

**To access the select and set entry mode for the voltage and current set points:**

1. Select VOLTS or AMPS position on the 9-position mode control.
2. Press the rotary Adjust/Enter control three times in succession to enter coarse Pre-Set Adjustment.
3. Press the rotary Adjust/Enter control one more time to enter fine Pre-Set Adjustment.
4. Press the rotary Adjust/Enter control once again to set the value.

The units can also timeout (adjustable) to exit the menu. Once Pre-Set Mode is entered,  $CSPC$  and  $FNPC$  will appear in the voltage display.

## Normal Display Mode and Inactivity Timeout

Normal display mode appears on the output voltage and current displays when the configuration changes from the front panel have been completed or when the inactivity timeout occurs (default is 3 seconds). Normal display mode shows the output voltage and current values.

If a timeout occurs before the changes made to the value have been set, the changes will not be saved and you will have to re-enter the changes. The inactivity timeout is variable from 1 to 20 seconds and can only be changed using the SCPI command.

**The SCPI command (s) for these instructions are:**

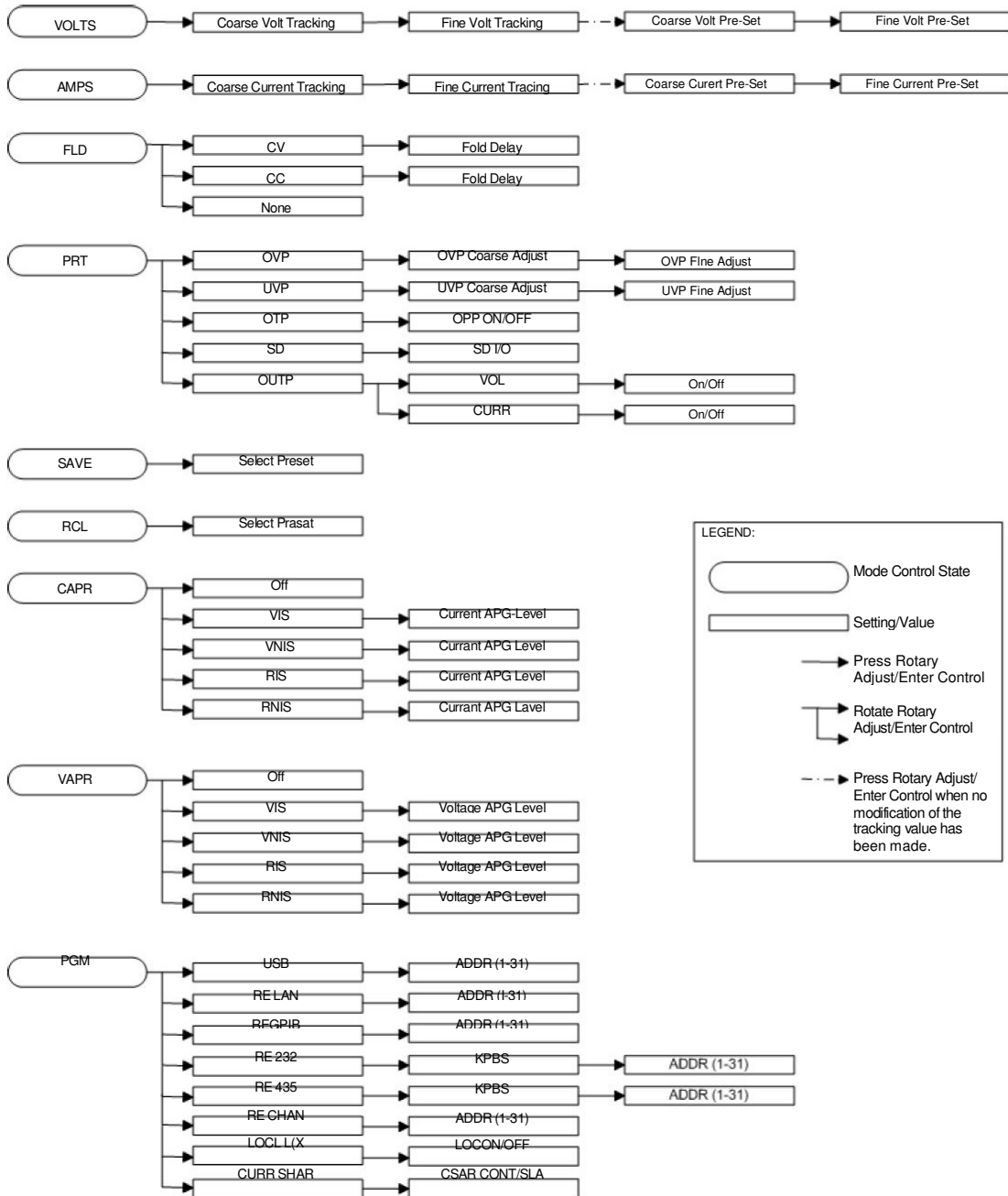
```
[:]SYSTem[<channel>]:FPANel[:TIMEout]
```

---

**Important:** Each user memory setting location stores the timeout so that beginning users and expert users are not required to use the same timeout

---

## Local Operation



**Figure 3-2** Front Panel Menu System



## Display Messages on the Front Panel

The front panel displays on the power supply will use text as shown in Table 3-2 to indicate the status or mode.

**Table 3-2** Front Panel Display Text

Display Text	Text Description
<i>0</i>	Negative Polarity
<i>232</i>	RS 232
<i>485</i>	RS 485
<i>8888</i>	All segments On, Power Up
<i>1</i>	Positive Polarity
<i>AC</i>	Alternating Current
<i>Addr</i>	RS 485 Address
<i>AnPr</i>	Analog Programming
<i>AS</i>	Power On Autostart
<i>AuAS</i>	Auxiliary Autostart
<i>[APr</i>	Current Analog Programming
<i>[CLr</i>	Clear
<i>[CC</i>	Constant Current
<i>[COn?</i>	Controller
<i>[CV</i>	Constant Voltage
<i>[CrPE</i>	Coarse Current Pre-set Mode
<i>[CrPU</i>	Coarse Voltage Pre-set Mode
<i>[Shr</i>	Current Share (same as CUrrShAr)
<i>[Urr</i>	Current
<i>[UrrShAr</i>	Current Share (same as CShr)
<i>dELA</i>	Fold Delay
<i>donE</i>	Done
<i>Err</i>	Error (debug)
<i>FOLd</i>	Foldback
<i>FAi L</i>	Fail
<i>FAn</i>	Fan
<i>FLA</i>	Flash
<i>FnPC</i>	Fine Current Preset Mode
<i>FnPU</i>	Fine Voltage Preset Mode
<i>Fld</i>	Foldback
<i>HbPS</i>	Data rate (kbps)
<i>GPi b</i>	GPiB Interface

Display Text	Text Description
<i>I n</i>	Interlock
<i>LAN</i>	ENET Interface
<i>LE C</i>	Current APG Level
<i>LE U</i>	Voltage APG Level
<i>Loc</i>	Lock
<i>LOCL</i>	Local
<i>OFF</i>	Off
<i>On</i>	On
<i>OUTP</i>	Output Protection
<i>OCP</i>	Over Current Protection
<i>OTP</i>	Over Temperature Protection
<i>OVP</i>	Over Voltage Protection
<i>UuPF</i>	Over Voltage Protection fine adjustment
<i>OUPC</i>	OVP Calibration
<i>POL</i>	Polarity
<i>Pr0</i>	Protection mode
<i>PSU</i>	Power Supply Unit
<i>r IS</i>	Isolated Resistive Analog Programming
<i>rCL</i>	Recall Preset
<i>rE</i>	Remote Programming/Interface
<i>rnl S</i>	Non-Isolated Resistive Analog Programming
<i>Con1</i>	Controller (current share controller)
<i>SHAr</i>	Share (current share)
<i>ChAn</i>	Multichannel Remote Interface
<i>S rS</i>	Soft reset
<i>SAUE</i>	Save Preset
<i>Sd</i>	Shutdown
<i>SLA</i>	Slave (current share slave)
<i>U IS</i>	Isolated Analog Voltage Programming
<i>Un IS</i>	Non-Isolated Analog Voltage Programming
<i>USb</i>	USB Interface
<i>UUP</i>	Under Voltage protection coarse adjustment
<i>UuPF</i>	Under Voltage protection fine adjustment
<i>UAPr</i>	Voltage Analog Programming
<i>UOL</i>	Voltage
<i>SLP</i>	Sleep Mode

A blinking numeric value is either a voltage or current set point in tracking mode. The display in which the set point appears, output voltage or output current display, indicates the type of set point, voltage or current.

## Standard Operation

The power supply can be controlled by two methods, either from the front panel or from any of the remote interfaces. Front panel control is referred to as local operation (default setting) while control via any of the remote interfaces is called remote operation. To set up the power supply for remote operation, see Chapter 5, “Remote Operation”. Once the remote connection has been established, the power supply can switch seamlessly between local operation and any digital interface (RS-232, RS-485, GPIB, USB and Ethernet).

Local lockout is a feature that allows the front panel to be locked so that accidental button presses are ignored. This feature is often used to lock out the front panel while a user is controlling the power supply from a remote location.

The output of the power supply has two modes of operation: Constant Voltage (CV) mode (see page 3-13) and Constant Current (CC) mode (see page 3-13). Both of the operating modes are available regardless of which control method (local or remote) is used.

## Operating Modes

The output mode in which the power supply operates at any given time depends on the following factors:

- Output voltage set point  $V_{SET}$

**Note: the M10 Option includes a preset function to automatically reset the output voltage to zero Volts at both power on and output enabled, unless deliberately programmed otherwise (see Output Protection, 3-333-33).**

- Output current set point  $I_{SET}$
- Impedance of the attached load  $R_L$

The two output modes of operation are Constant Voltage (CV) mode (see page 3-13) and Constant Current (CC) mode (see page 3-13).

### Output enabled

When the output is turned on, both the voltage and current rise as quickly as possible to try and reach the set points ( $V_{SET}$  and  $I_{SET}$ ) that were configured prior to enabling the output. Initially the unit will operate in CV mode, which is the default mode. As the voltage and current rise to meet the requirements of the load, the set point that is reached first (based on the  $R_L$ , either  $V_{SET}$  or  $I_{SET}$ ) will determine which mode the power supply will remain in. The operating mode is indicated by either the CC mode LED or the CV mode LED, one of which will illuminate on the front panel.

**Output disabled** The mode of operation is not determined until the output is enabled. The CV and CC mode LEDs will not indicate the mode while the output is disabled.

### Constant Voltage Mode Operation

If the output is enabled and the configured current set point is much higher than the requirements for the attached load, then the voltage will rise until it reaches the voltage set point. When the output voltage reaches the voltage set point, it stops rising. The unit will continue to operate in CV mode. The load current will still vary to meet any changes in required load current draw resulting from a change in the attached load.

### Constant Current Mode Operation

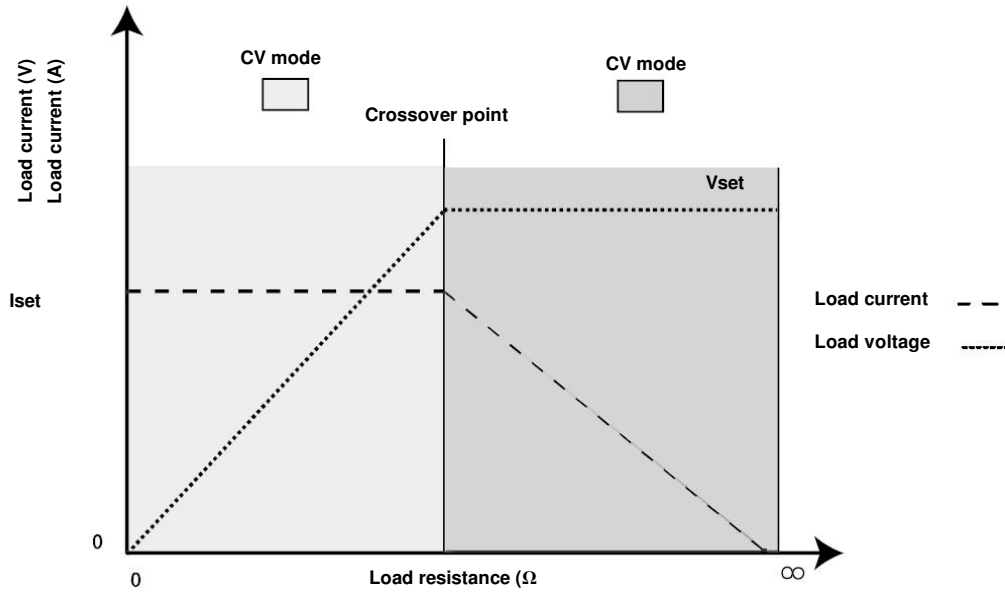
If the output is enabled, the voltage and current start to rise. At this time the unit is operating in CV mode (default operational mode). As the load current drawn reaches the value of the output current setting, the unit will switch to CC mode and not allow any additional current to be drawn above the value of  $I_{SET}$ . The unit is now operating in CC mode. The voltage will still vary to meet any changes in required output voltage resulting from a change in the attached load.

### Automatic Mode Crossover

Mode crossover occurs when the unit makes the switch between operating modes. Crossover can occur from CV to CC or vice versa, depending on how the attached load resistance changes. Figure 3-3 shows the relationships between the variables.

For example, if the unit was initially operating in CV mode with the output voltage at the voltage set point and the load current below the  $I_{SET}$  and the attached load resistance began to decrease, the current would rise to meet this change in the load. The load current will increase in proportion to the decrease in the load resistance until the load current drawn reaches the current set point. At this point further decreases in load resistance (increased load current requirements) will cause the unit to cross over into CC mode where the output voltage will vary with changing load resistance and the load current will remain at the  $I_{SET}$  value.

The reverse operating mode change can also occur if the load resistance is increased to the point that the required load current drops below the  $I_{SET}$  value. At that point the power supply would crossover to CV mode and the load current would be free to vary as the load resistance changed.



**Figure 3-3** Operating Modes

**To set the voltage set point (VSET):**

1. Turn the 9-position mode control to the VOLTS position or press the rotary Adjust/Enter control if the 9-position mode control is already at the VOLTS position.

The voltage set point is blinking in the output voltage display. The output current will be displayed in the output current display.

2. Set the desired voltage value using the rotary Adjust/Enter control.

---

**Important:** If you can't get the set point to the desired level, you may need to change the set points for OVP.

---

3. Press the rotary Adjust/Enter control to transition to Fine Adjust mode.

The set point will blink faster to indicate fine adjust tracking mode.

4. Set the desired voltage value using the rotary Adjust/Enter control.

- Once the desired value has been set, press the rotary Adjust/Enter control to commit the setting.

---

**Important:** The control circuits have been designed to allow you to set the output voltage up to 105% over the model-rated maximum value. The power supply will operate within these extended ranges, but full performance to specification is not guaranteed.

---

**Quick Tip Remote operation uses these SCPI commands. See page 5-1.**

**The SCPI command (s) for these instructions are:**

```
[[:]SOURce[<channel>]]:VOLTage[:LEVEL][:IMMEDIATE]
[:AMPLitude]
```

---

**Important:** The maximum and minimum setting values of the output voltage are limited by the Over Voltage Protection and Under Voltage Protection settings.

---

**To set the current set point ( $I_{SET}$ ):**

- Turn the 9-position mode control to the AMPS position or press the rotary Adjust/Enter control if the 9-position mode control is already at the AMPS position.

The voltage set point is blinking in the output voltage display. The output current will be displayed in the output current display.

- Set the desired current value using the rotary Adjust/Enter control.
- Press the rotary Adjust/Enter control to transition to Fine Adjust mode.

The set point blinks faster to indicate fine adjust tracking mode.

- Set the desired current value using the rotary Adjust/Enter control.
- Once the desired value has been set, press the rotary Adjust/Enter control to commit the setting.

---

**Important:** The control circuits have been designed so that output current can be set up to 105% over the model-rated maximum values. The power supply will operate within these extended ranges, but full performance to specification is not guaranteed.

---

**The SCPI command (s) for these instructions are:**

```
[[:]SOURce[<channel>]]:CURRent[:LEVEL][:IMMEDIATE]
[:AMPLitude]
```

## Shipped Configuration (Local Operation)

The power supply is configured for local operation at the factory. See Table 3-3 for a summary of this configuration. For more information on default settings, see Table 3-9 on page 3-40.

**Table 3-3** Shipped Configuration

Local Control Configuration	Additional References
Use the front panel controls to adjust the output voltage and current set point settings.	See Chapter 3, “Local Operation” for front panel operation. See Chapter 4, “Analog Programming (APG) and Isolated Analog Programming (ISOL)” for analog programming procedures.
The OVP set point is adjusted at the front panel to 105% above the maximum rated output voltage.	See “Using Over Voltage Protection (OVP)” on page 3-26 for the adjustment procedure.

## Enabling the Output

Enabling the output on will also turn off the ALARM LED if the ALARM LED has been latched on due to an alarm triggering and automatically clearing. See “Alarms and Errors” on page 3-19.

### To enable the output power:

- ◆ Press the OUTPUT ENABLE Main button on the front panel or enter the SCPI command.

The OUTPUT ENABLE Main button will illuminate.

### To disable the output power:

- ◆ Press the OUTPUT ENABLE Main button when the OUTPUT ENABLE Main button is illuminated.

The output will be disabled and the LEDs will not be illuminated.

---

**Important:** The main output will not turn on if the shutdown function is activated. See “Using the External Shutdown Function” on page 3-31.

---

**Quick Tip** Remote Operation uses these commands. See page 5-1.

### The SCPI command (s) for these instructions are:

```
[ : ]OUTPut [ <channel> ] [ :POWER ] [ :STATe ]
```



## Enabling the Auxiliary Output

### To enable on the auxiliary output:

- ◆ Press the OUTPUT ENABLE Aux button on the front panel.  
The OUTPUT ENABLE Aux button will illuminate.

---

**Important:** The auxiliary output will not be enabled if the external AUX\_ON\_OFF signal line is being used to disable the auxiliary outputs. See “AUX Output and Isolated Analog Programming (ISOL) Connector” on page 4-20.

---

### To disable the auxiliary output:

- ◆ Press the OUTPUT ENABLE Aux button on the front panel again. The OUTPUT ENABLE Aux button will not be illuminated.

If the auxiliary output is activated, +5 V on J3.9 (+AUX1) and +15 V on J3.11 (AUX2) will be present with respect to Pin J3.2 or Pin J3.6 (COM ISOLATED). (See also “AUX Output and Isolated Analog Programming (ISOL) Connector” on page 4-20 for more details.)

### The SCPI command (s) for these instructions are:

```
[:]OUTPut [<channel>]:AUXiliary[:STATe]
```

## Output Auto Start Mode (Auto Restart)

The Auto Start mode establishes the state of the output of the power supply after recovery from a complete power cycle (all front panel LEDs are not illuminated).

If Auto Start mode is set to On, the power supply output will return to its previous value when the power supply is powered up again.

If Auto Start mode is set to Off, the power supply output will remain off after the power supply is powered up again.

### To change the Auto Start mode:

1. Press and hold the OUTPUT ENABLE Main button for 1 second. *AS ON* or *AS OFF* is displayed.
2. Switch the Auto Start mode.

### The SCPI command (s) for these instructions are:

```
[:]OUTPut [<channel>][:POWER][:STATe]:PowerON[:STATe]
```

## Auxiliary Auto Start Mode

The Auxiliary Auto Start mode determines the state of the auxiliary output after a complete power cycle (all front panel LEDs are not illuminated). With Auxiliary Auto Start mode turned to On, the auxiliary output will be activated after the power supply is powered up again.

### To define the Auxiliary Auto Start mode:

1. Press and hold the OUTPUT ENABLE Aux button for 1 second. *AUAS On* or *AUAS Off* is displayed.
2. To change to status to On or Off, press the OUTPUT ENABLE Aux button.

### The SCPI command (s) for these instructions are:

```
[:]OUTPut [<channel>]:AUXiliary:PowerON[:STATe]
```

## Alarms and Errors

Several conditions can cause alarms in the XG/XTR. Some conditions are:

- From user configurable features.
- Controlled in hardware and will trigger regardless of configuration.

All alarms, with the exception of the Fan alarm, will result in the output of the power supply being disabled. The Fan alarm does not affect the output.

When an alarm is triggered, the appropriate alarm message will begin blinking on the display and the Alarm **LED** will be illuminated. It is possible that more than one alarm will trigger at the same time. When this occurs, the alarm with the highest precedence will blink on the display. Table 3-4 lists the precedence of alarms. If the alarm is cleared and the event which caused the alarm has not been corrected, then the alarm may trigger again immediately. Fix the reason for the alarm before you clear it.

**Table 3-4** Alarm Order of Precedence

Alarm	Precedence	Output Latch	Maskable	Display
AC Fail	1 (Highest)	Yes	No	AC FA IL
Over Temperature Protection (OTP)	2	Yes	No	OT P Pro
Over Temperature Protection (OTP) Slave (1700 Watt only)	3	Yes	Yes	OT P Pro
Fan	4	No	Yes	FA n Pro
Fan Slave (1700 Watt only)	5	No	Yes	FA n Pro
Interlock	6	No	No	I n Loc
Over Voltage Protection (OVP)	7	Always	No	OV P Pro
Over Current Protection (OCP)	8	Always	No	OC P Pro
Foldback	9	Yes	Yes	FL d Pro
External Shutdown	10	No	Yes	S d PDL
Under Voltage Protection (UVP)	11 (Lowest)	No	Yes	UV P Pro
Flash Checksum Failure <sup>1</sup>	N/A	N/A	N/A	FLA FAI L

1. The Flash Checksum Failure alarms are an exception as they can only occur during boot up or recalling a user setting slot. If a checksum error is detected when recalling a user slot, no modification of settings will occur, and an error will be pushed to the SCPI error queue. If a checksum occurs at boot-up, then this checksum error can be cleared by doing a soft reset or by power cycling the unit.

## Clearing Alarms

### Clearing Triggered and Manual Alarms

**To clear a triggered alarm, use one of the following methods:**

- Turn the power supply Off and then On.
- Press and hold the rotary Adjust/Enter control for 3 seconds.

To clear a manual alarm:

1. Press and hold the rotary Adjust/Enter control for 3 seconds.

The *ALR CLR* message will be displayed on the front panel for a few seconds.

---

**Important:** When an alarm is cleared by using this method, only the current highest precedence alarm is cleared. If another alarm has occurred, then this alarm will now become the highest precedence alarm and will begin blinking on the display.

---

2. Repeat the alarm clearing until you have cleared all alarms.

### Clearing a Flash Failure Alarm

The Flash Failure alarm is the only exception for clearing alarms. If a flash failure occurs at boot time, it can only be cleared by a soft reset key combination press (see “Resetting the Power Supply” on page 3-40) or by power cycling the unit. If a checksum error is detected when recalling a user slot, no modification of settings will occur, and an error will be pushed to the SCPI error queue. The alarm will clear after a duration per the currently configured front panel timeout setting.

**To clear a triggered alarm, use one of the following methods:**

- Turn the power supply Off and then On.
- For failures that occur during a recall of user memory settings, wait the duration of the currently configured front panel timeout.
- Press and hold the reset key combination (Flash Fail ONLY). See “Resetting the Power Supply” on page 3-40.

**The SCPI command (s) for these instructions are:**

```
[:]OUTPut [<channel>]:PROtection:CLEar
```

## Clearing Automatic Alarms

Some alarms will clear automatically when the condition that caused the alarm is no longer present. When an alarm automatically clears, the output voltage and current displays will return to normal, but the ALARM LED will remain illuminated to indicate that an alarm has occurred. If an automatic alarm is triggered, the normal alarm clearing procedure still applies.

**To clear the ALARM LED after an automatic alarm has cleared, use one of the following methods:**

- Send the SCPI Clear Alarm command.
- Press the OUTPUT ENABLE Main button to reenable the output. The ALARM LED will no longer be illuminated.

For example, if one of the fans in the XG/XTR was temporarily blocked, causing a Fan alarm, then the blockage was cleared and the fans restarted, the alarm would clear. The output voltage and current displays would be in normal mode, but the ALARM LED would be illuminated. See “Front Panel ALARM LED” on page 3-21 for information on other events that affect the ALARM LED.

Alarms status is tracked in the SCPI status registers. For more details on how and where the alarms are tracked, see “Standard SCPI Register Structure” on page 5-38.

## Front Panel ALARM LED

The Alarm LED will illuminate due to one or more of the following events occurring:

- OTP has been tripped.
- A fan has stopped.
- OVP has tripped.
- OCP has tripped.
- UVP has tripped
- Interlock is open circuit.
- AC power falls out of range.
- Foldback has tripped.
- Persistent storage checksum is wrong (Flash Fail alarm).
- Internal malfunction of power supply.
- Any alarm has tripped and been cleared automatically.

The alarm LED will remain illuminated until the alarm is manually cleared (see “Clearing Triggered and Manual Alarms” on page 3-20) or by turning the main output on if the alarm has automatically been cleared.

## Alarm Masking

It is possible to completely disable some alarms through the use of the alarm mask. If an alarm is masked then this masking will prevent it from registering in the SCPI conditions registers as well as not triggering the alarm. The alarms that can be masked are identified in Table 3-4 on page 3-19. Setting the bit position (1) of an alarm will result in the alarm being enabled. Clearing the bit position (0) of an alarm will result in the alarm being masked/disabled.

For Example:

If you wanted to enable the OTP, Foldback and UVP alarms, you would take the foldback value of 256 and the UVP value of 1024 to get a mask of 1280. This is the value you would send with the SCPI command.

Control of the alarm mask is only available using the SCPI command.

### The SCPI command (s) for these instructions are:

```
[:]SYSTem[<channel>]:PROTection:MASK
```

The mask command takes a single parameter made up of the sum of the values for the alarms that are to be masked. See Table 3-5 for the alarm values associated with each maskable alarm.

**Table 3-5** Alarm Mask Bit Positions

Alarm	Bit Position	Value
Over Temperature Protection (OTP)	2	2
Over Temperature Protection (OTP) Slave (1700W only)	3	4
Fan	3	8
Foldback	8	256
External Shutdown	9	512
Under Voltage Protection (UVP)	10	1024

### The SCPI command (s) for these instructions are:

```
[:]SYSTem[<channel>]:PROTection:MASK
```

## Alarm Output Latching

When an alarm is triggered, the output will be disabled with the exception of the Fan alarm. When an alarm is cleared, the alarm output latch determines if the output should be re-enabled to the state before the alarm occurred or if the output should remain in the off state.

Where setting the bit position (1) of an alarm latch will result in output latching to the off state when the alarm is cleared and if cleared (0) output will be re-enabled to the state before the alarm triggered.

To define the values for the bit position you determine which alarms you want to latch. Read the value for this bit position from Table 3-6 and sum them together. The result is the alarm last mask, which you should send with the SCPI command.

For Example:

If you wanted to enable latching for OTP and Foldback you would take the OTP value of 2 and add it to the foldback value of 256 to get a mask of 258. This is the value you would send with the SCPI command.

The output latches are accessible through the SCPI command.

**The SCPI command (s) for these instructions are:**

```
[:]SYSTem[<channel>]:PROTection:LATCh
```

The latch command take a single decimal parameter made up of the sum of the values for the alarms to determine if they are to be latched in the off state on clearing. See Table 3-6 for the values associated with each latchable alarm.

**Table 3-6 Alarm Latch Bit Positions**

Alarm	Bit Position	Value
AC Fail	0	1
Over Temperature Protection (OTP)	1	2
Over Temperature Protection (OTP) Slave (1700 Watt only)	3	4
Foldback	8	256

## Setting Foldback Mode

Foldback mode is used to disable the output when a transition is made between the operating modes. The power supply will turn off/disable the output and lock in foldback mode after a specified delay if the power supply transitions into CV mode or into CC mode, depending on the foldback mode settings. This feature is particularly useful for protecting current or voltage sensitive loads. Foldback can be set to trigger a switch when transitioning from CV to CC mode or from CC to CV mode.

### To set the foldback protection and foldback delay time:

1. Turn the 9-position mode control to the FLD position or press the rotary Adjust/Enter control if the 9-position mode control is already at the FLD position.
2. Select the type of crossover that will cause foldback to trigger by using the rotary Adjust/Enter control.

If the mode selected is CC or CV mode, the foldback delay timer will start on a transition into the selected mode. If the mode selected is none, foldback is not enabled.

3. Press the rotary Adjust/Enter control when the desired mode has been selected.

The FLD LED will illuminate and  $dELd$  will be displayed in the output voltage display.

4. Adjust the desired delay time using the rotary Adjust/Enter control.

The range can be set from 0.50 seconds to a maximum of 50 seconds. The step size is in increments of 0.05 seconds when setting from 0.50 to 5 seconds and then in 1 second increments from 5 seconds to 50 seconds.

5. Once the desired foldback delay time has been selected, press the rotary Adjust/Enter control to commit the foldback delay setting.

### To disable foldback protection:

1. Turn the 9-position mode control to the FLD position or press the rotary Adjust/Enter control if the control knob is already at the FLD position.
2.  $FLd$  is displayed on the output voltage display and the output current display shows the current foldback trigger mode.
3. Turn the rotary Adjust/Enter control until  $nOnE$  is displayed in the output current display.



4. Press the rotary Adjust/Enter control to commit the setting once the desired value has been set.
5. The green FLD LED will turn off and the display will return to the normal display mode.

**The SCPI command (s) for these instructions are:**

```
[:]OUTPut [<channel>]:PROTection:FOLDback[:MODE]
```

```
[:]OUTPut [<channel>]:PROTection:FOLDback:LATCh
```

---

**Important:** If you set foldback while the output is enabled and the trigger you select is the same as the current operating mode, the foldback timer will begin counting immediately after the delay time has been set.

---

**3**

## Resetting Activated Foldback Protection

To reset activated and latched foldback protection, press and hold the rotary Adjust/Enter control for approximately 3 seconds.

**The SCPI command (s) for these instructions are:**

```
[:]OUTPut [<channel>]:PROTection:CLEAr
```

## Using Over Voltage Protection (OVP)

The OVP circuit protects the load in the event of an analog programming error, an incorrect voltage control adjustment, or a power supply failure. The OVP circuit monitors the output voltage at the output of the power supply and will disable the output whenever a preset voltage set point is exceeded. You can set the preset voltage trip point by using the 9-position mode control on the front panel or via one of the remote programming interfaces.

To prevent accidental tripping of the OVP while setting up, the firmware will prevent the OVP set point from being less than 105% of the voltage set point when in local set point control mode. When the XG/XTR is in VAP mode for defining voltage set point the set point limitation will be based on the VAP input signal level. The user should note it is possible to trip OVP in this mode if the OVP is configured when the analog programming source is off.

When the user attempts to configure an OVP setpoint that is less than 105% of the voltage set point via the front panel the set point will stop allowing the value to decrement. If the user attempts to configure an OVP set point that is less than 105% of the voltage set point via SCPI a -221, “settings conflict error” will be pushed onto the error queue.

## Defining the OVP Set Point

### To define the OVP set point:

1. Turn the power supply On.  
Ensure the voltage is lower than the desired set point.
2. Set the output to the desired voltage.  
OVP can be set without setting desired output voltage first.
3. Turn the 9-position mode control to the PRT position.  
*Prt OVP* is displayed.
4. Press the rotary Adjust/Enter control.
5. Turn the rotary Adjust/Enter control to set the upper limit protection. See “Coarse and Fine Adjustment Modes” on page 3-3.

---

**Important:** The OVP range is variable from  $V_{SET} + 5\%$  to  $V_{MAX} + 25\%$ .

---

6. Once the desired value has been set, press the rotary Adjust/Enter control to commit the setting.

### The SCPI command (s) for these instructions are:

```
[[:]SOURce[<channel>]]:VOLTage:PROTection[:OVERvoltage]  
[:LEVel]
```

If the output is between  $OVP_{set}$  and  $-5\%$ , an OVP warning message is possible when in APG mode.

## Using Under Voltage Protection (UVP)

---

**Important:** UVP will not be active for voltage set points that are less than 1% of model voltage.

---

The UVP prevents voltage settings below a set value. The UVP lets you create a voltage window of operation when used in conjunction with the OVP setting. The UVP range is variable from 0 V to  $OVP_{SET} - 10\%$ .

The UVP is a protection that becomes active after the output is enabled and a period of time has passed to allow the output to reach its set point value before the UVP protection begins monitoring. As with OVP if the voltage set point is determined by analog control (VAP) and the voltage strays to within 5% of the UVP set point then UVP Safe will trigger to warn the user that they are about to trigger the UVP alarm.

The period of time before the UVP monitoring is active after the output is enabled is determined by the rise-time delay for the model as listed in Table C-2, "Remote Operation" on page C-8 on the row called Up-prog Response Time, 0 - Vmax. Since the rise time is based on a purely resistive load the user should be aware that UVP triggering might be possible in capacitive or rectifier loads due to the rise time being longer. In these cases it is recommended that the user mask the UVP alarm until the rise time has elapsed and then unmask the alarm to allow UVP protection to be enabled during operation.

## Defining the UVP Set Point

### To define the UVP set point:

1. Turn the power supply On.
2. Set the output to the desired voltage.
3. Turn the 9-position mode control to the PRT position.  
*Prt UVP* is displayed.
4. Turn the rotary Adjust/Enter control until *Prt UVP* is displayed.
5. Press the rotary Adjust/Enter control to select the UVP for setting up.
6. Set up the lower limit protection using the rotary Adjust/Enter control.

---

**Important:** The UVP range is variable from 0 volts to  $OVP_{SET} - 10\%$ .

---

7. Once the desired value has been set, press the rotary Adjust/Enter control to commit the setting.  
See “Coarse and Fine Adjustment Modes” on page 3-3.

### The SCPI command (s) for these instructions are:

```
[[:]SOURce[<channel>]]:VOLTage:PROtection:UNDER[:LEVel]
```

## Over Current Protection (OCP)

The OCP alarm is a firmware alarm that is only configurable using the SCPI interface. The OCP triggers if the output current exceeds the OCP set point. Because the OCP alarm is a firmware based alarm it has a latency before detection of the condition can occur. The user should be aware of this latency and take this into consideration when relying on OCP to protect a sensitive load. The maximum period for detecting an OCP condition is 300 ms.

OCP is fixed at 110% of rated current.

## Using Over Temperature Protection Lock (OTP)

The OTP lock protects the power supply in the event of an over temperature alarm. This alarm could be caused by ventilation restriction or overheating due to fan failure.

Two modes are available:

- Auto recovery (OTP OFF) where the power supply turns on again after cooling down.
- Latch mode (OTP ON) where you will need to reset the unit by turning the front panel power switch to Off and then On again.

If the OTP is activated, the main output will turn off and *PrO OTP* (over temperature protection) will blink on the display. The OTP alarm is an alarm that will auto recover when the temperature falls back into normal bounds.

### Defining the OTP Mode

**To define the OTP lock:**

1. Turn the 9-position mode control to the PRT position. PrO OUP is displayed.
2. Turn the rotary Adjust/Enter control until *PrO OTP* is displayed.
3. Press the rotary Adjust/Enter control to display *OTP On or Off*.
4. Turn the rotary Adjust/Enter control to change to On or Off.
5. Press the rotary Adjust/Enter control.

**The SCPI command (s) for these instructions are:**

```
[:]SYSTem[<channel(s)>]:PROTection:LATCh
```

### Resetting in Latch Mode

To reset the power supply if the OTP alarm is tripped and the OTP mode is set to On (latching enabled), press and hold the rotary Adjust/Enter control for approximately 3 seconds.

**The SCPI command (s) for these instructions are:**

```
[:]OUTPut[<channel(s)>]:PROTection:CLEar
```

```
[:]SYSTem[<channel(s)>]:PROTection:LATCh
```

---

## Using the External Shutdown Function

Use the external shutdown function to enable or disable the output of the power supply via a logic level signal. When the external shutdown is triggered, the power supply will display *SD POL* on the output voltage and current displays. The external shutdown is useful for making adjustments to either the load or the power supply without shutting off the power supply or for using the power supply as part of a larger test system in which digital or analog control is required.

### Activating the External Shutdown Function

To activate the external shutdown function, use the AUX output supply provided on the Analog Programming Connector J3. This input has a user selectable polarity with logic low input from 0.0V to 1.2V and logic high from 2.0V to 15V. The control signal for this input must be capable of sinking 10mA minimum. This input is also compatible with the use of dry contacts, where a short is logic low and an open is logic high. The input lines of the shutdown circuit are fully optically isolated. See page C-8 for specifications.

Once the External Shutdown has been triggered, the display will blink the *SD POL*.

### Controlling the External Shutdown Function

The external shutdown circuit accepts a voltage or dry contact control (high or low logic level) to enable or disable the power supply output. Make connections for the signals at the AUX Output and Isolated Analog Programming Connector on the rear panel. (See “AUX Output and Isolated Analog Programming (ISOL) Connector” on page 4-20 for more information.)

**To activate the shutdown function:**

Connect the control signal source to the Shutdown pin (J3.12) on the Aux Output and Isolated Analog Programming Connector with the control circuit ground connected to Isolated Ground pin (J3.6).

The External Shutdown pin is pulled high internally (normally high). Therefore, if this feature is not used, the polarity should be set to 1 to avoid false triggering. (See “Defining the Polarity of the External Shutdown Signal” on page 3-32 for instructions.)

## Defining the Polarity of the External Shutdown Signal

1. Turn the 9-position mode control to the PRT position or press the rotary Adjust/Enter control if the control knob is already at the PRT position.

*Pr*  $\square$  *OUT* is displayed on the output voltage display.

2. Turn the rotary Adjust/Enter control until *Pr*  $\square$  *SD* is displayed.
3. Press the rotary Adjust/Enter control to display *SD*  $\square$  (shutdown on logic 0) or *SD*  $\square$  *1* (shutdown on logic 1).
4. Press the rotary Adjust/Enter control to commit the desired polarity setting.

For example: If you set the shutdown logic to 1 (*SD*  $\square$  *1*) and apply a logic high (greater than 1.2 Vdc) to pin J3.12 relative to pin J3.6 on the ISOL connector, the power supply will shut down.

Conversely, if you set the shutdown logic to 0 (*SD*  $\square$ ), the power supply will only operate when you have a logic high (greater than 1.2 Vdc) to pin J3.2 relative to pin J3.6.

---

**Important:** There is an internal pullup resistor inside the shutdown circuit so the shutdown polarity should be set to 0 if it is not being used.

---

### The SCPI command (s) for these instructions are:

```
[:]OUTPut [<channel>]:POLarity
```



## Interlock Function

The Interlock function can be used to wire an external shutoff switch that can be used to enable or disable the power supply output. When the switch is closed the power supply will operate normally. If the switch is opened, the power supply will trigger the interlock alarm. The output will be disabled, the display will blink *! n LDC*, and the ALARM LED will illuminate. This alarm will automatically clear when the switch closes again, and the output will automatically be restored to its pre-alarm state (either enabled or disabled). The interlock function can be enabled or disabled using a SCPI command. Common applications include an emergency shutoff switch or a door switch.

Connect the switch between pins J3.14 and J3.15 on the AUX Output and Isolated Analog Programming Connector.

3

## Defining the Interlock Mode

The Interlock mode is controlled via SCPI commands. There is no front panel access for enabling or disabling the Interlock functionality. See “Interlock Enable/Disable” on page 5-70.

**The SCPI command for setting the Interlock mode to On and Off is:**

```
[:]SENSe[<channel>]:PROTection:INTeRlock[:STATe]
```

## Output Protection

The output voltage and the output current can be programmed (preset) to automatically start at zero Volts and zero Amps upon power-up and upon output enable. Also, each can be reprogrammed to disable the automatic reset to zero.

**Note: With the M10 Option, the power supply voltage output is preset to 0 Volts.**

## Programming Voltage Output Preset

**To Enable/Disable automatic reset to 0 Volts:**

1. Turn the rotary Adjust/Enter control to PRT and press.
2. Turn again until *P r 0 O U T P* is displayed.
3. Press to display *O U T P V O L T*.

4. Turn to display *VOL On* or *VOL OFF*.
5. Press to commit the selected setting.

**Important:** This single front panel operation affects both power on and output enable. However, when using SCPI, there is a separate command for each.

**The SCPI command to query or enable/disable the 0 Voltage Output Preset at power-on is:**

```
[:]SYSTem[<channel>]:PON:VOLTage {?|ON|OFF}
```

**The SCPI command to query or enable/disable the 0 Voltage Output Preset upon output enable is:**

```
[:]SYSTem[<channel>]:PON:ENABle:VOLTage {?|ON|OFF}
```

## Programming Current Output Preset

**To Enable/Disable automatic reset to 0 Amps:**

1. Turn the rotary Adjust/Enter control to PRT and press.
2. Turn again until *Pr0 OUTP* is displayed.
3. Press to display *OUTP CURr*.
4. Turn to display *CURr On* or *CURr OFF*.
5. Press to commit the selected setting.

**Important:** This single front panel operation affects both power on and output enable. However, when using SCPI, there is a separate command for each.

**The SCPI command to query or enable/disable the 0 Current Output Preset at power-on is:**

```
[:]SYSTem[<channel>]:PON:CURRent {?|ON|OFF}
```

**The SCPI command to query or enable/disable the 0 Current Output Preset upon output enable is:**

```
[:]SYSTem[<channel>]:PON:ENABle:CURRent {?|ON|OFF}
```

## Power On Status Signal

Power On Status signal indicates a fault condition in the power supply. Power On Status signal is a TTL output signal at Pin J2.13 with reference to COM ISOLATED (Pin J2.2 or Pin J2.6).

During normal operation, the Power On Status signal will be high. If the output is disabled for any reason, the Power On Status signal will go low.

The following conditions will set the Power On Status to a low level:

- AC fail
- Over Voltage protection (OVP)
- Under Voltage Protection (UVP)
- Over Current Protection (OCP)
- Over Temperature protection (OTP)
- Foldback protection
- Interlock
- Output Off
- Shutdown activated (rear panel shutdown).
- Internal hardware malfunction Fan failure

**3**

## Hardware Malfunction Alarms

The power supply will turn off the output. An error message will be displayed in the event that:

- OVP trips
- Voltage deviation in CV mode reaches more than  $\pm 5\%$  from the set level.<sup>1</sup>
- Current deviation in CC mode reaches more than  $\pm 5\%$  from the set level.<sup>1</sup>

---

1. These two forms of hardware malfunction are only monitored in the corresponding APG mode.

## Current Configuration Memory Settings

The power supply will save the unit settings at the time of power down. These settings will be loaded when the power is restored to the unit or the power supply is powered up again. Table 3-7 lists the settings that are saved and recalled on a power cycle event.

**Table 3-7** Power Cycle Saved/Recalled Settings

Voltage Setpoint
Current Setpoint
Voltage Output Protection
Current Output Protection
Over Voltage Protection (OVP)
Under Voltage Protection (UVP)
Over Temperature Protection (OTP)
Autostart OUTPUT ENABLE Main
Autostart OUTPUT ENABLE Aux
Foldback Mode
Foldback Delay
Shutdown Logic
Voltage Analog Programming (VAP) Mode
Voltage Analog Programming (VAP) Level
Current Analog Programming (CAP) Mode
Current Analog Programming (CAP) Level
Remote Programming Interface
Local Lock
PSU (Power Supply) Address
Data Rate (BPS)
Alarm Latches
Front Panel Timeout

## User Setting Memory Locations

There are three user setting memory locations available for storing frequently used configurations. These user setting memory locations help to facilitate multiple users of an XG/XTR power supply who have different setups or when multiple loads are used that have different requirements. Table 3-8 lists the values that are stored in each user setting memory location.

**Table 3-8** User Accessible Saved/Recalled Settings Voltage Setpoint

Voltage Setpoint
Current Setpoint
Voltage Output Protection
Current Output Protection
Over Voltage Protection (OVP)
Over Temperature Protection (OTP)
Autostart OUTPUT ENABLE Main
Autostart OUTPUT ENABLE Aux
Foldback Mode
Foldback Delay
Shutdown Logic
Voltage Analog Programming (VAP) Mode
Voltage Analog Programming (VAP) Level
Current Analog Programming (CAP) Mode
Current Analog Programming (CAP) Level
Current Sharing Mode
Alarm Latches
Front Panel Timeout

## Saving User Setting Memory Locations

### To save user setting memory locations:

1. Turn the 9-position mode control to the SAV position.  
*SAVE* is displayed on the output voltage display with a number indicating a preset position which is displayed on the output current display.
2. Turn the rotary Adjust/Enter control to select a preset position from 1 to 3.
3. Press the rotary Adjust/Enter control.  
*SAVE done* is displayed on the output voltage display.

4. The setting has now been saved to the selected user setting memory location.

**The SCPI command (s) for these instructions are:**

\*SAV <setting\_location>

or

[:]SYSTem[<channel>]:SAVE <setting\_location>

## Recalling User Setting Memory Locations

This feature recalls settings that were previously saved.

**To load user setting memory locations:**

1. Turn the 9-position mode control to the RCL position.  
*rCL* is displayed on the output voltage display with a number indicating a preset position on the output current display.
2. Turn the rotary Adjust/Enter control to select a preset position from 1 to 3.
3. Press the rotary Adjust/Enter control.

*rCL done* is displayed on the output voltage display.

The settings in the selected user setting memory locations have now been applied to the power supply.

**The SCPI command (s) for these instructions are:**

\*RCL <setting\_location>

or

[:]SYSTem[<channel>]:RECall <setting\_location>

Three user setting memory locations are available and one user setting memory location is saved automatically before AC power shutdown. This user setting memory location will be loaded after AC power is restored.

## Local Lockout

Local lockout is a feature that allows the front panel to be locked so that accidental button presses are ignored. This feature is often used to lockout the front panel when you are controlling the power supply from a remote location. When in local lockout mode, the front panel will display `LOC|Loc` whenever a button is pressed or a knob is turned.

### Enabling Local Lockout

#### To enable local lockout:

1. Turn the 9-position mode control to the PGM position or press the rotary Adjust/Enter control if the control knob is already at the PGM position.

The display will show `rE|` in the output voltage display and the selected remote interface in the output current display.

2. Turn the rotary Adjust/Enter control until the display shows `LOC|Loc`.
3. Press the rotary Adjust/Enter control.
4. Turn the rotary Adjust/Enter control until the display shows `LOC|On`.
5. Press the rotary Adjust/Enter control. Local lockout has been enabled.

#### The SCPI command (s) for these instructions are:

```
[:]SYSTem:REMOte:STATe
```

### Disabling Local Lockout

#### To disable local lockout:

1. Turn the 9-position mode control to the PGM position or press the rotary Adjust/Enter control if the control knob is already at the PGM position.

The display will show `rE|` in the output voltage display and the selected remote interface in the output current display.

2. Turn the rotary Adjust/Enter control until the display shows `LOC|OFF`.
3. Press the rotary Adjust/Enter control.  
Local lockout will be disabled after power-cycling the power supply.

#### The SCPI command (s) for these instructions are:

```
[:]SYSTem[<channel(s)>]:REMOte:STATe
```

## Resetting the Power Supply

The reset is used to clear the parameters to the factory default values.

### Soft Reset

The soft reset is used to set the parameters (see Table 3-9) to the default values, but it does not reset the calibration constants

#### To perform a soft reset:

1. Turn the power supply to Off then On.

When the unit is powering on, `0000 0000` is displayed on the output voltage and current displays.

2. Press the key combination of both OUTPUT ENABLE Main button and OUTPUT ENABLE Aux button and hold continuously for 3 seconds in order to execute.

If the flash fail alarm triggers, it is also possible to reset the power supply. The front panel should display `PSU 5 r5`.

3. Once a reset has been triggered, the output voltage display shows `PSU Err` for 1 second.

The model number will be displayed for 1 second and then return to normal mode.

After executing a reset, the power supply's settings are restored to the default settings but retain the calibration data. Table 3-9 lists the default settings.

**Table 3-9** Power Supply Default Settings

Parameter	Setting
Address	1
Data rate (Kbps)	9.6
Communication mode	RS-232
Vout setting	0 V
Iout setting	0 A
Output	Off
AUX Out	Off
Trigger	Off
Ext. On/Off Polarity	Negative
Auto start mode	Off
AUX Auto start mode	Off
OVP	Maximum



**Table 3-9** Power Supply Default Settings

<b>Parameter</b>	<b>Setting</b>
UVP	0 V
Foldback trigger	None
Foldback delay	0.5 s
Current Share Mode	Controller
Alarm Output Latches	263 (0 x 107, all latches enabled)
Alarms Mask	2047 (0 x 7FF, all enabled)
Interlock	Disabled
Voltage Analog Programming	Off
Voltage APG Scale	10 V
Current Analog Programming	Off
Current APG Scale	10 V
Voltage Output Protection	Off <b>(except M10 Option: always On)</b>
Current Output Protection	Off <b>(except M10 Option: always On)</b>

## Using Multiple Power Supplies

---



### **WARNING: Shock hazard**

There is a shock hazard at the load when using a power supply at an output of greater than 40V or a combined output of greater than 40V. To protect personnel against accidental contact with hazardous voltages created by a series connection, ensure that the load, including connections, has no live parts which are accessible. Also ensure that the insulation rating of the load wiring and circuitry is greater than or equal to the maximum *or combined* output voltage of the power supply.

---



### **CAUTION: Equipment damage**

Do not connect power supplies from different manufacturers in parallel or in series.

---

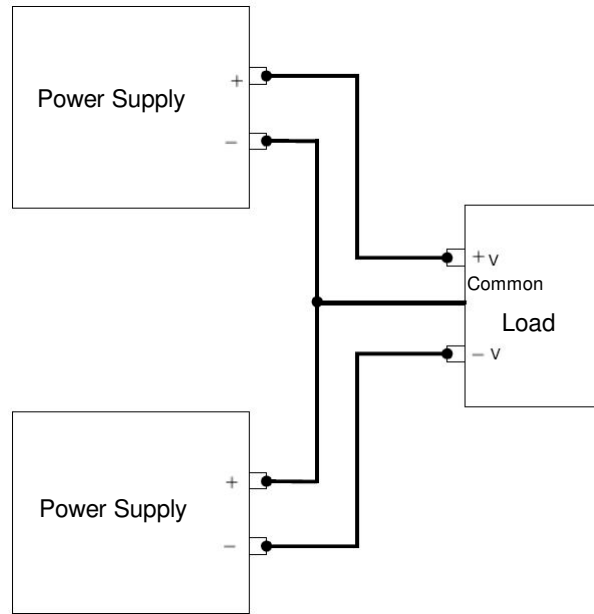


### **CAUTION: Equipment damage**

The remote programming inputs are internally referenced to the power supply's negative output. Do not connect remote programming ground lines to the power supply's positive output.

---

You can operate power supplies of the same model with the outputs in series to obtain increased load voltage or with the outputs in parallel to obtain increased current, also called current sharing. Split supply operation gives you two positive outputs, or a positive and a negative output. See Figure 3-5 on page 3-43. When using multiple supplies in series or parallel, they will not meet the single unit specifications in this Manual.



**Figure 3-4** Split Supply Operation

3

## Configuring Multiple Supplies for Series Operation

A maximum of two power supplies of the same rating can be connected in series to increase the output voltage.



### **CAUTION: Equipment damage**

When two power supplies are connected in series, they should be programmed to the same output voltage to prevent damage to the lower voltage supply at short circuit condition.

---

## Load Considerations



### **CAUTION: Equipment damage**

Use properly rated diodes to protect the power supply from damage while driving inductive loads..

---

#### INDUCTIVE LOADS:

To prevent damage to the power supply from inductive kickback, connect a diode (rated at greater than the supply's output voltage and current) across the output. Connect the cathode to the positive output and the anode to return. Where positive load transients, such as back EMF from a motor may occur, a second diode in series with the output is recommended to protect the power supply.

#### BLOCKING and FREE WHEELING DIODES:

The Peak Reverse Voltage ratings should be a minimum of 2-3 times the power supply maximum output voltage. The Continuous Forward Current rating should be a minimum of 1.5 times the power supply maximum output current. Heatsink may be required. There also may be a need for higher voltage rated parts, dependent on load circuit design and inductor values.

## Connecting to the Load in Local Sensing Mode

Connect the negative (-) output terminal of one power supply to the positive (+) output terminal of the next power supply. See Figure 3-5 for a representation of series operation.



### Connecting to the Load in Remote Sensing Mode

Connect the negative (-) output terminal of one power supply to the positive (+) output terminal of the next power supply. The more positive supply's positive sense line should connect to the positive terminal of the load (or distribution point). Its return sense line should connect to the connection between the two units at the same spot as the negative supply's positive sense line. The return sense line of the negative supply should be connected to the return of the load. See Figure 3-6.



#### CAUTION: Equipment damage

Do not connect sense lines through relays.

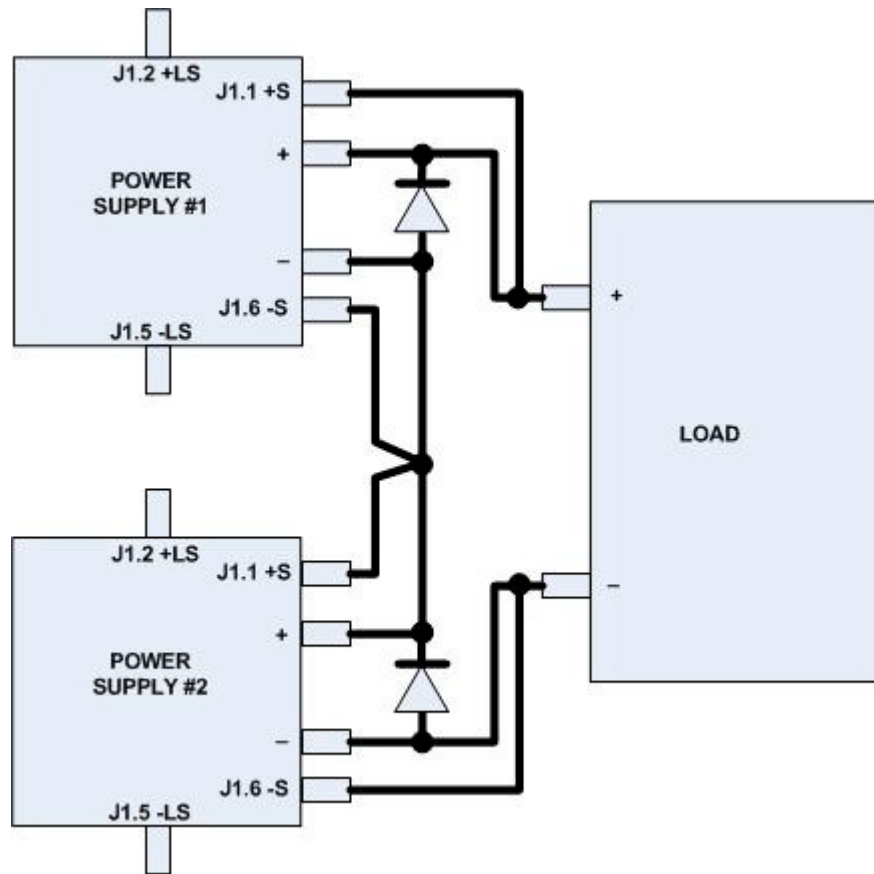


Figure 3-6 Load Connections in Remote Sensing Mode

## Configuring Multiple Supplies for Current Sharing Operation (APG Method)

Up to four power supplies can be connected in parallel to increase the output current. One of the units will operate as the master unit and the remaining units will operate as slave units controlled by the master unit. The master unit uses the analog programming lines to set the output voltages and currents of the slave units to match its output.

In remote digital operation, only the master unit can be programmed remotely while the slave units that are connected remotely will only provide voltage, current and status readback information.

In APG current sharing topologies, only the master unit can be programmed using any of the input methods (front panel, remote digital, or analog programming control). The slave unit(s) voltage and current output(s) are determined by the master unit through the REF\_I input to each slave unit. The readback using any of the monitoring methods (front panel display, user monitor lines or SCPI measure commands) of each unit (master or slave) will provide individual unit status, not system status.

---

**Important:** If current sharing is not being used, the unit must be configured as a controller. Failure to do so will result in unpredictable operation.

---

### Setting up the Controller Unit

Set the output voltage of the master unit to the desired voltage. Program the current set point of the master unit to the desired load current set point divided by the number of parallel units. During operation, the master unit operates in Constant Voltage mode, regulating the load voltage at the programmed output voltage. Send the Current share SCPI command or use the following instructions to program front panel current share setup:

1. With the 9-position mode control at the PGM position, press the rotary Adjust/Enter control.  
rE| is displayed on the output voltage display.
2. Turn the rotary Adjust/Enter control to select [Curr Share] and press the Adjust/Enter control.  
[Share] is displayed on the output voltage display.
3. Turn the rotary Adjust/Enter control to select [On] in the output current display.

4. Press the rotary Adjust/Enter control to commit the setting.

**The SCPI command (s) for these instructions are:**

```
[[:]SOURce[<channel>]]:COMBine:CSHare[:MODE]
```

### Setting up the Slave Units

The output voltage and current of the slave units should be programmed to maximum value. During parallel operation, the slave units operate as a controlled current source following the controller unit's output current.

All slave units must be configured with the SCPI command to enable current sharing, or use the following instructions to program front panel current share setup:

1. With the 9-position mode control at the PGM position, press the rotary Adjust/Enter control.  
rE is displayed on the output voltage display.
2. Turn the Adjust/Enter control to select "Current Share" and press the Adjust/Enter control.  
CSHr is displayed on the output voltage display.
3. Turn the rotary Adjust/Enter control to select 5.0A in the output current display.
4. Press the rotary Adjust/Enter control to commit the setting.

**The SCPI command (s) for these instructions are:**

```
[[:]SOURce[<channel>]]:COMBine:CSHare[:MODE]
```

---

**Important:** The slave unit discussed here is not the same as the remote interface slave described in chapter 5.

---

### Setting Over Voltage Protection (OVP)

The master unit's OVP should be programmed to the desired OVP level. The OVP of the slave units should be programmed to a higher value than the master OVP. When the controller unit shuts down, it will program the outputs of the slave units to zero volts. If a slave unit shuts down, only that unit would shut down and the remaining slave units would supply all the load current if possible.



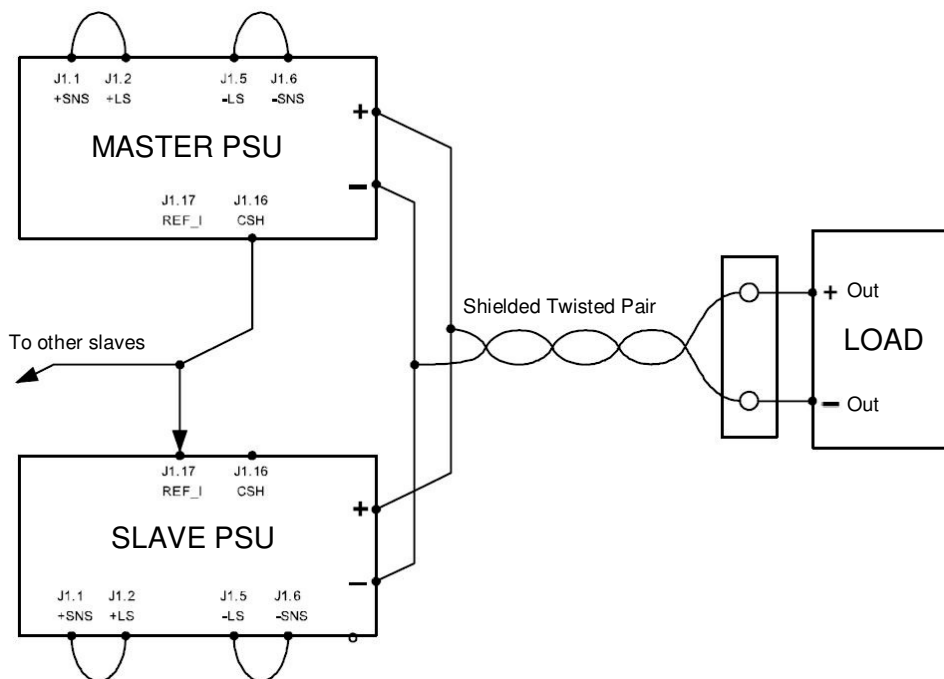
## Setting Foldback Protection

Foldback protection is only available on the master units as the slaves operate in constant current mode. They should never crossover into constant voltage mode. If foldback is triggered on the master unit, when its output shuts down, it will program the slave unit's output to zero volts.

## Connecting to the Load in Local Sensing Mode (Parallel Control Method)

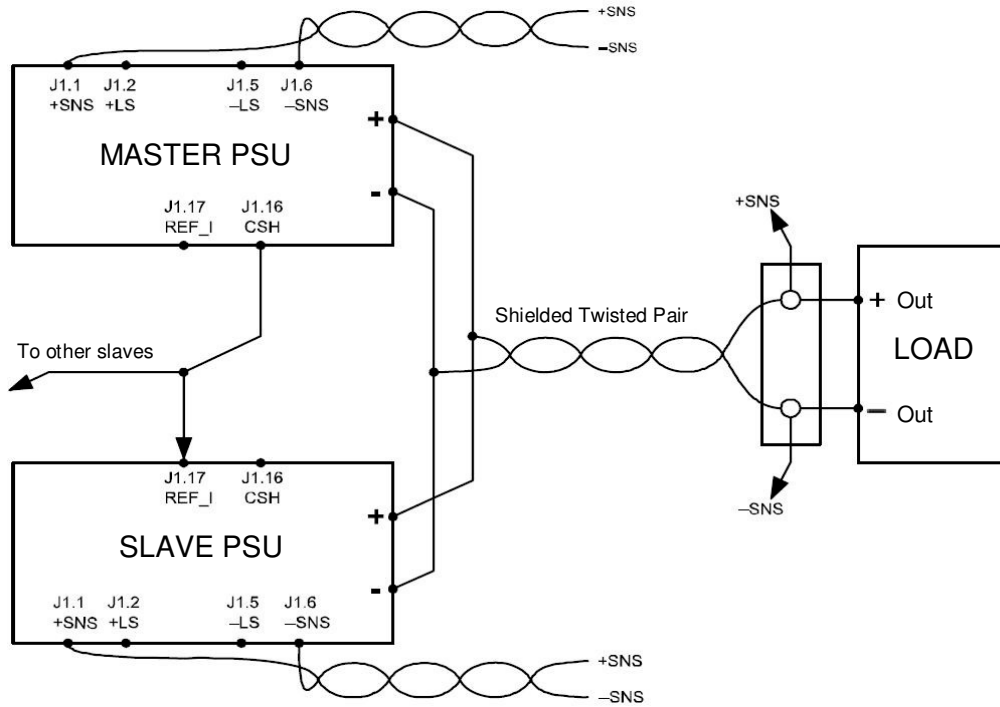
Connect the power supplies in parallel to obtain a single output supply with a higher output current set point. Set all of the outputs to the same voltage before connecting the positive (+) and negative (-) terminals in parallel. The total current available is the sum of the maximum currents of each power supply.

3



**Figure 3-7** Load Connections in Local Sensing Mode

## Connecting to the Load in Remote Sensing Mode (Parallel Control Method)



**Figure 3-8** Load Connections in Remote Sensing Mode (Parallel Control Method)

# 4

## **Analog Programming (APG) and Isolated Analog Programming (ISOL)**

Chapter 4, Analog Programming (APG) and Isolated Analog Programming (ISOL), provides information and procedures for analog and isolated analog programming of the power supply.

## Introduction

The rear panel connectors J1 and J3 provide an option to control and monitor the output of the power supply with analog signals. Connector J1 provides a non-isolated analog interface where all signals are referenced to the negative output terminal of the power supply. Connector J3 is an isolated interface and also provides an isolated auxiliary voltage output to aid analog programming.

## Analog Programming (APG) of Output Voltage and Output Current

Analog programming allows control of the power supply's output voltage, output current or both to be controlled from analog input sources. As the programming source is varied within the configured analog programming range (2-10 volts/k $\Omega$  max), the power supply's output varies proportionally over its output range. For example, if you set the programming scale to 10 V voltage source and apply 5 V to the programming pins, the power supply will be programmed to 50% of the output capability for your power supply.

While analog programming mode is configured, you will not be able to make adjustments to the set points from the front panel or through the remote interfaces.

The front panel will display AnPr in the output current display when the 9-position mode control is turned to VOLTS or AMPS positions for the parameter(s) that are configured to be controlled by analog programming. If an adjustment of a parameter controlled by APG is attempted using a SCPI command, a “-221 Settings Conflict” error will be pushed onto the error queue.

Using analog programming requires that you make connections to the Isolated Analog Programming Connector or Analog Programming Connector on the rear panel of the power supply. Depending on your model, see “Rear Panel Connectors on 850 Watt Models” on page 1-7 or “Rear Panel Connectors on 1500 and 1700 Watt Models” on page 1-9.

## Remote Programming Options

### Analog Monitor Signals

There are four monitor lines for analog programming the pin name and the related APG mode, which are listed in Table 4-1. All of these lines are provided to give analog feedback. The output from these monitor lines is a value scaled to the Analog Programming level set for the corresponding analog programming type. For example, the voltage monitor and isolated voltage monitor lines are both scaled to the analog programming level that is set in the VAP mode.

**Table 4-1** Monitor Lines

Related APG Mode	Reference Line Name	Connector
Non-Isolated Voltage Analog Programming	VOL_MON	J1.13
Isolated Voltage Analog Programming	IS_MON_VOL	J3.5
Non-Isolated Current Analog Programming	CUR_MON	J1.14
Isolated Current Analog Programming	IS_MON_CUR	J3.10

**Important:** Analog control monitor lines will reflect the output of the power supply even when the unit is not set to operate in analog programming mode.

**Important:** Isolated monitor lines are only valid when isolated analog programming modes are used for the respective voltage and current control. If local (front panel) control is used or non-isolated APG is used, these values will be inaccurate and should not be used for monitoring. Conversely, if isolated APG is used, the non-isolated monitor lines will be inaccurate.

## Auxiliary Outputs

The auxiliary outputs are an additional isolated source. The auxiliary output has two outputs: +5 V output on J3.9 and a +15 V output on J3.11. The auxiliary output operates independently of the main output. It is enabled or disabled from the front panel by pressing the OUTPUT ENABLE Aux button. When the Aux output is enabled, the OUTPUT ENABLE Aux button is illuminated. Like the main output of the power supply, the Aux also has the ability to Autostart at power up. See “Output Auto Start Mode (Auto Restart)” on page 3-17 and “Auxiliary Auto Start Mode” on page 3-18 for details on controlling this feature.

Table 4-2 provides a summary of the options available for programming output voltage and current set point using an analog source.

**Table 4-2** Remote Programming Options

<b>Control of...</b>	<b>Programming Scale<sup>1</sup></b>	<b>For more info...</b>
Output voltage	2-10 V Voltage source (adjustable)	See page 4-10.
Current set point	2-10 V Voltage source (adjustable)	See page 4-12.
Output voltage	2-10 k $\Omega$ Resistive source (adjustable)	See page 4-15.
Current set point	2-10 k $\Omega$ Resistive source (adjustable)	See page 4-17.

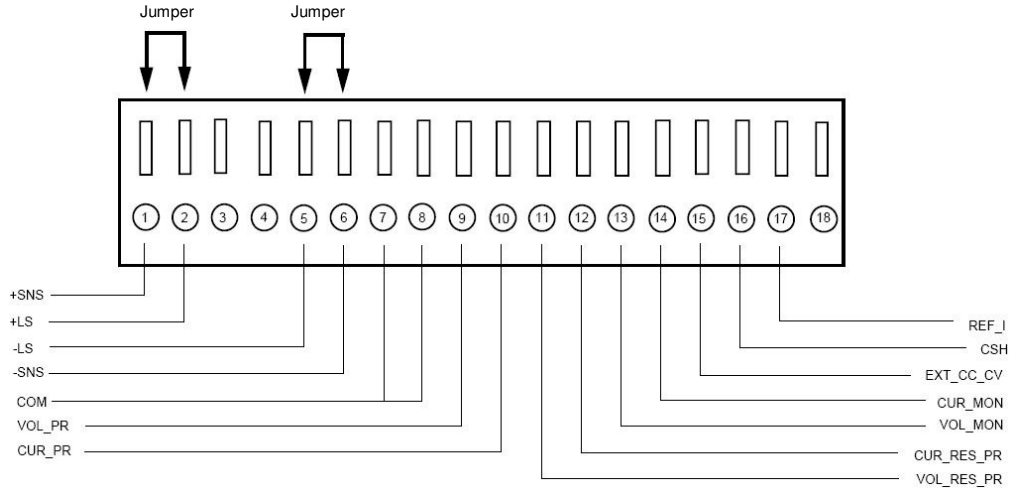
1. The resolution can be adjusted in increments of 0.1 volts.

## Analog Programming (APG) Connector J1

The APG connector is an 18-pin connector. See Figure 4-1.

The APG connector provides access to the following functions:

- Sense control
- Analog programming and monitoring.



**Figure 4-1** APG Connector Terminals

**Table 4-3** APG Pins and Functions J1

Pin	Reference	Function
J1.1	+SNS Positive (+)	Sense } Local Sense } Jumper. Factory default condition.
J1.2	+LS Positive (+)	
J1.3	-NC	
J1.4	-NC	
J1.5	-LS Negative (-)	Local Sense } Sense } Jumper. Factory default condition.
J1.6	-SNS Negative (-)	
J1.7	COM Analog Common	Same as power supply negative sense (-SNS)
J1.8	COM Analog Common	Same as power supply negative sense (-SNS)

**Table 4-3** APG Pins and Functions J1

Pin	Reference	Function
J1.9	VOL_PR	Analog Voltage Programming Input
J1.10	CUR_PR	Analog Current Programming Input
J1.11	VOL_RES_PR	Voltage Resistive Programming Input
J1.12	CUR_RES_PR	Current Resistive Programming Input
J1.13	VOL_MON <sup>1</sup>	Voltage Monitor. The scale of this output is set by the APG voltage input range selected (see Important note below).
J1.14	CUR_MON <sup>1</sup>	Current Monitor. The scale of this output is set by the APG current input range selected (see Important note below).
J1.15	EXT_CC_CV	External CC/CV. Indicates the state of the operate mode. When in CV mode, logic high is output and when in CC mode, logic low is output. Logic is TTL/CMOS compatible.
J1.16	CSH	Current Share. Used to hook up units for current sharing. Output from master unit. Slave units should be left open.
J1.17	REF_I	Current Reference Input. Slave input from current share output on the master unit.
J1.18	NC	

1. Important: Non-isolated monitor lines are only valid in local control, digital remote and non-isolated analog programming modes for the respective voltage and current control. If isolated analog programming is used, the isolated monitor lines should be used as the non-isolated monitoring lines will not accurately reflect the output state of the power supply.



## Making Control Connections



### CAUTION: Equipment damage

Before making connections from external circuits to the Analog Programming Connector, turn the front panel power switch to Off and wait until the front panel displays are not illuminated.



### CAUTION: Equipment damage

Program/monitor signal and return are internally connected to the power supply negative output (-S). Do not attempt to bias these away from that potential.

#### To connect the output wires to the APG and DC output connector:

1. Insert a 3/32 inch slot-head screwdriver into the orange-colored box of the connector until the end of the spring is reached. See Figure 4-2.
2. Hold the connector open and insert the applicable output wire.
3. Remove the screwdriver.

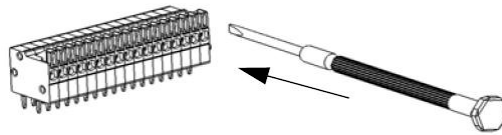


Figure 4-2 Inserting Screwdriver into Spring Terminal Block

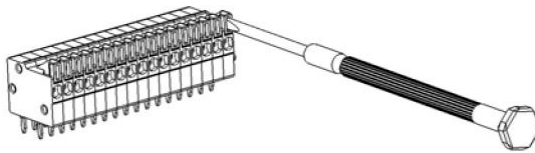


Figure 4-3 APG and DC Output Connector

## Wiring



### **WARNING: Shock hazard**

There is a potential shock hazard at the output when using a power supply with a rated output greater than 60 V. Use load wiring with a minimum insulation rating equivalent to the maximum output voltage of the power supply. For example, select TEW, 105 °C, 600 V wiring for use with a 600 V 1.4 Amp or 2.8 Amp power supply.

---

For most connectors and jumpers, use any suitable wire such as 20 to 26 AWG stranded wire. For lowest noise performance, use shielded twisted pair wiring of 20 to 26 AWG of the shortest length possible. Ground the shield to pin J1.7 (analog common) on the Analog Programming Connector or to the chassis via one of the Analog Programming Connector screws.

## Analog Programming Mode

For more details about connections for your particular model, see “Rear Panel Connectors on 850 Watt Models” on page 1-7 or “Rear Panel Connectors on 1500 and 1700 Watt Models” on page 1-9.

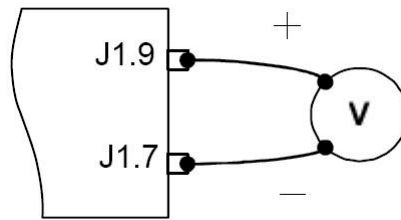


### CAUTION: Equipment damage

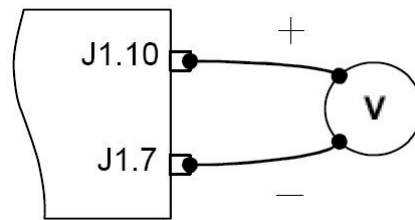
The program/monitor signal and return are internally connected to the power supply's negative output. Do not attempt to bias these away from that potential. See “Making Control Connections” on page 4-7.

## Analog Programming With External Voltage Source

The pin numbers are described in Table 4-3 on page 4-6.



**Figure 4-4** Programming Output Voltage using an External Voltage Source



**Figure 4-5** Programming Output Current using an External Voltage Source

## Voltage-Controlled Voltage APG Setup

### Activating APG Voltage Mode

#### To activate APG voltage mode using an external voltage source:

1. Turn the 9-position mode control to the VAP position or press the rotary Adjust/Enter control if the mode control is already at the VAP position.  
*VAP* is displayed on the output voltage display.
2. Turn the rotary Adjust/Enter control to select *Un IS* (voltage source from non-isolated connector).
3. Press the rotary Adjust/Enter control to commit the selected mode. *LE Un* is displayed on the output voltage display.
4. Once the desired level has been selected, press the rotary Adjust/Enter control to commit the change.  
The display will return to the normal display.

### Deactivating APG Voltage Mode

#### To deactivate the APG voltage mode:

1. Turn the 9-position mode control to the VAP position or press the rotary Adjust/Enter control if the mode control is already at the VAP position.
2. *VAP* is displayed on the output voltage display.
3. Turn the rotary Adjust/Enter control to select *nonE*.
4. Press the rotary Adjust/Enter control to commit the change.  
The display will return to the normal display.

## Query for Analog Voltage Input Level

### To query for analog voltage input level from non-isolated input:

1. Turn the 9-position mode control to the VAP position or press the rotary Adjust/Enter control if the mode control is already at the VAP position.  
*VAPr* is displayed on the output voltage display.
2. If the mode is currently *nonE* then select any other APG mode. If this step is done, be sure to restore the APG setting to *nonE* when the operation is complete. Otherwise, do not rotate the rotary Adjust/Enter control to keep the current APG mode.
3. Press the rotary Adjust/Enter control to select the APG mode.  
The output voltage display should read *LE U* and the output current display will display APG level.
4. Press the rotary Adjust/Enter control to return to normal mode.
5. If the APG mode was modified in step 2, execute the procedure to deactivate the APG voltage mode.

4

**Quick Tip** Remote operation uses these SCPI commands. See page 5-1.

### The SCPI commands for these instructions are:

```
[:]SYSTem[<channel>]:REMOte:SOURce[:VOLTage] <?|LOCAL|AVOLTage|IAVOLTage|ARESistive|IARESistive>
[:]SYSTem[<channel>]:COMMunicate:APROgram:LEVel[:VOLTage]
[:ISOLated]
[:]MEASure[<channel>][:SCALAR]:APROgram[:VOLTage][:DC]?
```

## Voltage-Controlled Current APG Setup

### Activating APG Current Mode

#### To activate APG current mode using an external voltage source:

1. Turn the 9-position mode control to the CAP position or press the rotary Adjust/Enter control if the mode control is already at the CAP position.  
 $\overline{CAP}$  is displayed on the output voltage display.
2. Turn the rotary Adjust/Enter control to select source  $Un IS$  (Voltage source from non-isolated connector).
3. Press the rotary Adjust/Enter control to commit the selected mode.  $\overline{LE}$  is displayed on the output voltage display.
4. Select the input source level using the rotary Adjust/Enter control.
5. Once the desired level has been selected, press the rotary Adjust/ Enter control to commit the change.  
The display will return to the normal display.

### Deactivating APG Current Mode

#### To deactivate the APG current mode:

1. Turn the 9-position mode control to the CAP position or press the rotary Adjust/Enter control if the mode control is already at the CAP position.
2.  $\overline{CAP}$  is displayed on the output voltage display.
3. Turn the rotary Adjust/Enter control to select  $nonE$ .
4. Press the rotary Adjust/Enter control to commit the change.  
The display will return to the normal display.

## Query for Analog Current Input Level

### To query for analog current input level from non-isolated input:

1. Turn the 9-position mode control to the CAP position or press the rotary Adjust/Enter control if the mode control is already at the CAP position.

`[APPr]` is displayed on the output voltage display.

2. If the mode is currently `nonE` then select any other APG mode. If this step is done, be sure to restore the APG setting to `nonE` when the operation is complete. Otherwise, do not rotate the rotary Adjust/ Enter control to keep the current APG mode.

3. Press the rotary Adjust/Enter control to select the APG mode.

The output voltage display should read `LE [ ]` and the output current display will display APG level.

4. Press the rotary Adjust/Enter control to return to normal mode.

5. If the APG mode was modified in step 2, execute the procedure to deactivate the APG voltage mode.

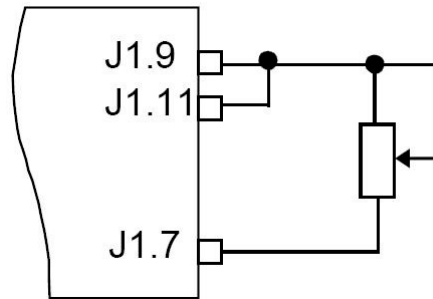
**Quick Tip Remote operation uses these SCPI commands. See page 5-1.**

### The SCPI commands for these instructions are:

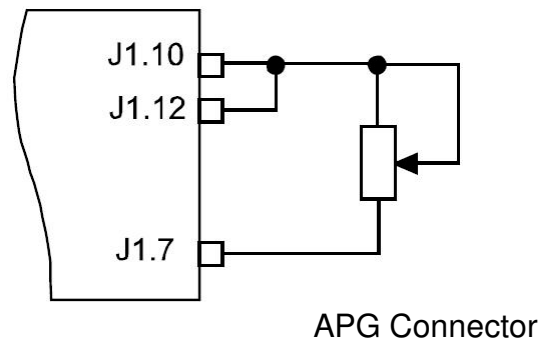
```
[:]SYSTem[<channel>]:REMOte:SOURce[:VOLtage] <?|LOCAl
|AVOLtage|IAVOLTage|ARESiStive|IAResistive>
[:]SYSTem[<channel>]:COMMunicate:APROgram:LEVel:CURRent
[:ISOLated]
[:]MEASure[<channel>][:SCALar]:APROgram:CURRent[:DC]?
```

### Analog Programming With External Resistor

The pin numbers are described in Table 4-3 on page 4-6.



**Figure 4-6** Programming Output Voltage using an External Resistor



**Figure 4-7** Programming Output Current using an External Resistor



## Resistive-Controlled Voltage APG Setup

### To activate APG voltage mode using an external resistor:

1. Turn the 9-position mode control to the VAP position or press the rotary Adjust/Enter control if the mode control is already at the VAP position.  
VAPr is displayed on the output voltage display.
2. Turn the rotary Adjust/Enter control to select rR (resistor source from non-isolated connector).
3. Press the rotary Adjust/Enter control to commit the selected mode. LE V is displayed on the output voltage display.
4. Select the input source level using the rotary Adjust/Enter control.
5. Once the desired level has been selected, press the rotary Adjust/Enter control to commit the change.  
The display will return to the normal display.

### Deactivating APG Voltage Mode

#### To deactivate the APG voltage mode:

1. Turn the 9-position mode control to the VAP position or press the rotary Adjust/Enter control if the mode control is already at the VAP position.
2. VAPr is displayed on the output voltage display.
3. Turn the rotary Adjust/Enter control to select nonE.
4. Press the rotary Adjust/Enter control to commit the change.  
The display will return to the normal display.

## Query for Analog Voltage Input Level

### To query for analog voltage input level from non-isolated input:

1. Turn the 9-position mode control to the VAP position or press the rotary Adjust/Enter control if the mode control is already at the VAP position.  
*VAPr* is displayed on the output voltage display.
2. If the mode is currently *nonE* then select any other APG mode. If this step is done, be sure to restore the APG setting to *nonE* when the operation is complete. Otherwise, do not rotate the rotary Adjust/Enter control to keep the current APG mode.
3. Press the rotary Adjust/Enter control to select the APG mode.  
The output voltage display should read *LE V* and the output current display will display APG level.
4. Press the rotary Adjust/Enter control to return to normal mode.
5. If the APG mode was modified in step 2, execute the procedure to deactivate the APG voltage mode.

**Quick Tip Remote operation uses these SCPI commands. See page 5-1.**

### The SCPI commands for these instructions are:

```
[:]SYSTem[<channel>]:REMOte:SOURce[:VOLtage] <?|LOCal|AVOLtage|IAVoltage|ARESistive|IAResistive>
[:]SYSTem[<channel>]:COMMunicate:APROgram:LEVel[:VOLtage]
[:ISOLated]
[:]MEASure[<channel>][:SCALar]:APROgram[:VOLtage][:DC]?
```

## Resistive-Controlled Current APG Setup

### To activate APG current mode using an external resistor source:

1. Turn the 9-position mode control to the CAP position to press the rotary Adjust/Enter control if the control knob is already at CAP position.  
CAP is displayed on the output voltage display.
2. Turn rotary Adjust/Enter control to select r n E (voltage source from non-isolated connector).
3. Press the rotary Adjust/Enter control to commit the selected mode. LE is displayed on the output voltage display.
4. Once the desired level has been selected, press the rotary Adjust/Enter control to commit the change.  
The display will return to the normal display.

## Deactivating APG Current Mode

### To deactivate the APG current mode:

1. Turn the 9-position mode control to the CAP position or press the rotary Adjust/Enter control if the mode control is already at the CAP position.
2. CAP is displayed on the output voltage display.
3. Turn the rotary Adjust/Enter control to select nonE.
4. Press the rotary Adjust/Enter control to commit the change.  
The display will return to the normal display.

## Query for Analog Current Input Level

### To query for analog current input level from non-isolated input:

1. Turn the 9-position mode control to the CAP position or press the rotary Adjust/Enter control if the mode control is already at the CAP position.  
`[APPr]` is displayed on the output voltage display.
2. If the mode is currently `nonE` then select any other APG mode. If this step is done, be sure to restore the APG setting to `nonE` when the operation is complete. Otherwise, do not rotate the rotary Adjust/ Enter control to keep the current APG mode.
3. Press the rotary Adjust/Enter control to select the APG mode.  
The output voltage display should read `LE [ ]` and the output current display will display APG level.
4. Press the rotary Adjust/Enter control to return to normal mode.
5. If the APG mode was modified in step 2, execute the procedure to deactivate the APG voltage mode.

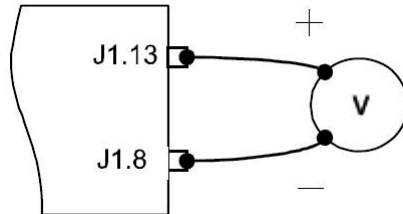
**Quick Tip Remote operation uses these SCPI commands. See page5-1.**

### The SCPI commands for these instructions are:

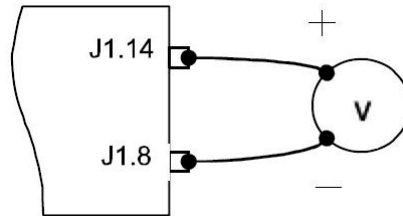
```
[:]SYSTem[<channel>]:REMOte:SOURce:CURRent <?|LOCAl  
|AVOLtage|IAVOLTage|ARESiStive|IAResistive>  
[:]SYSTem[<channel>]:COMMunicate:APROgram:LEVel:CURRent  
[:ISOLated]  
[:]MEASure[<channel>][:SCALAr]:APROgram:CURRent[:DC]?
```

## Voltage and Current Readback

The pin numbers are described in Table 4-3 on page 4-6.



**Figure 4-8** Voltage Readback Using APG Connector J1



**Figure 4-9** Current Readback Using APG Connector J1

## Isolated Analog Programming Mode (ISOL)

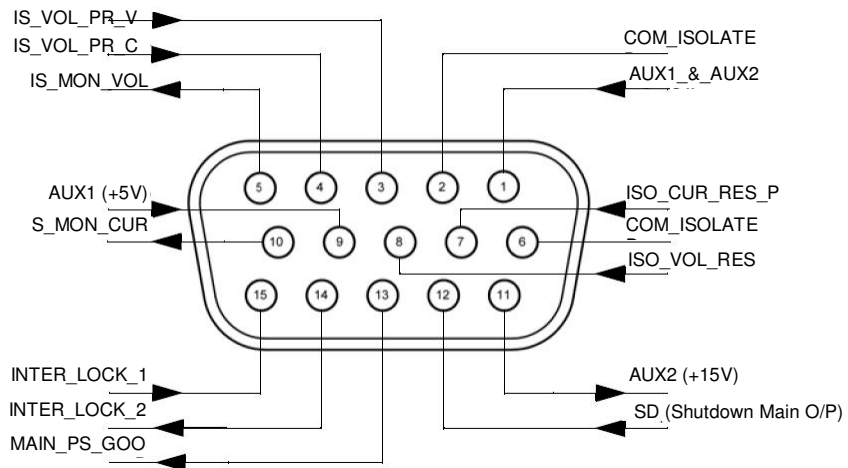
See “Rear Panel Connectors on 850 Watt Models” on page 1-7 “Rear Panel Connectors on 1500 and 1700 Watt Models” on page 1-9 for more details about connections.

### AUX Output and Isolated Analog Programming (ISOL) Connector

The AUX Output and Isolated Analog Programming (ISOL) Connector is a 15-pin female DSUB connector. See Figure 4-10. All pins on this connector are electrically isolated from the output of the power supply.

The AUX Output and ISOL Connector provides access to the following functions:

Function	XG/XTR1500 and 1700	XG/XTR850
Auxiliary +5 V and +15 V outputs	standard	standard
OUTPUT ENABLE Aux	standard	standard
Power On Status (output)	optional	standard
SD—Shutdown (input)	optional	standard
Interlock	optional	standard
ISOL programming and monitoring	optional	standard



**Figure 4-10** AUX Output and ISOL Connector Pinout

**Table 4-4** AUX Output and ISOL Connector Pins and Functions J3

Pin	Reference	Function
J3.1	AUX_ON_OFF	Auxiliary enable/disable
J3.2	COM_ISOLATED	Isolated Common (Isolated from Main Output and Communication. Return wire for +5 V, +15 V Auxiliary Voltage.
J3.3	IS_VOL_PR_VOL	Isolated Analog Voltage Programming Input
J3.4	IS_VOL_PR_CUR	Isolated Analog Current Programming Input
J3.5	IS_MON_VOL <sup>1</sup>	Isolated Voltage Monitor. Scaled to the value of the Voltage Analog Programming Level.
J3.6	COM_ISOLATED	Isolated Common (Isolated from Main Output and Communication. Return wire for control signals, monitoring and programming.
J3.7	ISO_CUR_RES_PR	Isolated Current Resistive Programming
J3.8	ISO_VOL_RES_PR	Isolated Voltage Resistive Programming
J3.9	+AUX 1 <sup>2</sup>	+5 V Isolated Output
J3.10	IS_MON_CUR <sup>1</sup>	Isolated Current Monitor. Scaled to the value of the Voltage Analog Programming Level.
J3.11	+AUX 2 <sup>2</sup>	+15 V Isolated Output
J3.12	SD	Shutdown. Input to power supply to disable output. This input has user selectable negative logic operation via front panel or remote digital input/output.
J3.13	PS_GOOD	PS_GOOD. Power supply output enabled.
J3.14	INTER_LOCK 1	Interlock. Dry contact type. Shorting pins J3.14 and J3.15 while the interlock functionality is enabled, will enable the output of the power supply.
J3.15	INTER_LOCK 2	Interlock

1. Important: Isolated monitor lines are only valid when Isolated analog programming modes are used for the respective voltage and current control. If local control, digital control or non-isolated APG is used, the non-isolated monitor lines should be used as the isolated monitor lines will not accurately reflect the output state of the power supply.
2. Use unshielded cable up to 9.84 feet (3 m) length with high-density D-Sub type connector and a ferrite bead (Fair-Rite part number 0443164251).



**CAUTION: Equipment damage**

Do not drive or apply a voltage to pins J3.14 (Inter\_Lock 1) or to pins J3.15 (Inter\_Lock 2).

## Making ISOL Control Connections



### CAUTION: Equipment damage

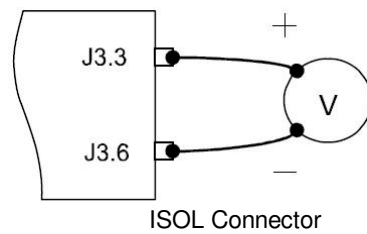
Before making connections from external circuits to the Isolated Analog Programming Connector, turn the front panel power switch to off and wait until the front panel displays have gone out.

---

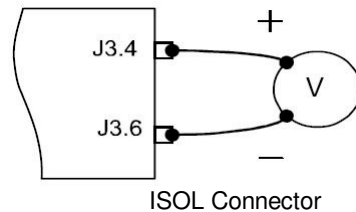
For most connectors and jumpers, use any suitable wire such as 22 AWG stranded wire. For lowest noise performance, use shielded twisted pair wiring of 22 AWG. Use the shortest leads possible. +5 V and +15 V Auxiliary Output reference to pin 2 and 6 (isolated common) on the ISOL Connector.

## ISOL Programming With External Voltage Source

The pin numbers are described in Table 4-4 on page 4-21.



**Figure 4-11** Programming Output Voltage using an Isolated External Voltage Source



**Figure 4-12** Programming Output Current using an Isolated External Voltage Source



## Voltage-Controlled Voltage ISOL Setup

### Activating ISOL Programming Voltage Mode

**To activate ISOL programming voltage mode with an external voltage source:**

1. Turn the 9-position mode control to the VAP position or press the rotary Adjust/Enter control if the mode control is already at the VAP position.  
*VAP* is displayed on the output voltage display.
2. Turn rotary Adjust/Enter control to select *V I 5* (voltage source from isolated connector).
3. Press the rotary Adjust/Enter control to commit the selected mode. *LE V* is displayed on the output voltage display.
4. Select the input source level using the rotary Adjust/Enter control.
5. Once the desired level has been selected, press the rotary Adjust/ Enter control to commit the change.  
The display will return to the normal display.

### Deactivating ISOL Voltage Mode

**To deactivate the ISOL voltage mode:**

1. Turn the 9-position mode control to the VAP position or press the rotary Adjust/Enter control if the mode control is already at the VAP position.
2. *VAP* is displayed on the output voltage display.
3. Turn the rotary Adjust/Enter control to select *none*.
4. Press the rotary Adjust/Enter control to commit the change.  
The display will return to the normal display.

## Query for ISOL Voltage Input Level

### To query for ISOL voltage input level from non-isolated input:

1. Turn the 9-position mode control to the VAP position or press the rotary Adjust/Enter control if the control knob is already at the VAP position.  
*VAPr* is displayed on the output voltage display.
2. If the mode is currently *nonE* then select any other ISOL mode. If this step is done, be sure to restore the ISOL setting to *nonE* when the operation is complete. Otherwise, do not rotate the rotary Adjust/Enter control to keep the current ISOL mode.
3. Press the rotary Adjust/Enter control to select the ISOL mode.  
The output voltage display should read *LE U* and the output current display will display ISOL level.
4. Press the rotary Adjust/Enter control to return to normal mode.
5. If the ISOL mode was modified in step 2, execute the procedure to deactivate the ISOL voltage mode.

**Quick Tip Remote operation uses these SCPI commands. See page 5-1.**

### The SCPI command for these instructions are:

```
[:]SYSTem[<channel>]:REMOte:SOURce[:VOLTage] <?|LOCAL|AVOLTage|IAVOLTage|ARESistive|IARESistive>
[:]SYSTem[<channel>]:COMMunicate:APROgram:LEVel[:VOLTage][:ISOLated]
[:]MEASure[<channel>][:SCALAR]:APROgram[:VOLTage]:ISOLated[:DC]?
```

## Voltage-Controlled Current ISOL Setup

### Activating ISOL Programming Current Mode

1. Turn the 9-position mode control to the CAP position or press the rotary adjust/Enter control if the control knob is already at the CAP position.  
 $[\overline{CAP}]$  is displayed on the output voltage display.
2. Turn the rotary Adjust/Enter control to select  $U I S$  (voltage source from isolated connector).
3. Press the rotary adjust/Enter control to commit the selected mode.  $LE \overline{U}$  is displayed on the output voltage display.
4. Select the input source level using the rotary adjust/Enter control.
5. Once the desired level has been selected, press the rotary adjust/ Enter control to commit the change.  
The display will return to the normal display.

### Deactivating ISOL Current Mode

#### To deactivate the ISOL current mode:

1. Turn the 9-position mode control to the VAP position or press the rotary Adjust/Enter control if the control knob is already at the VAP position.
2.  $[\overline{CAP}]$  is displayed on the output voltage display.
3. Turn the rotary Adjust/Enter control to select  $nonE$ .
4. Press the rotary Adjust/Enter control to commit the change.  
The display will return to the normal display.

## Query for ISOL Current Input Level

### To query for ISOL current input level from non-isolated input:

1. Turn the 9-position mode control to the CAP position or press the rotary Adjust/Enter control if the control knob is already at the CAP position.  
[APPr] is displayed on the output voltage display.
2. If the mode is currently none then select any other ISOL mode. If this step is done, be sure to restore the ISOL setting to none when the operation is complete. Otherwise, do not rotate the rotary Adjust/Enter control to keep the current ISOL mode.
3. Press the rotary adjust/Enter control to select the ISOL mode.  
The output voltage display should read LE [ ] and the output current display will display ISOL level.
4. Press the rotary adjust/Enter control to return to normal mode.
5. If the ISOL mode was modified in step 2, execute the procedure to deactivate the ISOL voltage mode.

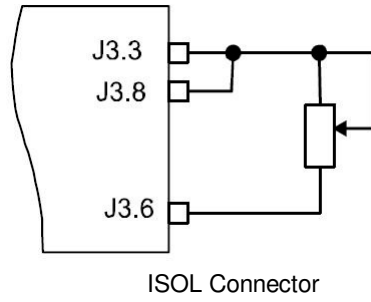
**Quick Tip Remote operation uses these SCPI commands. See page 5-1.**

### The SCPI command for these instructions are:

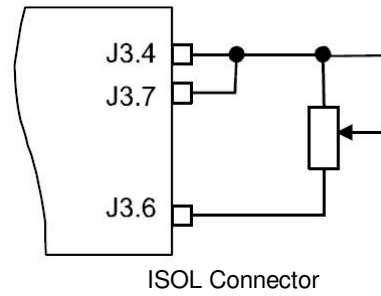
```
[:]SYSTem[<channel>]:REMOte:SOURce:CURRent: <?|LOCAL|AVOLTage|IAVOLTage|ARESiStive|IAResistive>
[:]SYSTem[<channel>]:COMMunicate:APROgram:LEVel:CURRent[:ISOLated]
[:]MEASure[<channel>][:SCALar]:APROgram:CURRent[:ISOLated[:DC]?]
```

### Analog Programming With External Resistor

The pin numbers are described in Table 4-4 on page 4-21.



**Figure 4-13** Programming Output Voltage using an Isolated External Resistor



**Figure 4-14** Programming Output Current using an Isolated External Resistor

## Resistive-Controlled Voltage ISOL Setup

### Activating ISOL Programming Voltage Mode

**To activate ISOL programming voltage mode using an external resistor:**

1. Turn the 9-position mode control to the VAP position or press the rotary adjust/Enter control if the control knob is already at the VAP position.  
*VAPr* is displayed on the output voltage display.
2. Turn the rotary Adjust/Enter control to select *r 5* (resistor source from isolated connector).
3. Press the rotary adjust/Enter control to commit the selected mode. *LE V* is displayed on the output voltage display.
4. Select the input source level using the rotary adjust/Enter control.
5. Once the desired level has been selected, press the rotary Adjust/ Enter control to commit the change.  
The display will return to the normal display.

### Deactivating ISOL Voltage Mode

**To deactivate the ISOL voltage mode:**

1. Turn the 9-position mode control to the VAP position or press the rotary Adjust/Enter control if the control knob is already at the VAP position.
2. *VAPr* is displayed on the output voltage display.
3. Turn the rotary Adjust/Enter control to select *nonE*.
4. Press the rotary adjust/Enter control to commit the change.  
The display will return to the normal display.

## Query for ISOL Voltage Input Level

### To query for ISOL voltage input level from non-isolated input:

1. Turn the 9-position mode control to the VAP position or press the rotary Adjust/Enter control if the control knob is already at the VAP position.  
*VAPr* is displayed on the output voltage display.
2. If the mode is currently *nonE* then select any other ISOL mode. If this step is done, be sure to restore the ISOL setting to *nonE* when the operation is complete. Otherwise, do not rotate the rotary Adjust/Enter control to keep the current ISOL mode.
3. Press the rotary adjust/Enter control to select the ISOL mode.  
 The output voltage display should read *LE U* and the output current display will display ISOL level.
4. Press the rotary adjust/Enter control to return to normal mode.
5. If the ISOL mode was modified in step 2, execute the procedure to deactivate the ISOL voltage mode.

**Quick Tip** Remote operation uses these SCPI commands. See page 5-1.

### The SCPI command for these instructions are:

```
[:]SYSTem[<channel>]:REMOte:SOURce[:VOLTage] <?|LOCAL|AVOLTage|IAVoltage|ARESistive|IAResistive>
[:]SYSTem[<channel>]:COMMunicate:APROgram:LEVel[:VOLTage][:ISOLated]
[:]MEASure[<channel>][:SCALAR]:APROgram[:VOLTage]:ISOLated[:DC]?
```

## Resistive-Controlled Current ISOL Setup

### Activating ISOL Resistive-Controlled Current Setup

1. Turn the 9-position mode control to the CAP position or press the rotary Adjust/Enter control if the control knob is already at the CAP position.  
CAP is displayed on the output voltage display.
2. Turn rotary Adjust/Enter control to select  $r \ 5$  (voltage source from isolated connector).
3. Press the rotary Adjust/Enter control to commit the selected mode. LE is displayed on the output voltage display.
4. Select the input source level using the rotary Adjust/Enter control.
5. Once the desired level has been selected, press the rotary Adjust/ Enter control to commit the change.  
The display will return to the normal display.

### Deactivating ISOL Current Mode

#### To deactivate the ISOL current mode:

1. Turn the 9-position mode control to the CAP position or press the rotary Adjust/Enter control if the control knob is already at the CAP position.
2. CAP is displayed on the output voltage display.
3. Turn the rotary Adjust/Enter control to select  $nmE$ .
4. Press the rotary Adjust/Enter control to commit the change.  
The display will return to the normal display.



## Query for ISOL Current Input Level

### To query for ISOL current input level from non-isolated input:

1. Turn the 9-position mode control to the CAP position or press the rotary Adjust/Enter control if the control knob is already at the CAP position.  
 $[APPr]$  is displayed on the output voltage display.
2. If the mode is currently  $nonE$  then select any other ISOL mode. If this step is done, be sure to restore the ISOL setting to  $nonE$  when the operation is complete. Otherwise, do not rotate the rotary Adjust/Enter control to keep the current ISOL mode.
3. Press the rotary Adjust/Enter control to select the ISOL mode.  
 The output voltage display should read  $LE [ ]$  and the output current display will display ISOL level.
4. Press the rotary Adjust/Enter control to return to normal mode.
5. If the ISOL mode was modified in step 2, execute the procedure to deactivate the ISOL voltage mode.

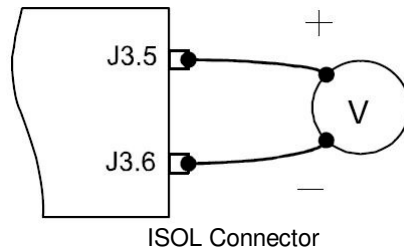
**Quick Tip** Remote operation uses these SCPI commands. See page 5-1.

### The SCPI command for these instructions are:

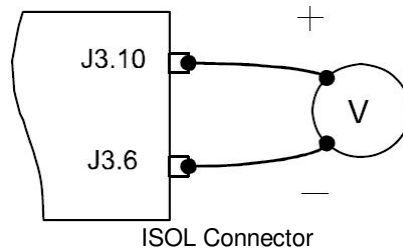
```
[:]SYSTem[<channel>]:REMOte:SOURce:CURRent <?|LOCAl|AVOLtage|IAVOLTage|ARESiStive|IAResistive>
[:]SYSTem[<channel>]:COMMunicate:APROgram:LEVel:CURRent[:ISOLated]
[:]MEASure[<channel>][:SCALar]:APROgram:CURRent[:ISOLated[:DC]?]
```

## Voltage and Current Readback (Isolated)

The pin numbers are described in Table 4-4 on page 4-21.



**Figure 4-15** Isolated Voltage Monitoring



**Figure 4-16** Isolated Current Monitoring

### Query Remote Control Source State

**Quick Tip** Remote operation uses these SCPI commands. See page 5-1.

**The SCPI command for these instructions are:**

```
[ : ] SYSTem[ <channel> ] : REMote : SOURce [ : VOLTage ] ?  
[ : ] SYSTem[ <channel> ] : REMote : SOURce : CURRent ?
```

# 5

## Remote Operation

Chapter 5, Remote Operation, describes the remote operation of the XG/XTR power supply via the communication ports.

## Introduction

In addition to the front panel interface, the XG/XTR can be remotely controlled through the various remote interfaces. The XG/XTR implements the SCPI standard as its command line interface for remotely controlling the power supply. Additionally, a small subset of legacy commands has been provided for ease of use and backwards compatibility. All of the remote interfaces use the same command line interface.

This chapter is divided into two parts:

- Hardware and Connection Setup provides information on how to setup a connection to the different remote interfaces available on the XG/XTR. The remote interfaces covered include RS-232, RS-485, USB, and GPIB. (The LAN/ENET option is set up differently between the XG/XTR 850 Watt models and the 1500 and 1700 Watt models. See either **SETTING UP XG/XTR 850 WATT MODELS** or **SETTING UP XG/XTR 1500 and 1700 WATT MODELS** in Section 6 “*Communications Options*”, as applicable).
- Command Line Interface and SCPI explains how to send commands to the power supply using the SCPI commands and the theory behind SCPI.

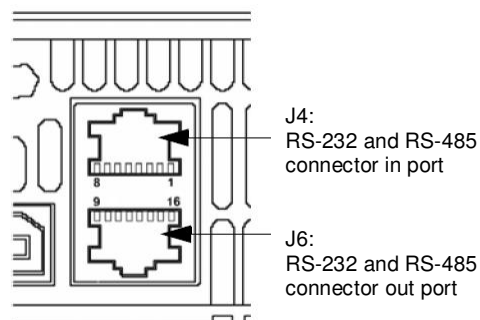
## Hardware and Connection Setup

This section provides information on setting up the hardware and is organized into setup for each hardware type. Once the setup has been successfully completed, data can be sent to and responses received from the power supply. Select which hardware interface to use and follow the instructions and diagram for that hardware set up.

### Configuring Remote Control Using RS-232

To configure remote control using RS-232:

1. Use the top J4 connector of the two 8-pin RJ-45 jacks, as shown in Figure 5-1, to connect to the RS-232 remote interface.
2. Connect from PC to power supply using a cable that meets the cabling specifications listed in Table 5-1.



**Figure 5-1** Remote Control Connectors

**Table 5-1** Remote Control Connector Pins and Functions J4 and J6<sup>1</sup>

Pin	Reference	Direction	Function
J4.1	RX-232	Input	RS-232
J4.2	TX-232	Output	RS-232
J4.3	RXD+	Input	RS-485 receiving
J4.4	RXD-	Input	RS-485 receiving
J4.5	TXD+	Output	RS-485 transmitting
J4.6	TXD-	Output	RS-485 transmitting
J4.7	GND	–	Ground
J4.8	NC	–	–
J6.9	NC	–	–
J6.10	NC	–	–
J6.11	RXD+	Input	RS-485 receiving
J6.12	RXD-	Input	RS-485 receiving
J6.13	TXD+	Output	RS-485 transmitting
J6.14	TXD-	Output	RS-485 transmitting
J6.15	GND	–	Ground
J6.16	NC	–	–

1. All references and directions indicated in this table are with respect to the XG/XTR.

**RS-232 Communication Cable with RJ-45 to DB-9**

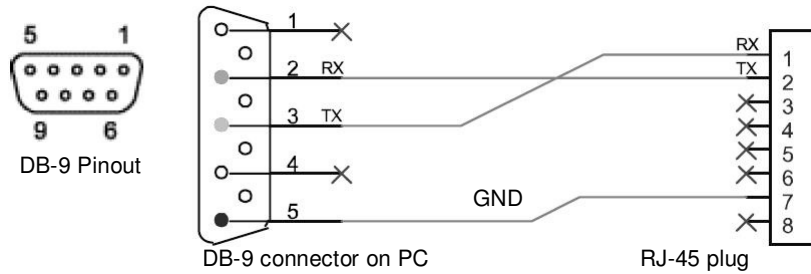
Communication control cable with DB-9 connector (male) on the PC side and RJ-45 shielded connector on the power supply. The cable length should be 9.84 feet (3 m) or longer.

**Table 5-2** DB-9 Pinouts

Pin	Name	Description
1	NC	No connection
2	RX	Receive data
3	TX	Transmit data
4	NC	No connection
5	GND	Ground
6, 7, 8, 9	NC	No connection

**Table 5-3** RJ-45 Pinouts

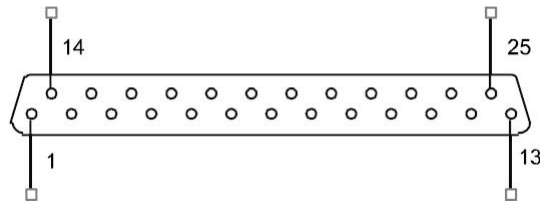
Pin	Name	Description
1	RX	Receive data
2	TX	Transmit data
3, 4, 5, 6	NC	No connection
7	GND	Ground
8	NC	No connection



**Figure 5-2** RS-232 Communication Cable with DB-9 Pinout

**RS-232 Communication Cable with RJ-45 to DB-25**

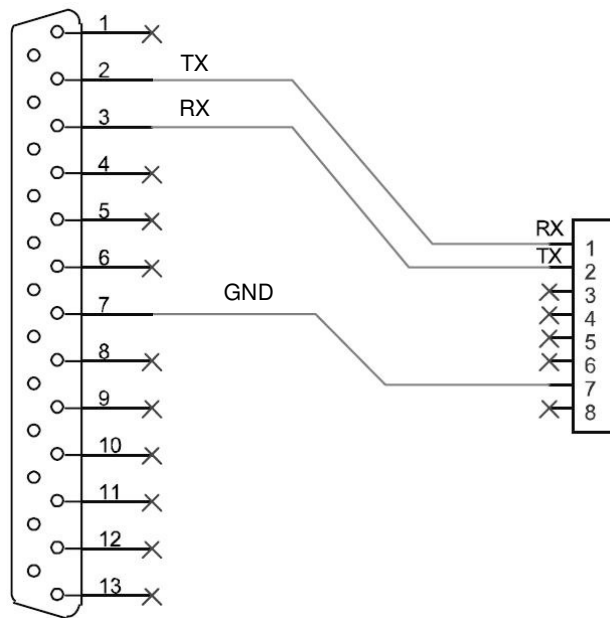
Communication control cable with DB-25 pinout (male) on the PC side and RJ-45 shielded connector on the power supply. The cable length should be 9.84 feet (3 m) or longer.



**Figure 5-3** DB-25 Pinout

**Table 5-4** DB-25 Pinouts

Pin	Name	Description
1	NC	No connection
2	TX	Receive data
3	RX	Transmit data
4, 5, 6	NC	No connection
7	GND	Ground
8, 9	NC	No connection



**Figure 5-4** RS-232 Communication Cable with DB-25 Pinout

### Completing the Setup

**To complete the setup:**

- ◆ Configure the XG/XTR to use the 232 remote interface and set up the terminal that will be used on the connected PC.  
See the sections entitled "Selecting the Appropriate Communication Port" on page 5-24 and "Terminal Configuration" on page 5-21 for more details.



## Configuring Remote Control Using RS-485

### RS-485 Communication Cable with RJ-45 to DB-9

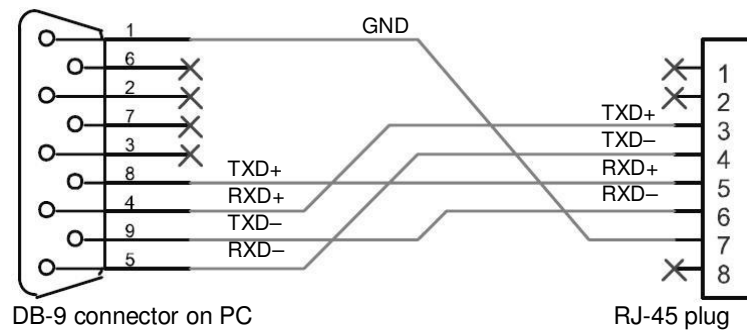
Communication control cable with DB-9 pinout (female) on the PC side (see Figure 5-2) and RJ-45 shielded connector on the power supply.

**Table 5-5** DB-9 Pinouts

Pin	Name	Description	
1	GND	Ground	
2, 3	NC	No connection	
4	RXD+	Receive data	Twisted pair
5	RXD-	Transmit data	
6, 7	NC	No connection	
8	TXD+	Transmit data	Twisted pair
9	TXD-	Transmit data	

**Table 5-6** RJ-45 Plug Pinouts

Pin	Name	Description	
1, 2	NC	No connection	
3	TXD+	Transmit data	Twisted pair
4	TXD-	Transmit data	
5	RXD+	Receive data	Twisted pair
6	RXD-	Receive data	
7	GND	Ground	
8	NC	No connection	



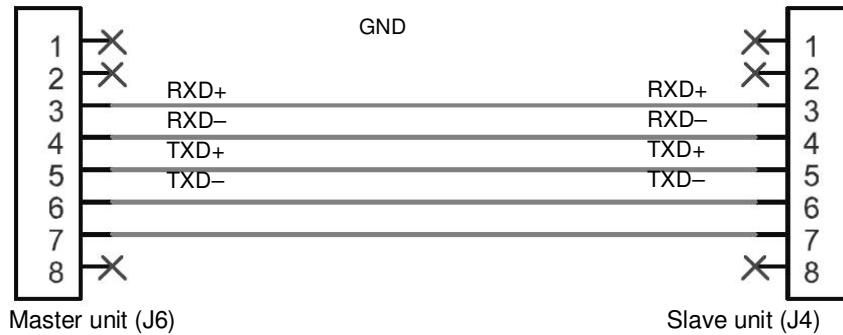
**Figure 5-5** RS-485 Communication Cable with DB-9

### RS-485 Communication Cable with Two RJ-45s

Use the top connector of the two 8-pin RJ-45 jacks, as shown in Figure 5-1, to connect to the RS-485 remote interface. Communication cable with two RJ-45 shielded connectors (see Figure 5-3) connecting the master unit to the slave unit. The cable length should be 9.84 feet (3 m) or longer. The pinouts for the RJ-45 plug on the master unit are the same as described in Table 5-7.

**Table 5-7** RJ-45 Plug on Slave Unit

Pin	Name	Description
1, 2	NC	No connection
3	RXD+	Receive data
4	RXD-	Receive data
5	TXD+	Transmit data
6	TXD-	Transmit data
7	GND	Ground
8	NC	No connection



**Figure 5-6** RS-485 Communication Cable from Master to Slave Unit

### Completing the Setup

**To complete the setup:**

- ◆ Configure the XG/XTR to use the 485 remote interface and setup the terminal that will be used on the connected PC.

See sections entitled “Selecting the Appropriate Communication Port” on page 5-24 and “Terminal Configuration” on page 5-21 for more details.

## Configuring Remote Control using the USB Connector

The power supply can be controlled from a remote terminal using a USB interface. The standard USB connector is located on the rear panel of both the XG/XTR 850 Watt model, as shown in Figure 1-3 on page 1-7 and the XG/XTR 1500 and 1700 Watt models, as shown in Figure 1-6 on page 1-9. Use a standard USB shielded cable up to 9.84 feet (3 m) in length.

## Setting Up the PC to Use the USB Connection

### Installing USB to Serial Converter and Serial Port

To set up the USB connection, you'll need to download the latest driver from Future Technology Devices International Ltd. or from [www.programmablepower.com](http://www.programmablepower.com).

#### To download and install a virtual COM port (VCP) driver:

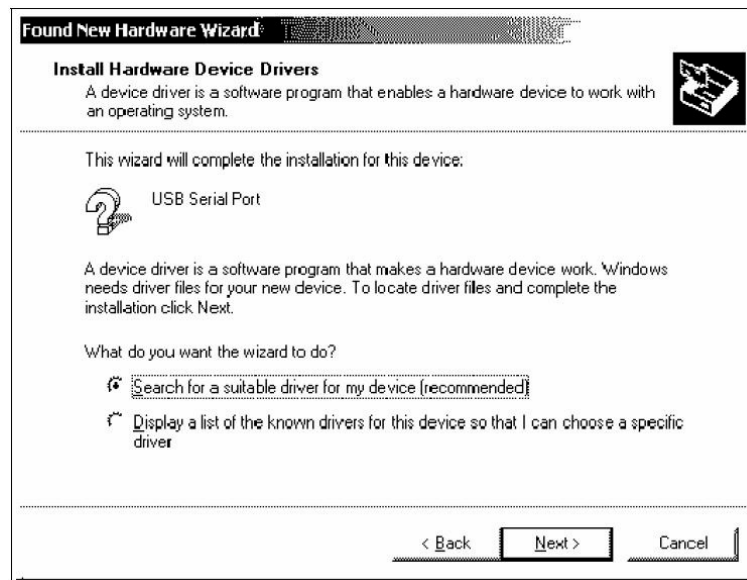
1. Go to [www.programmablepower.com](http://www.programmablepower.com) and navigate to the XG/XTR product web page.
2. Click the download link to download the driver.
3. Download the appropriate virtual COM port (VCP) drivers for your operating system (with enhanced BM series support).
4. Create a folder C:\FTDI.
5. Unzip files from the archive into this folder.
6. Connect your device to a spare USB port on your computer.

The Found New Hardware Wizard automatically launches, as shown in Figure 5-7.



**Figure 5-7** Found New Hardware Wizard

7. Click Next.
8. On the Install Hardware Device Driver screen, select “Search for a suitable driver for my device (recommended)” and click Next. See Figure 5-8.



**Figure 5-8** Install Hardware Device Drivers

9. In the Locate Driver Files dialog box, in the field Optional Search Locations, select Specify A Location and click Next.
10. On the next screen, enter the file path “C:\FTDI” and click OK.
11. On the next screen, select “Driver Files Search Results” and click Next.
12. In Completing the Found New Hardware Wizard, see Figure 5-9, click Finish to complete the installation.



**Figure 5-9** Completing the New Hardware Wizard

This completes the first part of the installation during which the USB to serial converter is installed. The second part involves the installation of a serial port, which should follow automatically once the converter installation is complete. Installation of the serial port does not require any user intervention.

### Verifying Installation

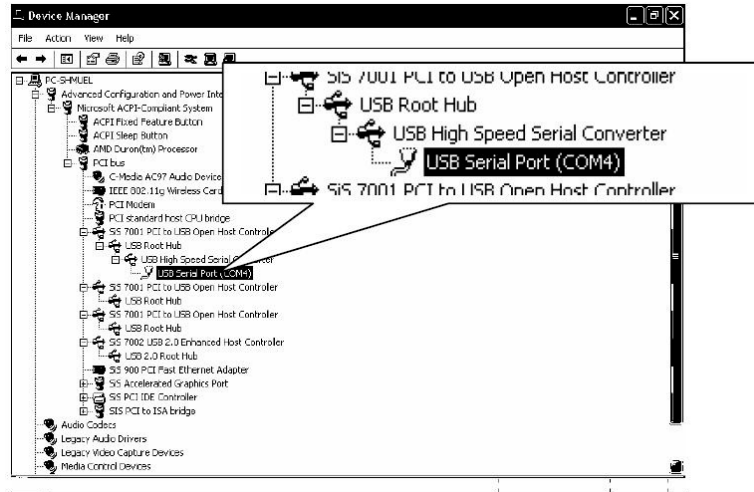
Once the installation of the serial port has completed, verify that the installation has been successful by looking under Device Manager of the System Properties screen. The device should have installed as a USB Serial Port (COMx) attached to USB High Speed Serial Converter.

**To verify that the device has been installed:**

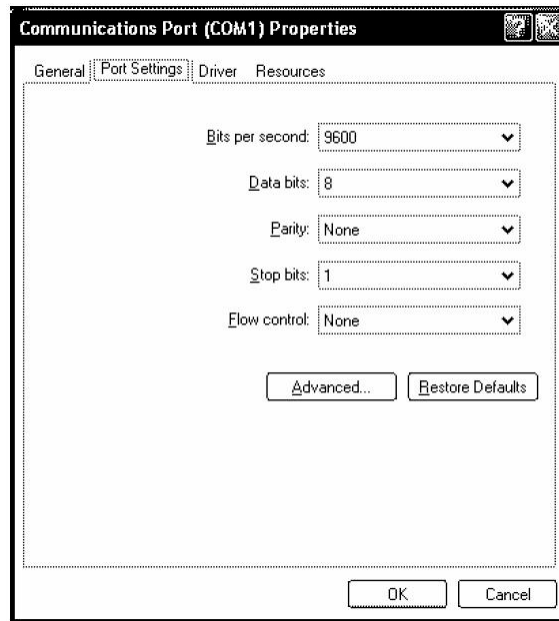
1. In Control Panel, go to System, click the Hardware tab and click on Device Manager.
2. On the View menu, select Devices by Type.
3. To change the virtual COM port properties, select the USB Serial Port and then Click Properties.

This allows you to change serial port properties such as data rate (bps) and data bits. You are also able to change the COM port which is assigned to your device.

4. Click the Port Settings tab, then click Advanced.

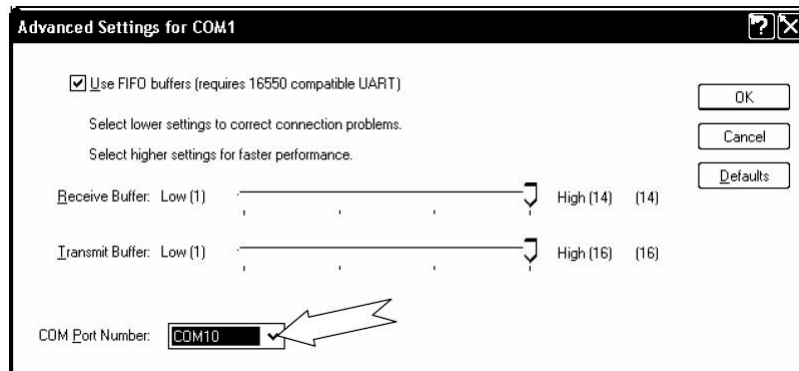


**Figure 5-10** Device Manager



**Figure 5-11** Communications Port (COM1) Properties

- In the COM port list, scroll to the required COM port.



**Figure 5-12** Completing the new hardware wizard

- Click OK.  
Ensure that you do not select a COM port which is already in use. This selection is particularly useful for programs, such as HyperTerminal, which only work with COM1 through to COM4.

## Complete the Setup

### To complete the setup:

- ◆ Configure the XG/XTR to use the USB remote interface and set up the terminal that will be used on the connected PC.

See “Selecting the Appropriate Communication Port” on page 5-24 and “Terminal Configuration” on page 5-21 for more details.



## GPIB Connector (Optional)

The power supply can be programmed from a remote terminal using a General Purpose Interface Bus (GPIB interface)

The GPIB interface is an 8-bit parallel data bus having a host of bus commands for synchronization and up to one megabyte data transfer rate. Use standard IEEE-486, 26 AWG GPIB cable up to 3 m length.

### GPIB Pin Description

The GPIB port is a 21-pin, special GPIB female connector. Table 5-8 identifies the pin names and describes the pin functions.

**Table 5-8** GPIB Pin Description (J2)

Pin #	Name	Function	Note
1	DIO1	DIO1	Data
2	DIO2	DIO2	Data
3	DIO3	DIO3	Data
4	DIO4	DIO4	Data
5	EOI	End of Identify	Control
6	DAV	Data Valid	Handshake
7	NRFD	Not Ready for Data	Handshake
8	NDAC	No Data Accepted	Handshake
9	IFC	Interface Clear	Control
10	SRQ	Service Request	Control
11	ATN	Attention	Control
12	-	Shield	Chassis
13	DIO5	DIO5	Data
14	DIO6	DIO6	Data
15	DIO7	DIO7	Data
16	DIO8	DIO8	Data
17	REN	Remote Enable	Control
18	-	DAV Return	Chassis
19	-	NRFD Return	Chassis
20	-	NDAC Return	Chassis
21	-	IFC Return	Chassis
22	-	SRQ Return	Chassis
23	-	ATN Return	Chassis
24	-	Signal Ground	Chassis

## Communication with Your Device

This section provides information on selecting the GPIB interface as the communication port used on the XTR, and it also provides an example of how commands can be sent and received. The details of the IEEE 488.2 and SCPI status reporting register structures and a complete list of commands available can be found later in this section.

### Selecting a Communication Port

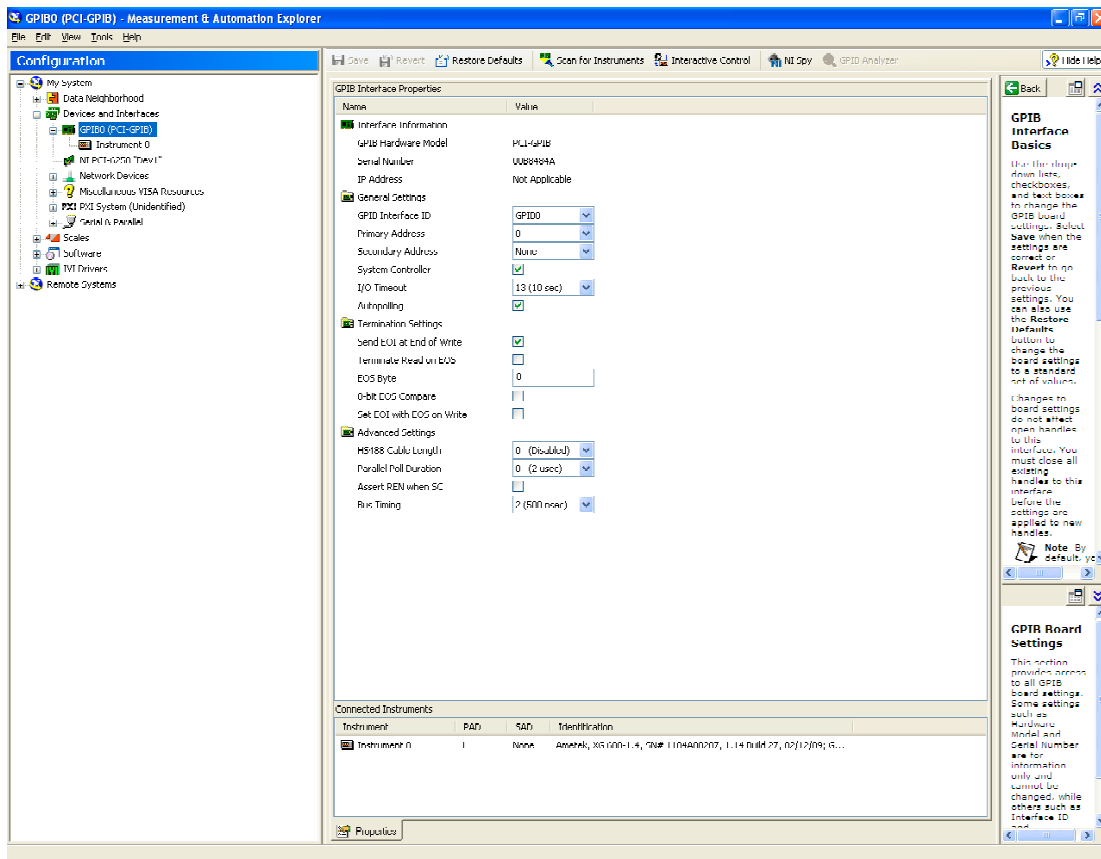
#### To select the GPIB as the communication port:

1. Turn the 9-position Mode control to PGM.  
*rE* is displayed in the output voltage display.
2. Turn the rotary Adjust/Enter control to select the 6PIb communication port.
3. Press the rotary Adjust/Enter control.  
*Addr* is displayed on the output voltage display.
4. Turn the rotary Adjust/Enter control to select the desired address between 1 to 30. For the purpose of this example, 10 will be selected.
5. Press the rotary Adjust/Enter control to commit the new address.
6. Click Scan For Instruments on the GPIB Explorer toolbar so that the power supply will be found (see Figure 5-13).

---

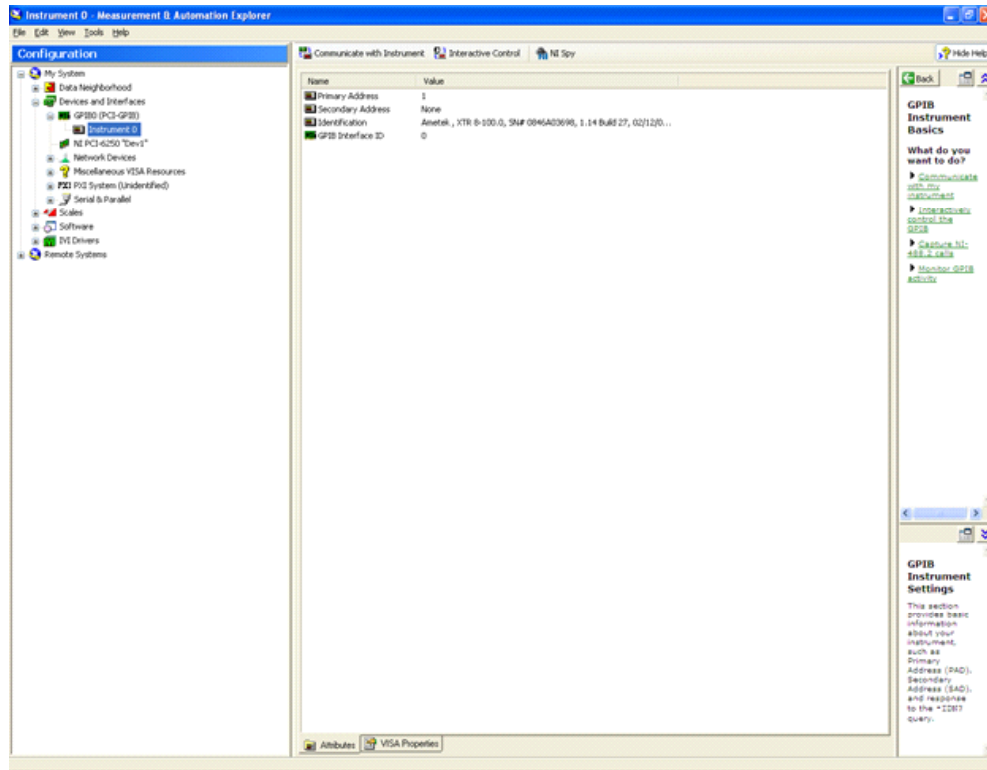
**Important:** This section uses the National Instruments™ MAX program to communicate with the XTR. This is for demonstration purposes only. Any software that is capable of addressing a GPIB device and sending and receiving text could be used in its place. Consult your GPIB card manufacturer to see if they provide an equivalent program.

---



**Figure 5-13** Scanning for Instruments

7. In the right window, click on Instrument 0 and review the device properties. See Figure 5-14.



**Figure 5-14** Instrument Properties

8. Click **Communicate with Instrument** in the GPIB Explorer toolbar. See Figure 1-3.  
NI-488.2 Communicator appears.
9. In the **Send String** box of the NI-488.2 Communicator window, type `*IDN?` and click the **Query** button.

---

**Important:** If you press **Enter** while typing the string to be sent, the NI-488.2 Communicator program will exit.

---

10. The **String Received** window in the lower half of the NI-488.2 Communicator window will show the ID string for the instrument.

The ID string indicates the model, serial number, firmware version as well as the GPIB card firmware version.

## Ethernet/LAN (ENET) Connector (Optional)

The power supply also can be programmed from a remote terminal using the Ethernet (ENET). If your power supply is configured with the Ethernet option, set-up instructions differ between the 850 Watt models and the 1500 and 1700 Watt models.

For the **XG/XTR 850 Watt** power supply with the MEA option, see **SETTING UP XG/XTR 850 WATT MODELS** in Section 6 “Communications Options” of this manual).

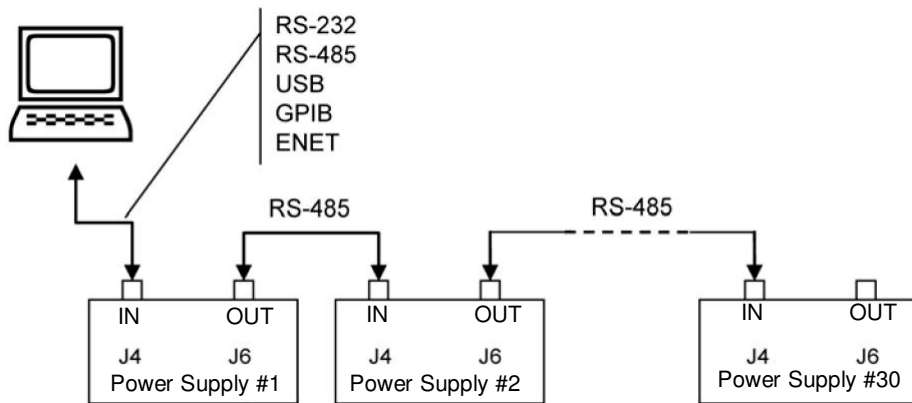
For the **XG/XTR 1500 and 1700 Watt** power supplies with the MEB option, see **SETTING UP XG/XTR 1500 and 1700 WATT MODELS** in Section 6 “Communications Options” of this manual.

For connecting the power supply to ENET, use a LAN RJ-45 and RJ-45 STP. Use a standard RJ-45 and RJ-45 cross-cable, Cat 5.

## Multiple Power Supply Connections to RS-485 Bus

Up to 30 units may be connected to the RS-485 bus. The first unit (master unit) connects to the controller via any appropriate port, and the other units (slave units) are connected with the RS-485 bus via the J6 connector. All units connected together should also have unique multichannel addresses.

A standard straight-through RJ-45 Ethernet network cable can be used to provide the connection between the power supplies. See Figure 5-13.



**Figure 5-13** Multi Power Supply Connection to RS-485 Bus

## Multiple Power Supply Setup

### Master Setup:

- ◆ Configure the master XG/XTR by selecting the communication interface you wish to use to communication with the Master and follow the setup instruction in this chapter.

---

**Important:** If either RS-232 or RS-485 are used for communication with the master, the data rate must be configured for 9600 bps to properly communicate with the slave units.

---

### Slave Setup:

1. Turn the 9-position mode control to PGM.  
rEl is displayed in the output voltage display.
2. Turn the rotary Adjust/Enter control to select  $\overline{hAn}$  and press the control to enter the setting.
3. Set a unique address. See “Multichannel Address Setting” on page 5-25.

---

## Terminal Configuration

The terminal program allows serial communication with the power supply. To use a terminal program, set it up using the parameters from the following sections. If you wish to use HyperTerminal, see “HyperTerminal” on page 5-21 for instructions setting it up.

### Data Format

Serial data format is 8 bit, one stop bit. No parity bit. Flow control: none.

### End of Message

The end of message is the Carriage Return character (ASCII 13, 0x0D). The power supply ignores the Line Feed (ASCII 10, 0x0A) character.

### HyperTerminal

The HyperTerminal program is a standard windows program and can be found in **Start >All Programs >Accessories >Communications >Hyper Terminal**.

#### Setting up a HyperTerminal connection

##### To set up a HyperTerminal connection:

1. When HyperTerminal opens, it will immediately enter the New Connection wizard.

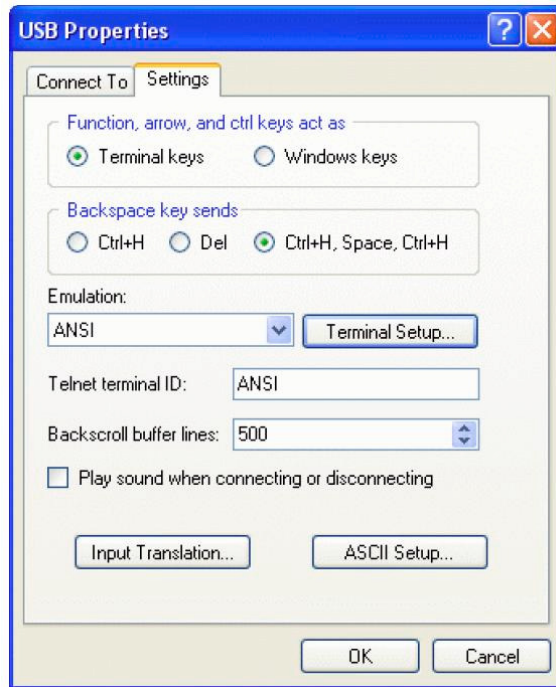
If you don't already have a connection saved, continue.

If you do, click cancel and then open the pre-existing connection and skip the remaining steps in this procedure.

2. Enter a name.  
Include the name of the interface you are intending to use for the connection as part of the name.
3. Click OK.
4. Select the COM port that is connected to the interface you wish to use to connect to the XG/XTR.

This is the COM port that you have your serial cable hooked up to or in the case of USB the one that was configured to be used in the FDTI software.

5. Click OK when done.
6. Setup the data format to be used. See “Data Format” on page 5-21 for details.
7. Set up the Hyper terminal you will need to configure the properties.
8. Click **File>Properties** to bring up the connection properties dialog and click on the Settings tab.



**Figure 5-14** USB Settings

9. Fill out the following selections in the connection properties dialog:

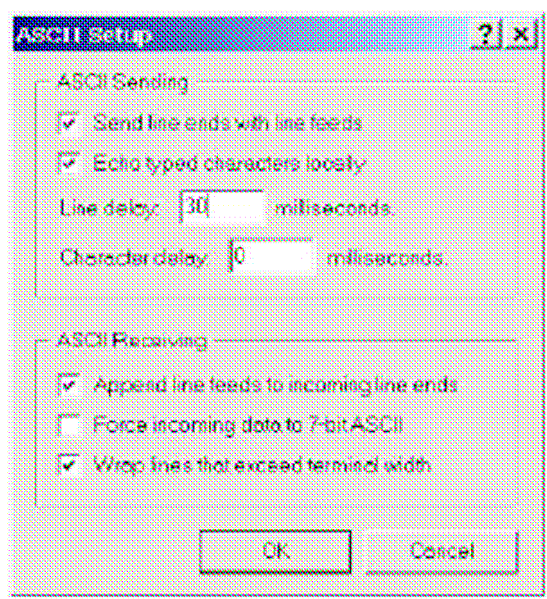
Terminal keys

Ctrl+H, Space, Ctrl+H.

On the Emulation list, select ANSI.

10. Click on the ASCII Setup button to bring up the ASCII Setup dialog.





**Figure 5-15** ASCII Setup

11. Check the following boxes:
  - Send line ends with line feeds.
  - Echo typed characters locally.
  - Append line feeds to incoming line ends.
  - Wrap lines that exceed terminal width.
12. Change the Line delay to 30 milliseconds.
13. Click OK in the ASCII Setup window.
14. Click OK in the Properties window.

HyperTerminal has now been configured to communicate with the XG/XTR.

## Selecting the Appropriate Communication Port

Five ports are available for remote digital programming and readback:

- RS-232
- RS-485
- USB
- GPIB (optional)
- ENET (optional)

### To select a communication port:

1. Turn the 9-position mode control to PGM.  
rEl is displayed in the output voltage display.
2. Turn the rotary Adjust/Enter control to select one of the communication ports: 232, 485, gPI b, USb, LAn.  
LOCL LOC is also an available option which lets you lock the front panel to prevent the settings from being changed.

---

**Important:** The remote interface that was previously configured when the local lock setting was activated will still be available for remote control while the front panel is locked.

---

## Data Rate Setting (Kbps)

The data rate setting is available for RS-232 and RS-485 protocols only. Five optional rates are possible: 1.2, 2.4, 4.8, 9.6 (default), 19.2, 38.4, and 57.6 kilo bits per second (Kbps).

### To select the desired rate:

1. Turn the 9-position mode control to PGM.  
rEl is displayed in the output voltage display.
2. Turn the rotary Adjust/Enter control to select 232 (RS-232) or 485 (RS-485) communication ports.
3. Press the rotary Adjust/Enter control.  
HbP5 is displayed on the output voltage display and the currently set data rate is displayed on the output current display.
4. Turn the rotary Adjust/Enter control to select the desired data rate.
5. Press enter to commit the new data rate.

The multichannel address setting will now be configured.

---

## Multichannel Address Setting

The power supply multichannel address can be set to any address between 1 to 30. All units that are connected together via the RS-232 or RS-485 connector must have a unique multichannel address.

### To set the address:

1. Select the appropriate communication port as described “Selecting the Appropriate Communication Port” on page 5-24.

If more than one unit has the same multichannel address when connected through the RS-485 connector, then collisions are possible, resulting in garbled responses to queries.

2. Press the rotary Adjust/Enter control.  
*Addr* is displayed on the output voltage display.
3. Turn the rotary Adjust/Enter control to select the desired multichannel address between 1 to 30.
4. Press the rotary Adjust/Enter control to commit the new address.

## Remote Interface Addressing

All commands must be issued with a multichannel address or the device must be selected using the:

`*adr or :SYST[<channel>]:COMM[:MCH]:ADDR` commands.

Once a device is selected all commands sent without a multichannel address will be handled by the selected device. The use of multichannel addresses supersedes the selected device as the destination for a message. For more details on how multichannel addresses affect responses, see Table 5-8.

To change the selected device simply issue the `*adr or :SYST[<channel>]:COMM[:MCH]:ADDR` command with a different multichannel address. The previously selected device will be deselected and the new device will be selected. From that point on, all messages without a multichannel address will be destined for the newly selected device. It is possible to deselect all devices by using the aforementioned commands with the broadcast address, 0.

### The SCPI Commands for these instructions are:

`[:]SYSTem:COMMunicate[:MCHannel]:ADDRess <address>`

or

`*ADR <address>`

Where:

`<address>` is the multichannel address of the device to be selected. The address is an integer value from 1 to 30.

## Multichannel Commands Explained

The use of multichannel addressing allows you to send messages to one device, more than one device or to all devices. Any of the remote interface types can be used to send a multichannel command through the device that is physically connected to the PC to all the devices, provided that all other devices are connected to via the RS-485 bus. In order to use multichannel addressing, the setup of the wiring should be completed as described in “Multiple Power Supply Connections to RS-485 Bus” on page 5-19.

All SCPI commands in the XG/XTR support the use of multichannel addressing; however, only one device can respond to a message. Responses will be sent according to the conditions set out in Table 5-8.

**Table 5-8** Rules for Multichannel Responses

Condition	Response	Example
No multichannel address used	Only the device selected using the *adr or :SYST [<address>] :COMM[:MCH]:ADDR commands will respond.	SYSTem:VERSion?
Single multichannel address specified	The device addressed in the command will respond regardless of if it has been selected.	SYSTem2:VERSion?
ALL or broadcast multichannel address specified	Only the device selected using the *adr or :SYST [<channel>]:C :COMM[:MCH]:ADDR commands will respond. If none of the devices have been selected then no response will be seen.	:SYSTem ALL:VERSion?  or :SYSTem0:VERSion?
Multiple multichannel addresses specified	Only the device selected using the *adr or :SYST [<address>] :COMM[:MCH]:ADDR commands will respond. If none of the device have been selected then no response will be seen.	SYSTem 1,2,4,5,6:VERSion?

Multichannel commands are particularly useful for configuring groups of devices that require identical configurations.

**The SCPI Commands for these instructions are:**

```
[:]<root command> <ALL|addr1>[, [ ]<addr2>][, [ ]<addr3>][, ...]:<command> <parameter>
```

For example:

```
sour 1, 2, 3, 7:volt 4.5  
syst4,5,6:oper:enab 255  
syst ALL:clear  
output0:stat on
```

## Status Reporting in SCPI

The status reporting implemented in the XG/XTR is primarily dictated by the SCPI standard. This section provides a high level review of the standard status reporting required by SCPI and then covers the XG/XTR specific reporting that is implemented within the SCPI status reporting framework.

Figure 5-16 is taken from the SCPI 99 standard and shows the minimum status reporting requirements for a SCPI compliant device.

Throughout this chapter, figures are used to explain the relationship between the registers, enable/disabling register and their summary bits. The figures use four logical symbols to demonstrate the relationship between the register. The “!” block represents logical not or complement of the input signal. The “&” block represents the logical AND operator. The “|” block represents the logical OR operation. The “+” block represents the logical OR of all the bits from the enable register. The model has several ellipses which are there to indicate that the pattern of logic shown is repeated for all bits in the registers.

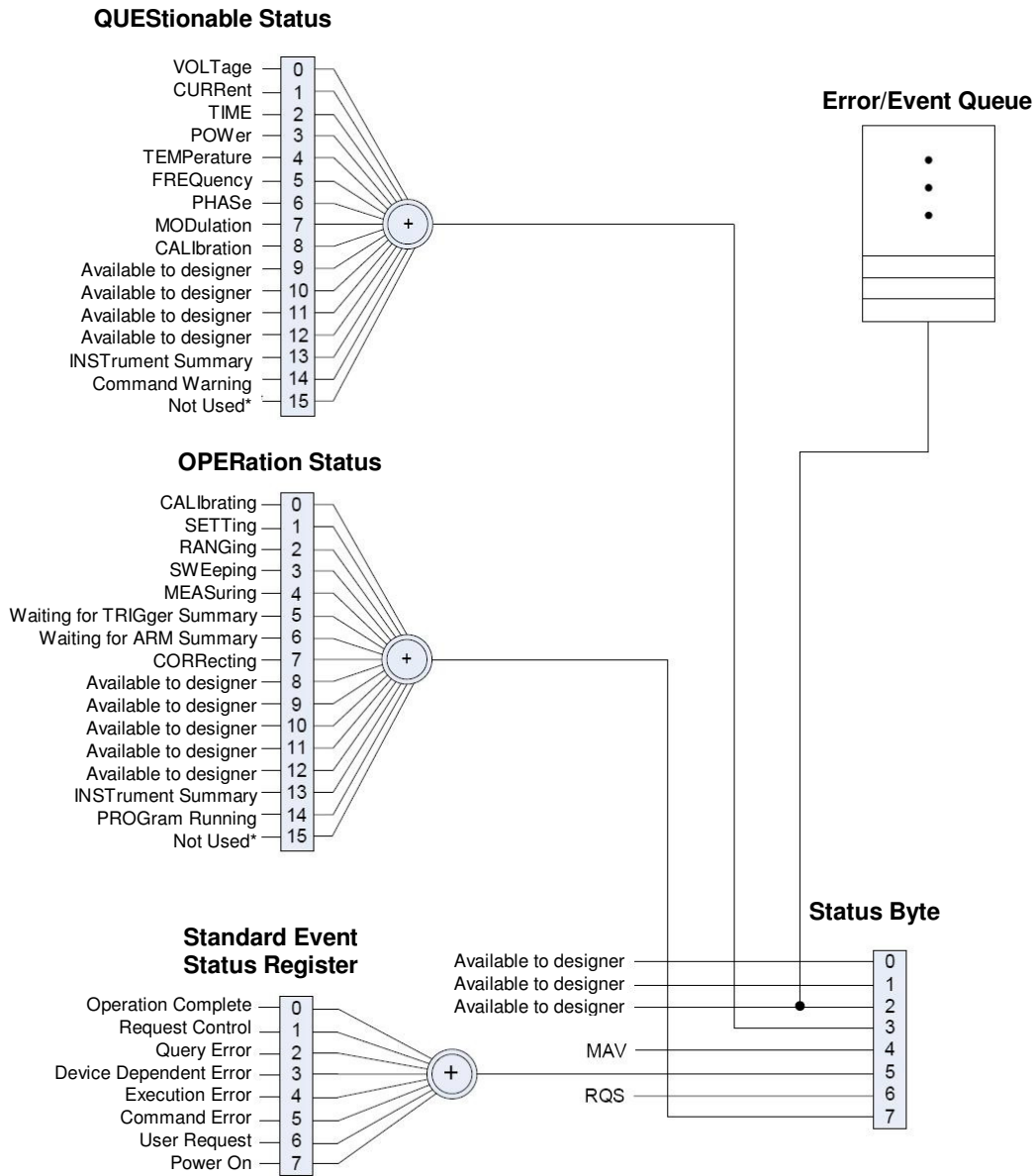


Figure 5-16 SCPI Status Reporting Model



## Status Registers Model from IEEE 488.2

The IEEE 488.2 registers shown in the bottom rectangle of Figure 5-16 follow the IEEE 488.2 model for status registers. The IEEE 488.2 register only has enable registers for masking the summary bits. Figure 5-17 shows the details on the relationship between the mask/enable registers and the summary bits. Sections describing the bits for both registers will follow Figure 5-17.

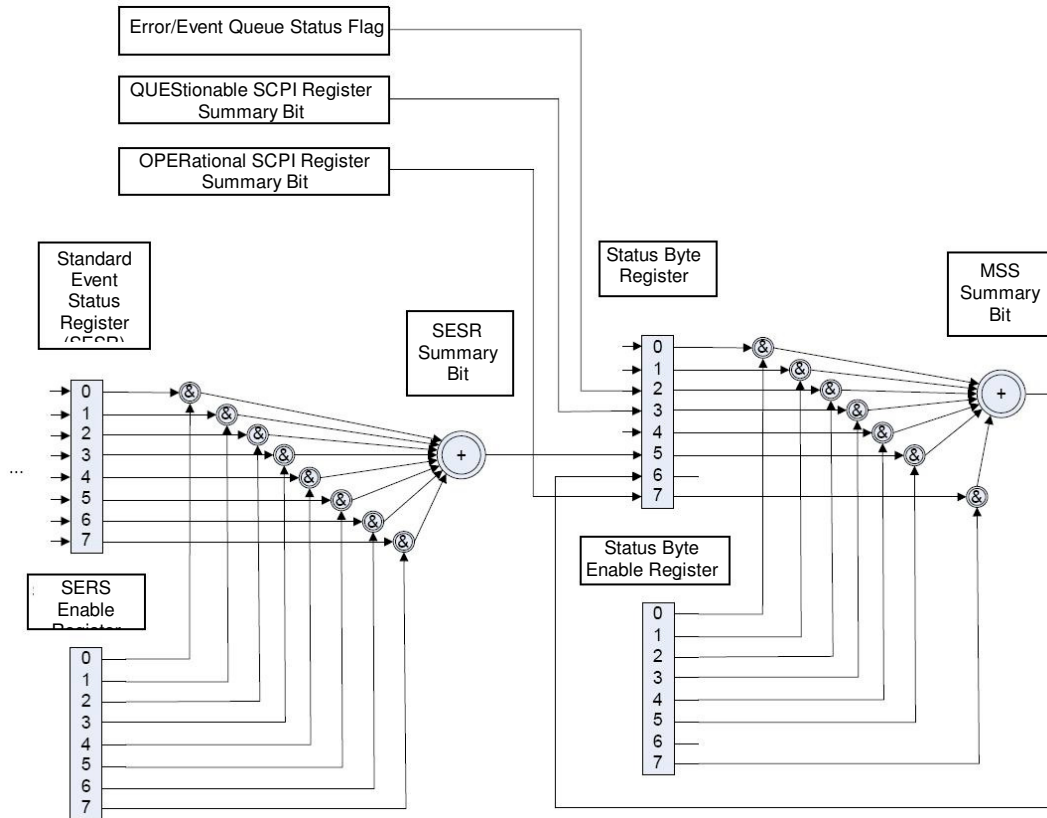


Figure 5-17 IEEE 488.2 Register Model

## Status Byte

The Status byte register contains the STB and RQS (MSS) messages as defined in 488.1. You can read the status byte register using a 488.1 serial poll or the 488.2 \*STB? common command.

The \*STB? query causes the device to send the contents of the Status Byte Register and the Master Summary Status (MSS) summary message. The \*STB? query does not alter the status byte, MSS, or RQS.

**Table 5-9** Status Byte Summary Register

Bit	Bit Weight	Bit Name	Description
0	1	Reserved	Reserved
1	2	Reserved	Reserved
2	4	Error/Event Queue (ERR)	Set if any errors are present in the Error/Event queue.
3	8	Questionable Status Register (QSR)	Set if any bits are set in the Questionable Status Event register.
4	16	Message Available (MAV)	Indicates whether the output queue is empty. MAV is TRUE if the device is ready to accept a request from the controller.
5	32	Standard Event Status Bit Summary (ESB)	A summary of the Standard Event Status Register.
6	64	Request Service (RQS) / Master Status Summary (MSS)	Not Implemented / MSS indicates that the device has at least one reason for requesting service.
7	128	Operation Status Register (OSR)	Present if a bit is set in the Operation status register.

### Error/Event Queue (ERR)

This bit is TRUE if any errors are present in the Error/Event Queue.

### Questionable Status Register Summary (QSR)

This bit is TRUE when a bit in the Questionable Event Status Register is set and its corresponding bit in the Questionable Status Enable Register is TRUE.

## Message Available (MAV)

This bit is TRUE whenever the power supply is ready to accept a request by the Digital Programming Interface to output data bytes. This message is FALSE when the output queue is empty.

## Standard Event Status Summary (ESB)

This bit is TRUE when a bit is set in the Standard Event Status Register.

## Master Summary Status (MSS)

This is caused by one of the following:

- Status Byte bit 0 AND Service Request Enable Register bit 0
- Status Byte bit 1 AND Service Request Enable Register bit 1
- Status Byte bit 2 AND Service Request Enable Register bit 2
- Status Byte bit 3 AND Service Request Enable Register bit 3
- Status Byte bit 4 AND Service Request Enable Register bit 4
- Status Byte bit 5 AND Service Request Enable Register bit 5
- Status Byte bit 7 AND Service Request Enable Register bit 7.

## Request Service (RQS)

RQS is TRUE if the Service Request Enable Register has a bit set and there is a corresponding bit within the Status Byte.

## Operation Status Register Summary (OSR)

This bit is TRUE when a bit in the Operation Event Status Register is set and its corresponding bit in the Operation Status Enable Register is set.

### Service Request Enable Register

The Service Request Enable Register allows you to select the reasons for the power supply to issue a service request. The Service Request Enable Register allows you to select which summary messages in the Status Byte Register may cause service requests.

To clear the Service Request Enable Register send `*SRE 0`. A cleared register does not allow status information to generate a service request.

For example:

Sending `*SRE 8` sets bit 3 of the Service Request Enable Register. This will cause the Summary bit of the Questionable Status register (bit 3) in the Status Byte to generate a service request message whenever it gets set. (See “Status Byte” on page 5-32 for details.)

#### Command:

```
*SRE <Service-Request-Enable>, *SRE?
```

#### The SCPI equivalent for multichannel use:

```
[:]STaTus[<channel>]:SREQuest[:ENABLE] <status-enable>  
[:]STaTus[<channel>]:SREQuest[:ENABLE?]
```

### Query the Status Byte

The status byte query will return the contents of the status byte register and the MSS (Master Summary Status) message. The response is in the format of a weighted decimal value representing the status byte register and the MSS message (bit 6). Thus, the response to `*STB?` is identical to the response to a serial poll except that the MSS message appears in bit 5 in place of the RQS message. (See “Status Byte” on page 5-32 for details.)

#### Command:

```
*STB?
```

#### SCPI equivalent:

```
[:]STaTus[<address>]:SBYte[:EVENT] ?
```

## Standard Event Status Register (SESR)

The standard event status register sets bits for specific events during power supply operation. All bits in the standard event status registers are set through the error event queue. The register is defined by IEEE 488.2 register and is controlled using 488.2 common commands: \*ESE, \*ESE?, and \*ESR? as well as SCPI aliases for multichannel use.

### Standard Event Status Enable Register

The Event Summary Enable command determines which bits in the Standard Event Status Register are summarized in the Event Summary Bit (ESB) of the Status Byte. This register will be cleared at power up. To enable events, you must make the logical sum of all values for the events that you to be reported and send this parameter in decimal format.

See Table 5-9 for values for the events to be enabled in <status-enable> parameter.

For example, sending \*ESE 16 sets bit 4 of the Standard Event Status Enable Register. This will cause the Event Summary bit (ESB) in the Status Byte to be set whenever the Execution Error bit (bit 4) in the Standard Event Status Register gets set.

#### Command:

```
*ESE <status-enable>, *ESE?
```

#### The SCPI equivalent for multichannel use:

```
[:]STATUS[<channel(s)>]:STANDARD:ENABLE <status-enable>
[:]STATUS[<channel(s)>]:STANDARD:ENABLE?
```

### Standard Event Status Register

The Standard Event Status Register query allows you to determine the current contents of the Standard Event Status Register. (See “Standard Event Status Register (SESR)”. Reading this register clears it.

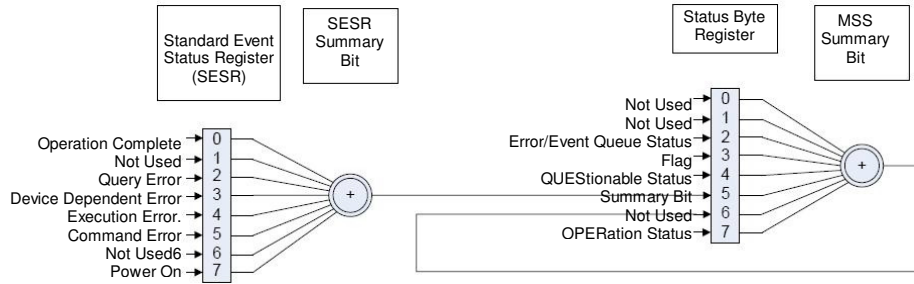
#### Command:

```
*ESR?
```

#### The SCPI equivalent for multichannel use:

```
[:]STATUS[<channel(s)>]:STANDARD[:EVENT]?
```

**Figure 5-18** summarizes the Standard Event Status Register.



**Figure 5-18 Summary of Standard Event Status Register**

**Table 5-10** Standard Event Status Register

Bit	Bit Weight	Bit Name	Description
0	1	Operation Complete (OPC)	Set if * OPC command has been received and all pending operations have been completed.
1	2	Request Control (RQC)	Not implemented. Always set to 0.
2	4	Query Error (QYE)	Not implemented.
3	8	Device Dependent Error (DDE)	Set if there is a device-specific error.  See “Device-Specific Error List” on page B-5 for a list possible error codes and descriptions.
4	16	Execution Error (EXE)	Set if a program data element, following a header, was evaluated by the power supply as outside of its legal input range, or is otherwise inconsistent with the power supply’s capabilities. Suggests that a valid program message could not be properly executed due to some power supply condition.  See “Execution Error List” on page B-4 for a list of possible error codes and descriptions.

**Table 5-10** Standard Event Status Register

Bit	Bit Weight	Bit Name	Description
5	32	Command Error (CME)	Set if an IEEE488.2 syntax error has been detected by the parser, an unrecognized header was received, or a group Execute Trigger was entered into the input buffer inside an IEEE 488.2 program message.  See “Command Error List” on page B-3 for a list of possible error codes and descriptions.
6	64	User Request (URQ)	Not Implemented
7	128	Power ON (PON)	Not Implemented
8-15	N/A	Reserved	Reserved for possible future use by IEEE. Bit values are reported as zero.

### Operation Complete

The Operation Complete command causes the power supply to generate the operation complete message in the Standard Event Status Register when all pending operations have been finished. See bit 0 in Table 5-10 for more details.

**Command:**

\*OPC,      \*OPC?

### Wait-to-Continue Command

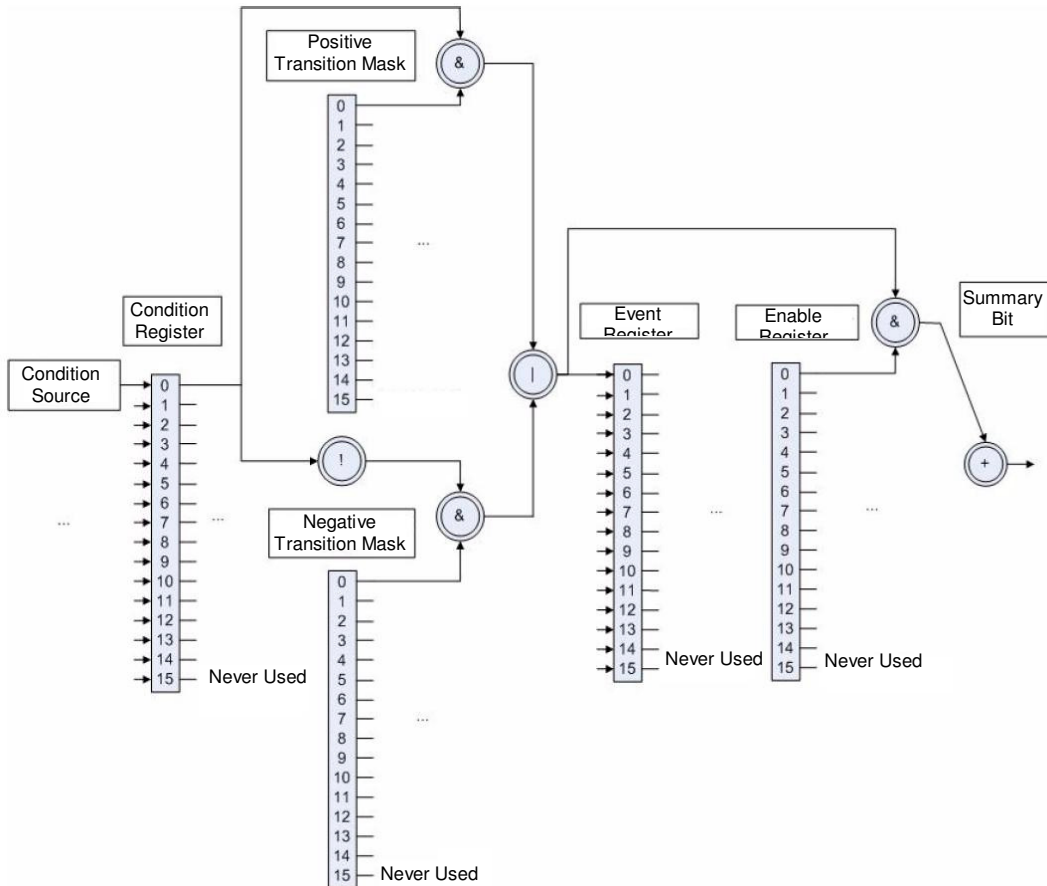
The Wait-to-Continue command prevents the power supply from executing any further commands or queries until the no-operation-pending flag is TRUE.

**Command:**

\*WAI

## Standard SCPI Register Structure

All registers except the SERS and Status registers will have the following structure which control how they report status information. In all subsequent figures that have SCPI registers, this structure will be condensed down into a single block to simplify the figures. The simplified block will show a 16-bit register and the summary bit. See Figure 5-19 for details on the structure used for each standard SCPI register.



**Figure 5-19** SCPI Register Model



# OPERation Status Register

The operation status register is a standard SCPI, 16-bit register which contains information about conditions which are part of the power supply's normal operation. The Operation Status data structure has the operation status register and two sub-registers to represent shutdown and protection shutdown. Each of the sub-registers is summarized in a summary bit.

Figure 5-20 represents the Operation Status data structure. The “+” represents the logical summation/or of bits in a register. Table 5-11, Table 5-12, and Table 5-13 describe the meanings of each bit as well as the bit number and bit weight.

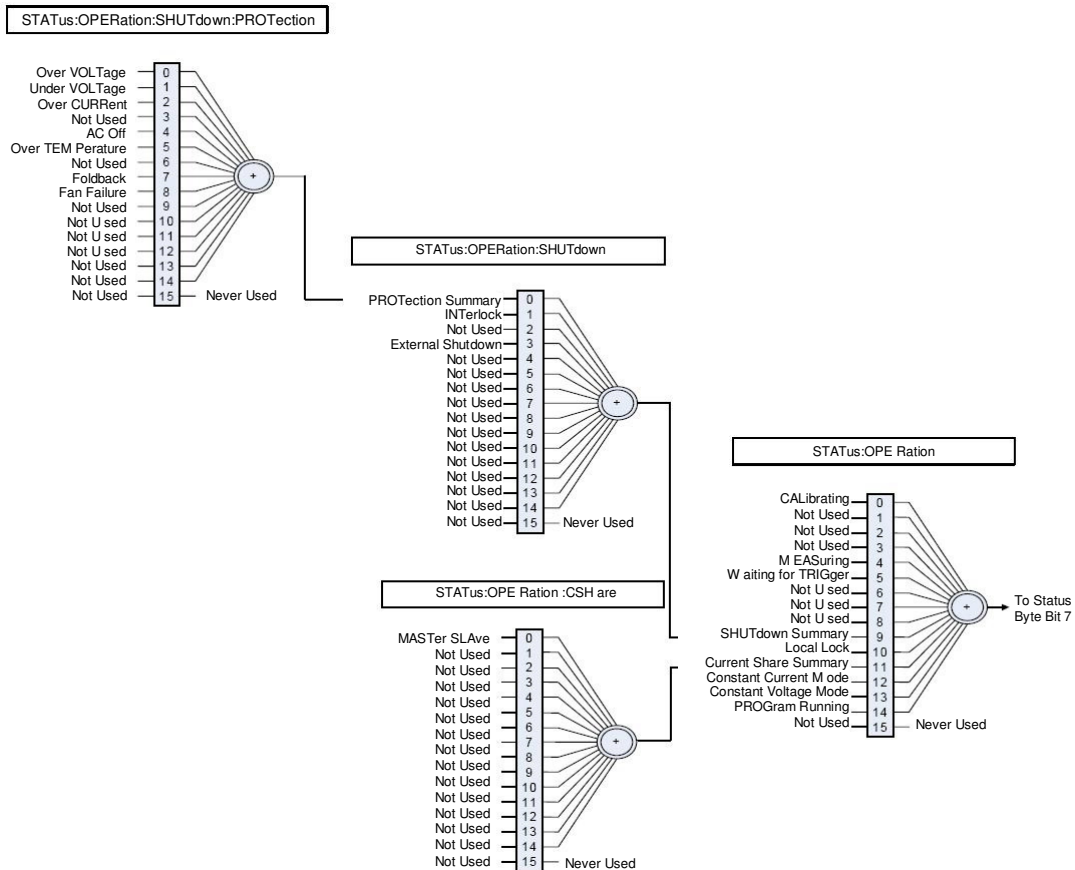


Figure 5-20 Operation Status Register Fanout

**Table 5-11** OPERation Status Register

Bit	Bit Weight	Bit Name	Description
0	1	CALibrating	Indicates that the supply is in CALibration Mode.
1	2	SETTling	Not implemented
2	4	RANGing	Not implemented
3	8	SWEEping	Not implemented
4	16	MEASuring	Not implemented
5	32	Waiting for Arm	Not implemented
6	64	Waiting for Trigger	Not implemented
7	128	CORRecting	Not implemented
8	256	Not Used	Not Used
9	512	SHUTdown Summary	Reflects the summary of the SHUTdown Sub-Register.
10	1024	Local Lockout	Front panel lockout
11	2048	Current Share Summary	Reflects the summary of the CSHare Sub-Register.
12	4096	Constant Voltage Mode	Reflects the output mode of the supply.
13	8192	Constant Current Mode	Reflects the output mode of the supply.
14	16384	Program Running	Indicates if an Autosequence program is currently running.

The operation shutdown status register describes the cause of the power supply shutting down the output. More than one bit may be active and multiple actions will be required to restart the unit. The protection shutdown sub-register indicates which protection mechanisms have caused the power supply to shutdown.

**Table 5-12** OPERation SHUTdown Status Register

Bit	Bit Weight	Bit Name	Description
0	1	PROTection	Reflects the summary of the PROTection sub-register.
1	2	INTeRlock	The power supply is shut down by INTeRlock signal.
2	4	Not Used	Not Used
3	8	External Shutdown	The power supply is shut down by External Shutdown signal.

**Table 5-13** OPERation SHUTdown PROTection Status Register

Bit	Bit Weight	Bit Name	Description
0	1	OVP	Over Voltage protection has tripped.
1	2	UVP	Under Voltage protection has tripped.
2	4	OCP	Over Current protection has tripped.
3	8	Not Used	Not Used
4	16	AC Off	AC failure protection has tripped.
5	32	OTP	Over Temperature protection has tripped.
6	64	Not Used	Not Used
7	128	Foldback	Foldback protection has tripped.
8	256	Fan	Fan failure protection has tripped.

## Current SHare Sub-Register

This register shows the state of the current share configuration, which can either be set through the front panel Current Share Config menu, or through the SCPI command.

---

**Important:** If current sharing is not being used, the unit must be configured as a controller. Failure to do so will result in unpredictable operation.

---

**The SCPI command (s) for these instructions are:**

[[:]SOURce]:COMBine:CSHare[:MODE]

**Table 5-14** OPERation CSHare Status Register

Bit	Bit Weight	Bit Name	Description
0	1	CONTroller	The power supply is configured to be a Current Share CONTroller.
1	2	SLAVe	The power supply is configured to be a Current Share Slave.

---

## Operation Status Register Commands

The response format for all register queries will be in decimal notation.

### Query Operation Status Register Event

**SCPI command:**

```
[:]STATUS[<channel>]:OPERation[:EVENT]?
```

### Query Operation Status Register Condition

**SCPI command:**

```
[:]STATUS[<channel>]:OPERation:CONDition?
```

### Enable Operation Status Register

**SCPI command:**

```
[:]STATUS[<channel>]:OPERation:ENABLE <status-enable>
```

**Query Format:**

```
[:]STATUS[<channel>]:OPERation:ENABLE?
```

### Set Operation Status Positive Transition Filter

**SCPI command:**

```
[:]STATUS[<channel>]:OPERation:PTRansition <status-enable>
```

**Query Format:**

```
[:]STATUS[<channel>]:OPERation:PTRansition?
```

### Set Operation Status Negative Transition Filter

**SCPI command:**

```
[:]STATUS[<channel>]:OPERation:NTRansition <status-enable>
```

**Query Format:**

```
[:]STATUS[<channel>]:OPERation:NTRansition?
```

## Current Sharing Sub-Register Commands

### Query Current Share Event

**SCPI command:**

[:]STATUS [<channel>]:OPERation:CSHare[:EVENT]?

### Query Current Share Condition

**SCPI command:**

[:]STATUS [<channel>]:OPERation:CSHare:CONDition?

### Enable Current Share Sub-Register

**SCPI command:**

[:]STATUS [<channel>]:OPERation: CSHare:ENABLE  
<statusenable>

**Query format:**

[:]STATUS [<channel>]:OPERation:CSHare:ENABLE?

### Set Current Share Positive Transition Filter

**SCPI command:**

[:]STATUS [<channel>]:OPERation:CSHare:PTRansition  
<status-enable>

**Query format:**

[:]STATUS [<channel>]:OPERation:CSHare:PTRansition?

### Set Current Share Negative Transition Filter

**SCPI command:**

[:]STATUS [<channel>]:OPERation:CSHare:NTRansition  
<status-enable>

**Query format:**

[:]STATUS [<channel>]:OPERation:CSHare:NTRansition?

---

## Shutdown Sub-Register Commands

### Query Shutdown Event

**SCPI command:**

```
[:]STATUS [<channel>]:OPERation:SHUTdown[:EVENT]?
```

### Query Shutdown Condition

**SCPI command:**

```
[:]STATUS [<channel>]:OPERation:SHUTdown:CONDition?
```

### Enable Shutdown Sub-Register

**SCPI command:**

```
[:]STATUS [<channel>]:OPERation: SHUTdown:ENABLE  
<status-enable>
```

**Query format:**

```
[:]STATUS [<channel>]:OPERation:SHUTdown:ENABLE?
```

### Set Shutdown Positive Transition Filter

**SCPI command:**

```
[:]STATUS [<channel>]:OPERation:SHUTdown:PTRansition  
<status-enable>
```

**Query format:**

```
[:]STATUS [<channel>]:OPERation:SHUTdown:PTRansition?
```

### Set Shutdown Negative Transition Filter

**SCPI command:**

```
[:]STATUS [<channel>]:OPERation:SHUTdown:NTRansition  
<status-enable>
```

**Query format:**

```
[:]STATUS [<channel>]:OPERation:SHUTdown:NTRansition?
```

## Protection Sub-Register Commands

### Query Protection Event

**SCPI command:**

```
[:]STATUS [<channel>]:OPERation:SHUTdown:PROTection[:EVENt]?
```

### Query Protection Condition

**SCPI command:**

```
[:]STATUS [<channel>]:OPERation:SHUTdown:PROTection:CONDition?
```

### Enable Protection Sub-Register

**SCPI command:**

```
[:]STATUS [<channel>]:OPERation:SHUTdown:PROTection:ENABle <status-enable>
```

**Query format:**

```
[:]STATUS [<channel>]:OPERation:SHUTdown:PROTection:ENABle?
```

### Set Protection Positive Transition Filter

**SCPI command:**

```
[:]STATUS [<channel>]:OPERation:SHUTdown:PROTection:PTRAnstition <stats-enable>
```

**Query format:**

```
[:]STATUS [<channel>]:OPERation:SHUTdown:PROTection:PTRAnstition?
```

### Set Protection Negative Transition Filter

**SCPI command:**

```
[:]STATUS [<channel>]:OPERation:SHUTdown:PROTection:NTRAnstition <status-enable>
```

**Query format:**

```
[:]STATUS [<channel>]:OPERation:SHUTdown:PROTection:NTRAnstition?
```



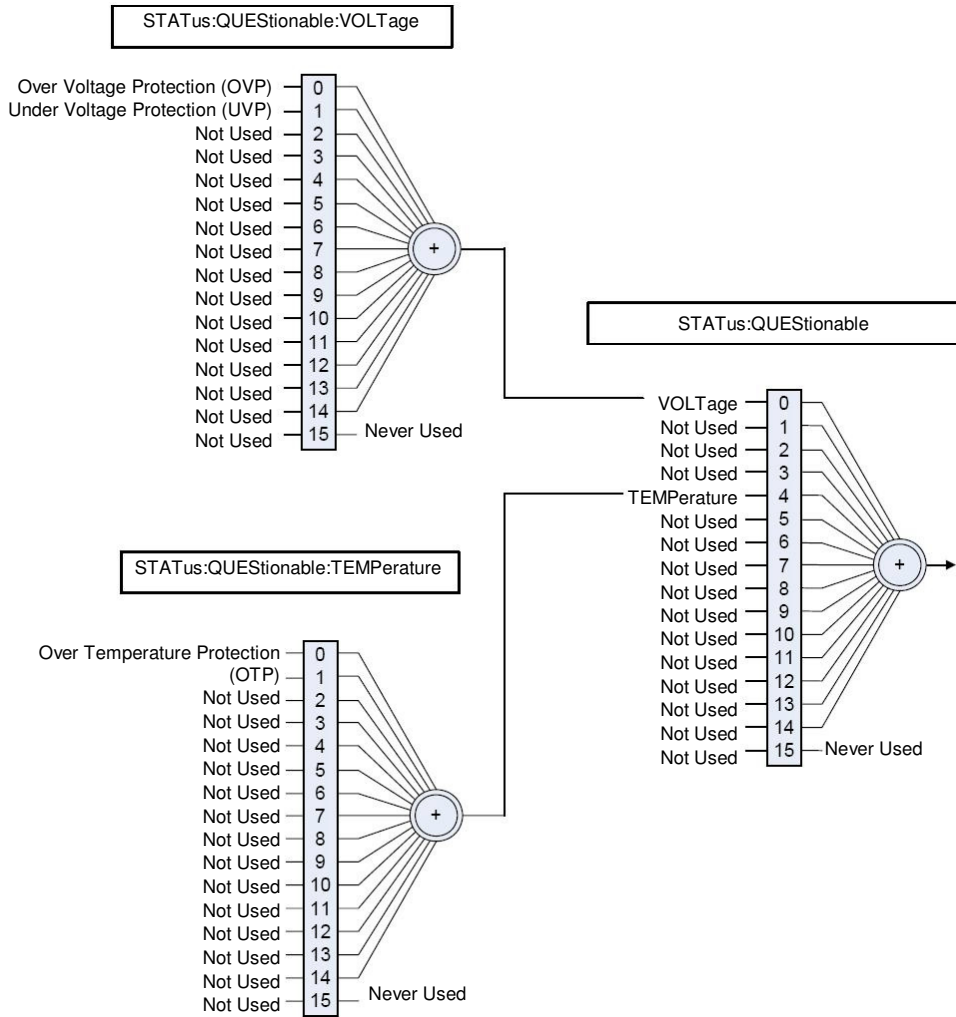
---

## QUESTIONABLE Status Register

The Questionable Status register is a standard SCPI, 16-bit register that stores information about questionable events or status during power supply operation. That is, bits in these registers may indicate that the output of the supply is of undesirable or questionable quality.

The Questionable Status data structure consists of a questionable status register and two sub-registers representing the status of the voltage outputs and temperature.

Figure 5-21 gives an overview of the Questionable Status data structure. The “+” represents the logical summation of bits in a register. Table 5-15 Table 5-16, and Table 5-17 describe the meanings of each bit as well as the bit number and bit weight.



**Figure 5-21** SCPI QUESTIONable Registers Fanout

**Table 5-15** QUEStionable Status Register

Bit	Bit Weight	Bit Name	Description
0	1	VOLTage	Summary of Voltage Register
1	2	CURRent	Not Implemented
2	4	TIME	Not Implemented
3	8	POWer	Not Implemented
4	16	TEMPerature	Summary of Temperature Register
5	32	FREQuency	Not Implemented
6	64	PHASe	Not Implemented
7	128	MODulation	Not Implemented
8	256	CALibration	Not Implemented
9	512	Not Used	Not Used
10	1024	Not Used	Not Used
11	2048	Not Used	Not Used
12	4096	Not Used	Not Used
13	8192	Not Used	Not Used
14	16384	Not Used	Not Used
15	32768	Not Used	Not Used

## VOLTage Sub-Register

This shows whether the present voltage level is over or under the specified trip limit.

**Table 5-16** QUESTIONable VOLTage Status Register

Bit	Bit Weight	Bit Name	Description
0	1	OVP	Over Voltage Protection
1	2	UVP	Under Voltage Protection

## TEMPerature Sub-Register

This shows whether the temperature of critical components is near or over the maximum operating temperature.

**Table 5-17** QUESTIONable TEMPerature Status Register

Bit	Bit Weight	Bit Name	Description
0	1	OTP	Over Temperature Protection

## Reading Internal Temperature Measurements

Internal temperatures are measured by the channels of a fan controller. The XG/XTR 850 has one fan controller, Fan0, with two channels, 0 and 1, that each control a fan and measure temperature. The XG/XTR 1700 has two fan controllers, Fan0 with two channels, 0 and 1, and Fan1 with two channels, 0 and 1 (four fans total).

### The SCPI command (s) for these readings are:

```
DIAGnostic:MEMory:FAN<n>:READ #h0<n>
```

Example: to read the temperatures in the XG/XTR 850,

```
DIAG:MEM:FAN0:READ #h00 //this reads the 1st channel
```

```
DIAG:MEM:FAN0:READ #h01 //this reads the 2nd channel
```

To read temperatures in the XG/XTR 1700 send either or both of the above example commands for the channel(s) of the first fan, and input FAN1 in place of FAN0 to read the temperature measurements taken by the channel(s) of the second fan.

---

## Questionable Status Register Commands

### Query Questionable Status Register Event

**SCPI command:**

```
[:]STATUS[<channel>]:QUESTionable[:EVENT]?
```

### Query Questionable Status Register Condition

**SCPI command:**

```
[:]STATUS[<channel>]:QUESTionable:CONDition?
```

### Enable Questionable Status Register

**SCPI command:**

```
[:]STATUS[<channel>]:QUESTionable:ENABle <status-  
enable>
```

**Query Format:**

```
[:]STATUS[<channel>]:QUESTionable:ENABle?
```

### Set Questionable Status Positive Transition Filter

**SCPI command:**

```
[:]STATUS[<channel>]:QUESTionable:PTRansition <status-  
enable>
```

**Query Format:**

```
[:]STATUS[<channel>]:QUESTionable:PTRansition?
```

### Set Questionable Status Negative Transition Filter

**SCPI command:**

```
[:]STATUS[<channel>]:QUESTionable:NTRansition <status-  
enable>
```

**Query Format:**

```
[:]STATUS[<channel>]:QUESTionable:NTRansition?
```

## Voltage Status Register Commands

### Query Voltage Status Register Event

**SCPI command:**

```
[:]STATUS[<channel>]:QUESTIONABLE:VOLTage[:EVENT]?
```

### Query Voltage Status Register Condition

**SCPI command:**

```
[:]STATUS[<channel>]:QUESTIONABLE:VOLTage:CONDition?
```

### Enable Voltage Status Register

**SCPI command:**

```
[:]STATUS[<channel>]:QUESTIONABLE:VOLTage:ENABLE  
<status-enable>
```

**Query Format:**

```
[:]STATUS[<channel>]:QUESTIONABLE:VOLTage:ENABLE?
```

### Set Voltage Status Positive Transition Filter

**SCPI command:**

```
[:]STATUS[<channel>]:QUESTIONABLE:VOLTage:PTRansition  
<status-enable>
```

**Query Format:**

```
[:]STATUS[<channel>]:QUESTIONABLE:VOLTage:PTRansition?
```

### Set Voltage Status Negative Transition Filter

**SCPI command:**

```
[:]STATUS[<channel>]:QUESTIONABLE:VOLTage:NTRansition  
<status-enable>
```

**Query Format:**

```
[:]STATUS[<channel>]:QUESTIONABLE:VOLTage:NTRansition?
```

---

## Temperature Status Register Commands

### Query Temperature Status Register Event

**SCPI command:**

```
[:]STATUS [<channel>]:QUESTIONable:VOLTage:TEMPerature  
[:EVENT]?
```

### Query Temperature Status Register Condition

**SCPI command:**

```
[:]STATUS [<channel>]:QUESTIONable:VOLTage:TEMPerature  
:CONDition?
```

### Enable Temperature Status Register

**SCPI command:**

```
[:]STATUS [<channel>]:QUESTIONable:VOLTage:TEMPerature  
:ENABLE <status-enable>
```

**Query Format:**

```
[:]STATUS [<channel>]:QUESTIONable:VOLTage:TEMPerature  
:ENABLE?
```

### Set Temperature Status Positive Transition Filter SCPI command:

```
[:]STATUS [<channel>]:QUESTIONable:VOLTage:TEMPerature  
:PTRansition <status-enable>
```

**Query Format:**

```
[:]STATUS [<channel>]:QUESTIONable:VOLTage:TEMPerature  
:PTRansition?
```

### Set Temperature Status Negative Transition Filter

**SCPI command:**

```
[:]STATUS [<channel>]:QUESTIONable:VOLTage:TEMPerature  
:NTRansition <status-enable>
```

**Query Format:**

```
[:]STATUS [<channel>]:QUESTIONable:VOLTage:TEMPerature  
:NTRansition?
```

## SCPI Error/Event Queue

The error/event queue contains items that include a numerical and textual description of the error or event. Querying for the full queue item (for example, with `SYSTem:ERRor[:NEXT]?`) will return a response with the following syntax:

```
<Error/Event Number>, "<Error/Event  
Description>;<Optional Device Dependent Info>"
```

The `<Error/event_number>` is a unique integer in the range [-32768, 32767]. All positive numbers are instrument-dependent. All negative numbers are reserved by the SCPI standard with certain standard error/ event codes described in the SCPI 1999 standard document. The value, zero, is also reserved to indicate that no error or event has occurred.

The second parameter of the full response is a quoted string containing an `<Error/event_description>` followed by optional `<Device-dependent info>` text. Each `<Error/event_number>` has a unique and fixed `<Error/ event_description>` associated with it.

The maximum string length of `<Error/event_description>` plus `<Device-dependent_info>` is 255 characters.

As errors and events are detected, they are placed in a queue. This queue is first in, first out. If the queue overflows, the last error/event in the queue is replaced with error:

```
-350,"Queue overflow
```

Any time the queue overflows, the least recent errors/events remain in the queue, and the most recent error/event is discarded. The error queue implemented in the XG/XTR is capable of holding 4 errors.

When the error queue is not empty the error queue bit in the Status register will be set.

### Querying For the Errors

Executing a query of the event queue will respond with the oldest error currently on the queue. This error is removed. The response format is discussed in the error/event queue description section.

**Command:**

```
[:]SYSTem:ERRor[:EVENT]?
```



**Examples:**

```
SYST:ERR?  
SYST:ERR:EVENT?
```

**Responses might be:**

```
-102, "syntax error;"  
0, "No Error;"
```

**Querying For the Error Code Only**

It is possible to query for only the error code. When querying the error code only the response will be the numeric error code only, no additional description will be given. The error queried will be removed from the queue.

**Command:**

```
[:]SYSTem:ERRor:CODE[:EVENT]?
```

**Example:**

```
:SYST:ERR:CODE?  
SYST:ERR:CODE:EVENT ?
```

**Responses might be:**

```
-102  
0
```

**Querying For the Number of Errors in the Queue**

To query the device for the number of errors currently stored in the error queue you should use the following command.

**Command:**

```
[:]SYSTem:ERRor:COUNT?
```

**Example:**

```
:SYST:ERR:COUN?
```

**Response might be:**

```
3
```

## Reset Command

The Reset command performs a device reset. The Reset command is the third level of reset in a three level reset strategy, set out in IEEE 488.2 (see IEEE 488.2 standard, section 17.1.2).

**The Reset command shall do the following:**

1. Set the device-specific functions to a known state that is independent of the past-use history of the device. See Table 3-9, “Power Supply Default Settings” on page 3-41 for details.
2. Force the device into the OCIS state, (see IEEE 488.2 standard, section 12.5.2).
3. Force the device into the OQIS state, (see IEEE 488.2 standard, section 12.5.3).

**The reset command explicitly shall NOT affect the following:**

1. The state of the IEEE 488.1 interface.
2. The selected IEEE 488.1 address of the device.
3. The Output Queue.
4. The Standard Status Register Enable setting.
5. The Standard Event Status Enable (SESR) setting.
6. The Operation and Questionable SCPI status registers and their fan out registers.
7. Calibration data that affects device specifications.
8. The Protected User Data query response.

**Commands:**

```
*RST  
[:]SYSTem[<channel>]:RESet
```

## Clear All Status Registers

### Clear Status Command

Clears all Event Registers, including the Status Byte, the Standard Event Status and the Error Queue.

**Command:**

\*CLS

[:]STaTus [<channel>]:CLear

## SCPI Preset Status

Configures the status data structures to ensure that certain events are reported at a higher level through the status-reporting mechanism. These events are summarized in the mandatory structures, the Operation Status Register and Questionable Status Register.

The PRESet command affects only the enable registers and the transition filter registers of the status data structures. PRESet does not clear any of the event registers or any item from the error/event queue. The \*CLS command is used to clear all event registers and queues in the device status-reporting mechanism.

For the device-dependent status data structures, the PRESet command sets the enable register to all 1s and the transition filter register to report only positive transitions. For the SCPI mandatory status data structures, the PRESet command sets the transition filter registers to recognize only positive transitions and sets the enable register to 0s. The following will not be affected by this command: Service Request Enable Register, Parallel Poll Enable Register, the memory register associated with the \*SAV command, the power supply address, Output Queue, and the power-on-status-clear flag setting.

**Table 5-18** Preset Values of User Configurable Registers

Register	Filter/Enable	Preset Value
Operational	Operational Enable Register	0
	Positive Transition Filter	1
	Negative Transition Filter	0
Questionable	Questionable Enable Register	0
	Positive Transition Filter	1
	Negative Transition Filter	0
All others	All other Enable Register	1
	Positive Transition Filter	1
	Negative Transition Filter	1

**SCPI command:**

```
[:] STATus [<channel>] :PRESet
```

## Command Line Help System

The Help system is made up of a series of commands that can be used to get help on all available commands and details on their syntax.

### The Help commands are:

```
[ : ] SYSTem[ <channel> ] :HELP [ :HEADers ] ?
[ : ] SYSTem[ <channel> ] :HELP:LEGacy?
```

### Querying Help for all Command Headers

The [ : ] SYSTem [ <channel> ] : HELP [ : HEADers ] ? query shall return all SCPI commands and queries and IEEE 488.2 common commands and common queries implemented. No single line will be longer than 80 characters long. The full path for every command and query shall be returned separated by line feeds.

A <SCPI header> is defined as:

It shall contain all the nodes from the root. The <SCPI program mnemonic> contains the node in standard SCPI format. The short form shall use uppercase characters while the additional characters for the long form shall be in lowercase characters. Default nodes shall be surrounded by square brackets ( [ ] ).

### Command:

```
[ : ] SYSTem[ <channel> ] :HELP [ :HEADers ] ?
```

For example:

```
:SYST1:HELP:HEAD?
```

Might return:

```
#44513
*IDN?/qonly/
*RST/nquery/
*TST?/qonly/
*OPC/nquery/
*OPC?/qonly/
*WAI/nquery/
*CLS/nquery/
*ESE
*ESR?/qonly/
```

```
*SRE
*SRE?/qonly/
*STB?/qonly/
*SAV
*RCL
*TRG/nquery/
*ADR
*HELP?/qonly/
*ERR?/qonly/
[:]SYSTem:PROTection[:MASK]
[:]SYSTem:ERRor[:NEXT]?/qonly/
[:]SYSTem:ERRor:CODE[:NEXT]?/qonly/
[:]SYSTem:ERRor:COUnT?/qonly/
...
[:]OUTPut:PROTection:FOLDback[:MODE]
[:]OUTPut:PROTection:FOLDback:
[:]OUTPut:POLarity
[:]OUTPut[:POWer][:STATe]
[:]OUTPut[:POWer]:PON[:STATe]
[:]OUTPut:AUXilliary[:STATe]
[:]OUTPut:AUXilliary:PON[:STATe]
[:]MEASure[:SCALar][:VOLTagE][:DC]?/qonly/
[:]MEASure[:SCALar]:CURRent[:DC]?/qonly/
[:]MEASure[:SCALar]:APROgram[:VOLTagE][:DC]?/qonly/
[:]MEASure[:SCALar]:APROgram[:VOLTagE]:ISOLated[:DC]?/
qonly/
[:]MEASure[:SCALar]:APROgram:CURRent[:DC]?/qonly/
[:]MEASure[:SCALar]:APROgram:CURRent:ISOLated[:DC]?/
qonly/
[:]INITiate:IMMediate/nquery/
[:]CALibration:REStore/nquery/
[:]CALibration[:VOLTagE]:PROTection[:OVER][:DATA]/nquer
y/
[:]CALibration:OUTPut[:VOLTagE][:DATA]/nquery/
[:]CALibration:OUTPut:CURRent[:DATA]/nquery/
[:]CALibration:OUTPut:ANALog[:VOLTagE][:DATA]/nquery/
[:]CALibration:OUTPut:ANALog[:VOLTagE]:ISOLated[:DATA]/
nquery/
```

## Querying Help for Legacy Command Headers

The `[ : ] SYSTem [<channel>] : HELP: LEgacy?` query is essentially the same as the `[ : ] SYSTem [<channel>] : HELP [ :HEADers]?` query, but it lists legacy commands. If executed it returns all legacy commands and queries implemented. The response shall be on a page by page basis. No single line will be longer than 80 characters and each page will be 23 lines long. The full path for every command and query shall be returned separated by line feeds. After a full page of headers has been displayed you will be prompted to press any key to continue or the ESC key to stop any further listing of the command headers.

### Command:

```
[ : ] SYSTem [<channel>] : HELP: LEGacy?
```

For example:

```
: SYST2: HELP: LEG?
```

Might return:

```
#296
AUX
OUT
ERR?/qonly/
CLR/nquery/
FOLD
DLY
VSET
ISET
TRG/nquery/
OVP
UVP
HELP?/qonly/
HLP?/qonly/
```

## Locking and Unlocking the Front Panel

Locking out the front panel will prevent any of the buttons from functioning. All the buttons and knobs on the front panel will display the LOCL LOC message to be display on the Current and Voltage displays if pressed or rotated. This mode prevents any changes to the unit from the front panel. See the following procedure to lock and unlock the front panel.

### The SCPI Commands for these instructions are:

```
[:]SYSTem[<channel>]:REMOte:STATe {?|LOCAl|REMOte}
```

Where:

LOCAl is used to set the front panel mode to local.

REMOte is used to set the front panel into locked mode (remote).

For example:

```
SYST : REM: STAT REM Front panel is locked (remote digital programming mode only).
```

```
SYST : REM: STAT LOC Front panel is unlocked.
```

```
SYST : REM: STAT ? Query for status
```

## Auto Sequence Programming

Auto Sequence programming lets you execute a program stored in the power supply's memory. The program that can be stored in memory can be composed of any of the SCPI commands described in this Manual.

For example, Auto Sequence programming allows you to set the timer to turn the power output of the supply Off or On after a time interval or to program voltage sequences.

When a program is activated each command stored in the buffer is executed as if the operator had sent the command by typing it in. A variable delay time called dwell is spent between commands. The dwell time can range from 0 seconds to 180 seconds. See "Setting Dwell Time" on page 5-63.

The Auto Sequence program will be cleared after AC power is turned off; however, a procedure exists for storing it in a text file which can be reloaded at a later date.



## Setting Dwell Time

The dwell time is the amount of time that is delayed between each command during the execution of an Auto Sequence program. The dwell time can be from 0 to 180 seconds and can be changed during the program execution. The dwell time has a minimum step size of 1 second.

### Command:

```
[:]PROGram[<channel>][:STEP]:DWELl {?|<dwell time> }
```

Where:

<dwell time > is an integer value from 0 to 180.

For Example:

:PROG:DWEL 12 Results in 12 seconds of wait time after each command is executed.

## Storing an Auto Sequence Program:

Loading a program into memory is done by using the [: ] PROGram [ <channel> ] [: RECord ] : START command. After the start command has been issued, the XG/XTR will record all subsequent commands into the auto sequence program buffer. The commands will be recorded into the buffer until the : PROGram [ <channel> ] [: RECord ] : STOP command is issued.

### Commands:

```
[:]PROGram[<channel>][:RECord]:START
```

```
[:]PROGram[<channel>][:RECord]:STOP
```

---

**Important:** If the start recording command is executed then any previously stored Auto Sequence program is deleted.

---

For example:

```
:PROG:STAR
:VOLT 12
:OUTP ON
:PROG:DWEL 60
:OUTP OFF
:OUTP ON
:OUTP OFF
```

```
:PROG:DWEL 0
:PROG:STOP
```

This program will send a 12 V square wave with 120 seconds 50% duty cycle. When the program is finished, the dwell time is restored to 0 seconds.

### **Saving an Auto Sequence Program to File:**

The following procedure indicates how to save an Auto Sequence program to a text file on the attached PC.

#### **To save an Auto Sequence Program to a file:**

1. Start the text capture by selecting **Transfer>Capture Text ...** from the Hyper Terminal program.
2. Set the location and name of the auto sequence to be captured.
3. Click the Start button.
4. Execute a program read back by sending:  
:PROG [<channel>] :READ?
5. Stop the text capture by selecting **Transfer>Capture Text>Stop** from the Hyper Terminal program.
6. Using any text editor open the file which you captured the Auto Sequence program to.
7. Remove the first line which should read “:PROG [<channel>]:READ?” and the first blank line. This makes the first line of the program the first line of the file.
8. Save the file and exit the text editor.

The Auto Sequence program has now been stored and can be sent to any unit. See “Reloading an Auto Sequence Program:” on page 5-65 for details.

### **Readback and Troubleshooting an Auto Sequence Program:**

Since the Auto Sequence programming function records the commands at program time without verifying the syntax, it can be difficult to spot an error in the sequence, for example, if a typo was made when entering a command during the record phase. A readback command has been provided to output the stored auto sequence program currently in memory.

Another benefit to the readback command is it allows the auto sequence program to be captured and stored on the client side for reloading when the program is to persist beyond power cycles.

**Command:**

```
[:]PROGram[<channel>]:READback?
```

**For Example:**

```
:PROG:START  
*CLS  
:VOLT 5.4  
:CURR 0.25  
*IDN?  
:PROG:STOP  
:PROG:READ?
```

**Response:**

```
*CLS  
:VOLT 5.4  
:CURR 0.25  
*IDN?  
:PROG:STOP
```

**Reloading an Auto Sequence Program:**

The following procedure will demonstrate how to store a command beyond a power cycle of the unit.

---

**Important:** This functionality is only available through USB, RS-232 and RS-485. It is not possible to reload an auto sequence program over the GPIB and ENET\_cards.

---

**To reload Auto Sequence program from file:**

1. Set the data rate of the device to be 1200 bps.
2. Close the connection to the hyperterminal program and configure the connection data rate to be 1200 bps.
3. Execute the program recording command:

```
:PROG:START
```

4. From the Hyper Terminal (or any other terminal program) select the **Transfer>Send Text File...**
5. Navigate to and select the text file that was previously stored. Click the Open button.
6. Execute the program recording stop command:  
:PROG:STOP
7. Execute the readback command to verify the entire program was transferred correctly:  
PROG:READ?
8. Set the data rate back to the original speed.
9. Close the connection to the HyperTerminal program and configure the connection data rate to be the original speed.

### Running an Auto Sequence Program:

Once an auto sequence program has been stored, there are a few commands that can be used to run the program. Once a program begins running, it will continue running until completion and then repeat the number of times specified by the repeat command. The default at power on is to have repeat set to 1.

#### Commands:

```
*TRG  
[:]INITiate[<channel>][:IMMediate]  
[:]PROGram[<channel>]:STATe {?|RUN|STOP|PAUSE}
```

#### Where:

RUN causes the program to begin execution.

STOP causes the program to stop execution

PAUSE causes the program to stop executing at the current command. If a subsequent run is sent, the program will resume executing with the next command in the program.

#### For Example:

```
:PROG:STAR  
*IDN?  
*IDN?  
:PROG:STOP
```

```
:PROG:STAT RUN
```

The output after the last command might be as follows:

```
AMETEK, XG (or XTR) 150-5.6, SN# E00123456, 1.00
Build 10, 21/ 11/2005
```

```
AMETEK, XG (or XTR) 150-5.6, SN# E00123456, 1.00
Build 10, 21/ 11/2005
```

---

**Important:** Execution of the program may be terminated at any time by pressing the Esc key in the MS Windows Hyper Terminal window. The power supply can be controlled during program execution.

---

### Deleting an Auto Sequence Program:

It is possible to delete the current Auto Sequence Program using the SCPI noted below.

**Command:**

```
[:]PROGram[<channel>]:DELeTe[:ALL]
```

### Repeating an Auto Sequence Program:

An Auto Sequence Program can be configured to repeat any number of times or infinitely. The default at power up is to have the repeat count default to once. The program will repeat if the repeat count can be changed using the :PROGram [<channel>] : REPeat command. If a program is running or pause the : PROGram [<channel>] : REPeat command will not work.

**Commands:**

```
[:]PROGram[<channel>]:REPeat {?|<count>|INFinity}
```

Where:

<count> is the repeated count from 1 to 65 534.

INFinity is the character mnemonic for repeating without end.

For Example:

```
:PROG:STAR
*IDN?
*IDN?
:PROG:STOP
```

```
:PROG:REP 2  
:PROG:STAT RUN
```

**The output after the last command might be as follows:**

```
AMETEK, XG (or XTR) 150-5.6, SN# E00123456, 1.00  
Build 10, 21/ 11/2005  
AMETEK, XG (or XTR) 150-5.6, SN# E00123456, 1.00  
Build 10, 21/ 11/2005  
AMETEK, XG (or XTR) 150-5.6, SN# E00123456, 1.00  
Build 10, 21/ 11/2005  
AMETEK, XG (or XTR) 150-5.6, SN# E00123456, 1.00  
Build 10, 21/ 11/2005
```

---

## Configure Other Protection Mechanisms

### Foldback Protection

Foldback protection causes the output of the power supply to shut down if the selected regulation mode is entered and the configured delay time expires. A delay time may be specified as well. The only way to clear foldback is by pressing the rotary Adjust/Enter control for 3 seconds and executing the Clear command.

**Command:**

```
[:]OUTPut [<channel>]:PROTection:CLEar
```

### Setting the Foldback Mode

The following command will set the foldback mode. The mode selected by the character mnemonic sent will indicate which mode will trigger the foldback alarm to begin counting. For example, if the command is sent with the CV mnemonic and the output is enabled with no load attached (open circuit), the unit will operate in constant voltage mode and the foldback counter will begin counting. If the CC mode was set and the output was enabled with no load connected, the unit will operate in CV mode and the foldback counter will not trigger.

**To set the foldback mode, send the command:**

**Command:**

```
[:]OUTPut [<channel>]:PROTection:FOLDback {?|CC|CV|NONE}
```

Where:

NONE indicates foldback protection is disabled.

CC indicates the supply will shut down due to constant current condition.

CV indicates the supply will shut down due to constant voltage.

The default value is NONE.

**To set the foldback delay, send the command:**

**Command:**

```
[:]OUTPut [<channel>]:PROTection:FOLDback:DElay  
<delay_time>
```

Where:

<delay\_time> is a value in the range of 0.5-50 seconds. The unit of second is the default and no units should be used with this parameter. (Increments of 0.1 seconds are allowed.). The default value is 0.5 seconds.

## Over Temperature Protection

The over temperature protection (OTP) is the alarm that protects the unit in case of ventilation blockage, fan failure, or some other event that causes the unit to overheat. The OTP cannot be masked to disable it. The OTP alarm can have its output latch on clearing. See “Alarm Output Latching” on page 3-23.

### The SCPI command (s) for these instructions are:

```
[:]SYSTem[<channel(s)>]:PROTection:LATCh
```

The On setting shown by the front panel (“Using Over Temperature Protection Lock (OTP)” on page 3-30), maps to having the OTP latch flag set. The OFF setting maps to having the OTP latch flag cleared. The default is to have the flag cleared.

## Interlock Enable/Disable

The interlock feature is explained in “Interlock Function” on page 3-33. Use the following command to enable and disable interlock. Enabling interlock will allow the interlock feature to trigger based on the conditions described in “Interlock Function” on page 3-33. This feature can only be controlled using a SCPI command as there is no front panel equivalent. The default value of the interlock is to be disabled.

---

**Important:** The Interlock alarm cannot be masked or latched through the alarm protection mechanisms. It can only be enabled or disabled using the following command.

---

### Commands:

```
[:]SENSe[<channel>]:INTErlock[:STATe] {?|ON|OFF}
```

Where

ON enables the use of interlock protection.

OFF disables the use of interlock protection.



## Save and Recall

The save and recall of user settings can be done using commands as well as at the front panel. Executing the save and recall commands will have the same outcome as following the procedure outlined in “Saving User Setting Memory Locations” on page 3-37 and “Recalling User Setting Memory Locations” on page 3-38.

### Commands:

```
[:]SYSTem[<channel>]:SAVE {<user settings slot>}
[:]SYSTem[<channel>]:RECall {<user settings slot>}
```

Where

<user settings slot> is any integer between 1 and 3. The value corresponds to the setting to be operated on.

## Set Analog Programming Level

Setting the analog programming level is used to define the range from 0 to the level that will be input into the analog programming lines to control the output. The command is equivalent to the procedure described in “Analog Programming Mode” on page 4-9.

### Commands:

```
[:]SYSTem[<channel>]:COMMunicate:APROgram:LEVel
[:VOLTage][:ISOLated] {?|<level>}
[:]SYSTem[<channel>]:COMMunicate:APROgram:LEVel
[:VOLTage] {?|<level>}
[:]SYSTem[<channel>]:COMMunicate:APROgram:LEVel
:CURREnt[:ISOLated] {?|<level>}
[:]SYSTem[<channel>]:COMMunicate:APROgram:LEVel
:CURREnt {?|<level>}
```

Where

<level> is the maximum voltage or resistance that will be input to the analog inputs. The acceptable range is from 2 to 10 V and 2 to 10k $\Omega$ .

## Set Remote Programming Interface

The remote source can be select using the following SCPI commands. These commands are equivalent to the procedure on “Voltage-Controlled Voltage APG Setup” on page 4-10 and “Voltage-Controlled Current APG Setup” on page 4-12.

**Commands:**

```
[:]SYSTem[<channel>]:REMOte:SOURce[:VOLtAge]  
{?:LOCAl|AVOLtAge|ARESiStive}
```

```
[:]SYSTem[<channel>]:REMOte:SOURce:CURREnt  
{?:LOCAl|AVOLtAge|ARESiStive}
```

**Where:**

LOCAl indicates the value is controlled by the set point.

AVOLtAge is used to set the output to be controlled by an analog voltage input.

ARESiStive is used to set the output to be controlled by a resistor circuit.

IAVOLtAge is used to set the output to be controlled by the isolated analog voltage input.

IARESiStive is used to set the output to be controlled by the isolated analog resistor circuit.

## Protection Mask (Enable Alarms)

The protection mask allows for the different alarms to be masked, completely disabling them. This means that the SCPI status and operations registers will not detect the alarms. You will have no way of knowing the current operation state of the alarm. The protection mask is a feature that is only accessible using the SCPI command noted below.

### Command:

```
[:]SYSTem[<channel>]:PROTection[:MASK] {?|<mask>}
```

Where

<mask> is the bit mask for disabling the alarms. See Table 5-19 for details.

**Table 5-19** Alarms Bit Mask

Bit	Bit Weight	Bit Name	Description
0	1	AC Fail	Not used. Always 1.
1	2	OTP	Not used. Always 1.
2	4	Fan Slave	Fan on the slave board (1500W and 1700W models only)
3	8	Fan Stop	Fan on the main board.
4	16	OTP Slave	Over Temperature protection on the slave board (1500W and 1700W models only).
5	32	Interlock	Not used. Always 1.
6	64	OVP	Not used. Always 1.
7	128	OCP	Not used. Always 1.
8	256	Foldback	Foldback protection.
9	512	Shutdown	External Shutdown pin
10	1024	UVP	Under Voltage protection.

See “Alarms and Errors” on page 3-19.

## Power Saving Control (Sleep Mode, XTR/XG 1700 W Only)

The Sleep Mode, supported by the XG/XTR family of DC power supplies, is an effective way to reduce overall power consumption when the power supply is not in use for a specified period of time. If Sleep Mode is enabled, the power supply will revert to a low power consumption mode with the following characteristics:

- Display will be blank
- The internal cooling fans will run at the lowest possible speed for whisper quiet operation.
- Touching any button or one of the rotary knobs will immediately wake up the power supply to normal mode of operation.
- All settings will be preserved during sleep mode and the power supply will return to the previously set state when it wakes up.

The following conditions must be met in order for Sleep Mode to engage:

- The output of the power supply and auxiliary outputs must be off (standby)
- The Sleep Mode must be enabled (on).

### To enable Sleep Mode:

Set a time delay for the duration of inactivity to elapse before entering Sleep Mode. This time (sleep hold-off delay) can be set from the Protection menu, under the SLP entry. The sleep hold off delay can be set from 1 to 24 hours.

### To disable the Sleep Mode:

Set the sleep hold off delay value to zero (0). This is also the default state for the Sleep Mode feature. Thus, unless set from the front panel or remotely using a SCPI command, Sleep Mode is off. Once enabled (set to a value from 1 to 24), it will be enabled. If the set time elapses without any activity on the power supply, it will enter Sleep Mode.

Note that after issuing a \*RST command, the power supply will revert to factory default settings which means Sleep Mode will be turned off.

### Command:

```
[:]SYSTem[<channel>]:PROTection:SLeeP <sleep_time>
```

### Query Format:

```
[:]SYSTem[<channel>]:PROTection:SLeeP?
```

# 6

## Communications Options

Chapter 6, Communications Options, contains information and procedures for setting up and programming XG/XTR 850 Watt power supply models with the MEA option for LAN/Ethernet Interface, and for XG/XTR 1500 Watt and 1700 Watt power supply models with the MEB option for LAN/Ethernet Interface.

## INTRODUCTION

This chapter contains setup and programming information for the XG/XTR Series power supply for operation through a LAN/Ethernet connection. Instructions for 850 Watt models with the MEA option, including Troubleshooting, are presented first, followed by instructions for 1500 Watt and 1700 Watt models with the MEB option.

The information presented here will guide you in making the connections necessary to control your power supply remotely.

## SETTING UP XG/XTR 850 WATT MODELS

This section is intended for network administrators responsible for the configuration and maintenance of devices on the network. It provides information for connecting and configuring the power supply with the MEA option.

### Basics

This section describes the equipment and procedures to fully set up the simplest configuration of an XG/XTR 850W unit with the ENET option and a single computer.

---

**Important:** The remote interface that was previously configured when the local lock setting was activated will still be available for remote control while the front panel is locked.

---

### System Requirements

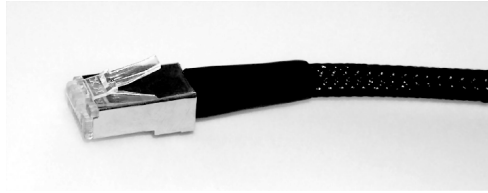
- Windows XP, Windows 2000, Windows NT4.0 (with service pack 6.0a or later), Windows ME, or Windows 98
- Internet Explorer 5.01 or later
- 30 MB hard drive space
- 64 MB RAM

### Accessories

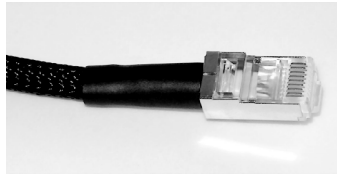
- Power supply with ENET port
- ENET RJ-45 and RJ-45 STP, Cat 5 cross-cable
- PC
- Installation CD

### Communication Cable

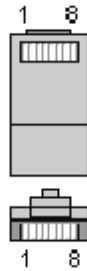
Use a standard RJ-45 (see Figure 6-1) and RJ-45 cross-cable (see Figure 6-2).



**Figure 6-1 Computer or HUB Plug**



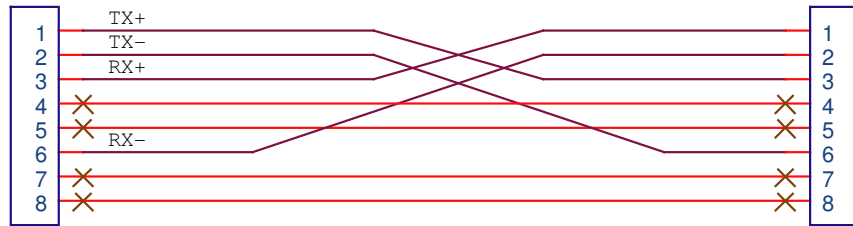
**Figure 6-2 Power Supply Plug**



**Figure 6-3 RJ-45 Plug**

**Table 2-1 Description of Pins on RJ-45 Plug**

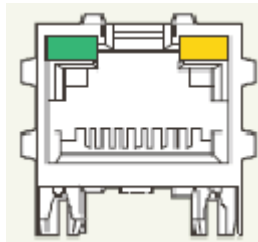
<b>Pin#</b>	<b>Name</b>	<b>Description</b>
1	TX+	Transmit data +
2	TX-	Transmit data -
3	RX+	Receive data +
4	Gnd	Ground
5	Gnd	Ground
6	RX-	Receive data -
7	Gnd	Ground
8	Gnd	Ground



**Figure 6-4 Scheme of ENET Cross-Cable**

### ENET Connector

The XPort® ENET connector is located on the rear panel of the power supply. See Figure 6-5. At the top left corner is the link LED, and at the top right corner of the connector is the activity LED. See Table 6-2 for a description of their colors and what each indicates.



**Figure 6-5 XPort® ENET Connector and LEDs**

### XPort™ LEDs

The device contains two bi-color LEDs built into the front of the XPort™ connector. See Figure 6-5.

Table 6-2 Description of LEDs

LED	Color	Description
Link LED (Left side)	Off	No link
	Amber	10 Mbps
	Green	100 Mbps
Activity LED (Right side)	Off	No activity
	Amber	Half-duplex
	Green	Full-duplex



## Network Topology and Connection

The following section describes the network topology for the single computer and single XG/XTR power supply unit. The other possible network topologies will be discussed later in the “Advanced Section” on page 6-24. The additional topologies build on the configuration ideas present in this section by referencing the various setup instructions.

### Single Computer and Single Power Supply Unit

Figure 6-6 shows the connection between the ENET unit and Local Computer through a crossover cable; however, a HUB could also be used with straight through Ethernet cables as well. Connect your computer to the ENET as shown in Figure 6-6, or if this topology does not match your configuration, refer to the “Advanced Section” on page 6-24 to identify the topology you wish to implement and follow the instructions described in that section.

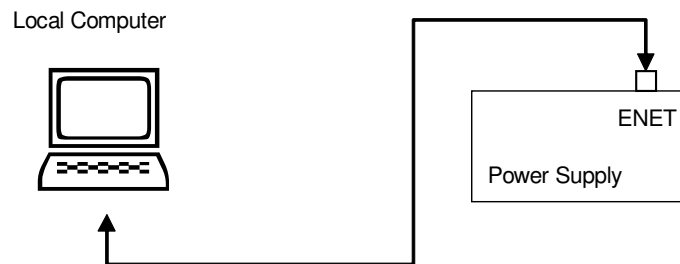
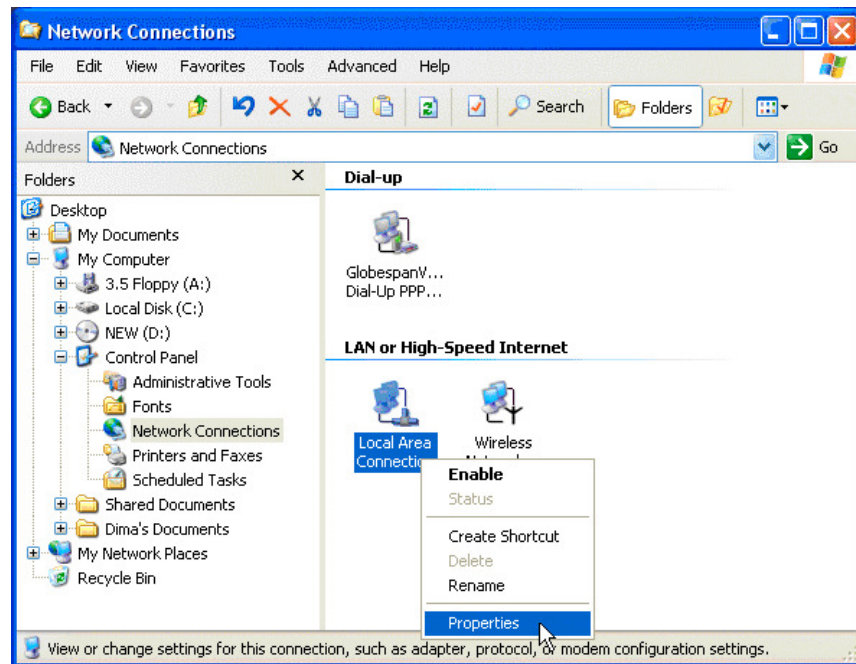


Figure 6-6 Single Computer, Single Power Supply

### Setting Up the Computer

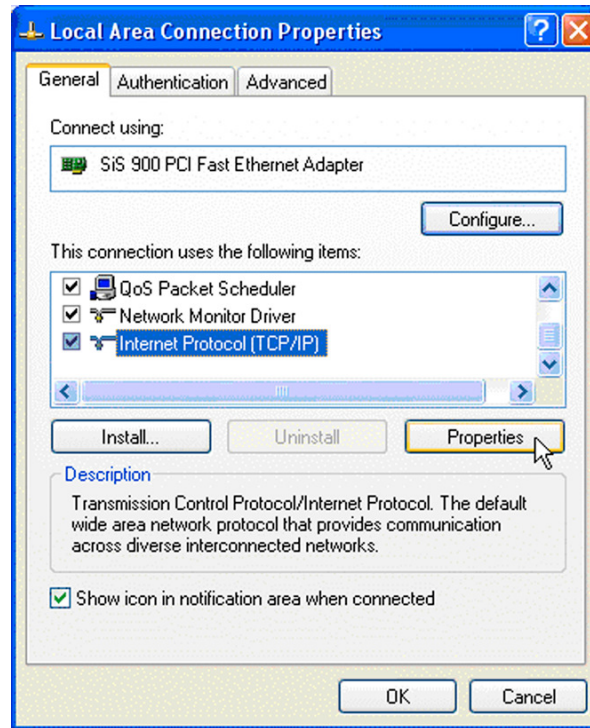
#### To set up the computer:

1. Open Explorer on the main computer, go to Control Panel > Network Connections > Local Area connections. See Figure 6-7.



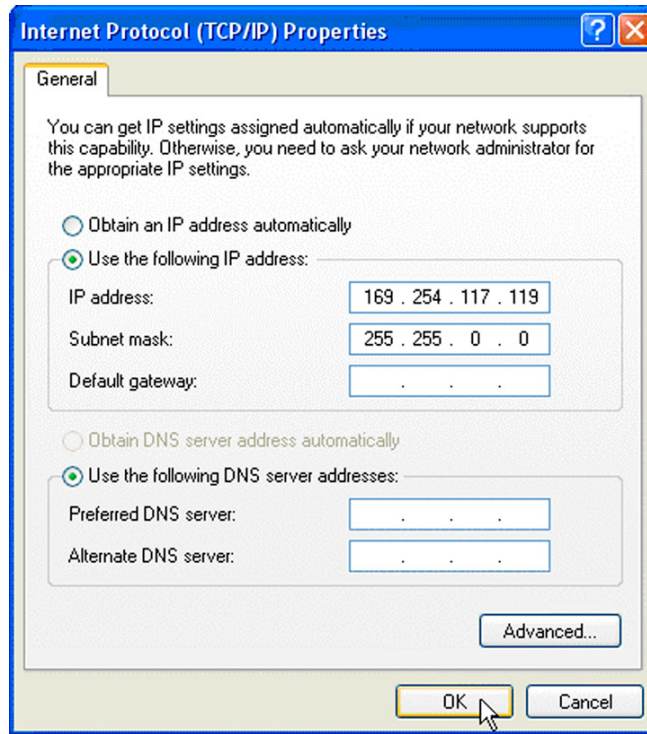
**Figure 6-7 Configuring the Network Connection of the Computer**

2. Right click on the mouse button and click on Properties.  
The Local Area Connection Properties window appears. See Figure 6-8.



**Figure 6-8 LAN Properties Dialog Box**

3. Click the Internet Protocol (TCP/IP) check box and click Properties. See Figure 6-8.  
The Internet Protocol (TCP/IP) Properties Dialog Box appears. See Figure 6-9.



**Figure 6-9 Internet Protocol (TCP/IP) Properties Dialog Box**

4. Click on Use the following IP address option and type the appropriate IP address in the box, or select the Obtain an IP address automatically setting if your network is configured using DHCP.
5. Click OK.

## Software Installations

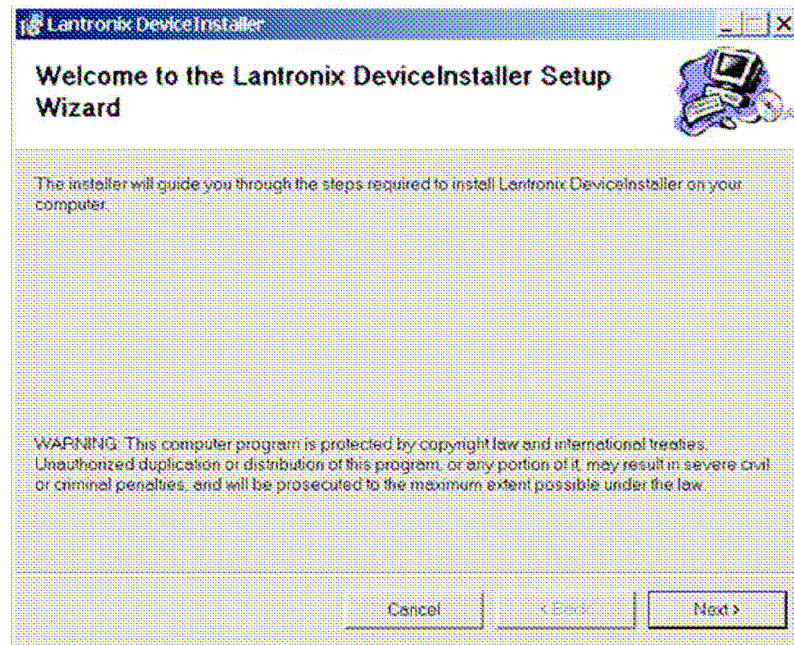
To set up the ENET option card, the Lantronix® DeviceInstaller program needs to be installed on your PC. DeviceInstaller is an all-in-one utility for setting up various Lantronix devices on a network. Device Installer auto detects any devices on the network and allows for configuration of network settings. As a management tool, the DeviceInstaller allows for device monitoring and status verification of the ENET option card.

**To install the DeviceInstaller:**

1. Insert the DeviceInstaller CD into the CD ROM drive.

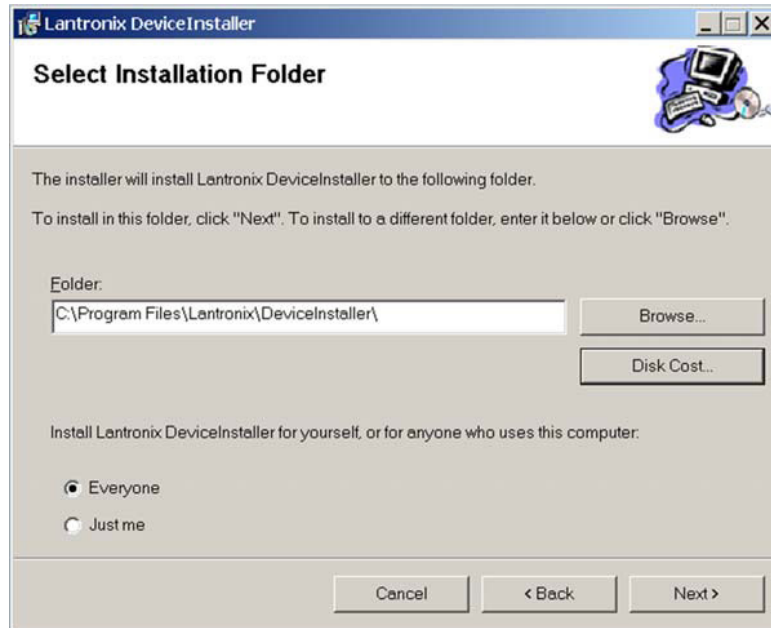
The CD should launch automatically.

If you need to manually launch the CD, click the Start button on the Task Bar and select Run. Enter the CD drive letter, for example, D:\Launch.exe. The DeviceInstaller Setup Wizard opens to guide the installation process. See Figure 6-10.



**Figure 6-10 DeviceInstaller Setup Wizard**

2. Click Next to open the Select Installation Folder window.  
The Select Installation Folder window prompts for a destination folder for the installation.



**Figure 6-11 Select Installation Folder Window**

3. Click Next to begin the installation.  
The Installation Complete window displays when the installation is finished.
4. Click Close to exit.

## Configuring the Device Using DeviceInstaller

The DeviceInstaller displays a list of the XG/XTR units with the ENET option that are on the network. When the DeviceInstaller initially starts, the device list is empty. Devices may be added by performing a search for the devices on the network or by adding them manually.

### Selecting a Network Adapter

After the installation of DeviceInstaller to your PC, you must select which network adaptor you wish the DeviceInstaller to use for all its network communications.

**To select the network adaptor:**

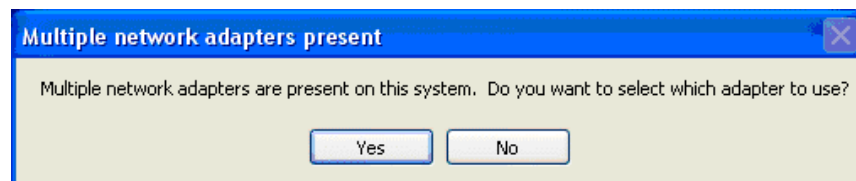
1. Start DeviceInstaller by clicking Start > All Programs > Lantronix > DeviceInstaller > DeviceInstaller.
2. If this is the first time you have started the program after installing it and there are more than one network adaptors on the PC, you might be prompted to select the network adaptor as seen in Figure 6-12. If this prompt does not appear, click Tools > Options... to bring up the Options window shown in Figure 6-13.
3. Verify that the network adaptor that is connected to the network that you are running your XG/XTR unit(s) on, is selected.

---

**Important:** Only network adaptors that are enabled and have an Ethernet cable connected will be shown in this list. If one of your networks adaptors is not shown in this list, verify that it is enabled and has a network cable connected to it.

---

4. Click the OK button.



**Figure 6-12 Multiple Network Adapters**

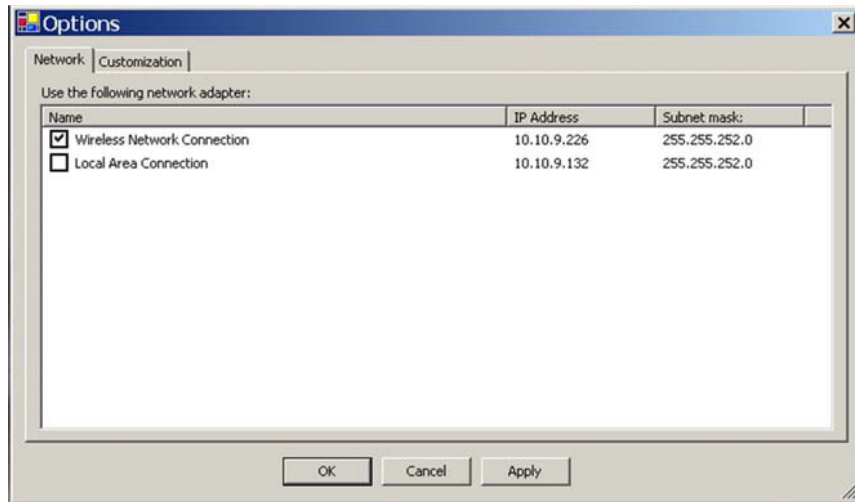


Figure 6-13 Selecting Network Adapter

### Assigning an IP Address to the Power Supply Unit

If your system is auto-IP configured, the following warning message is displayed:

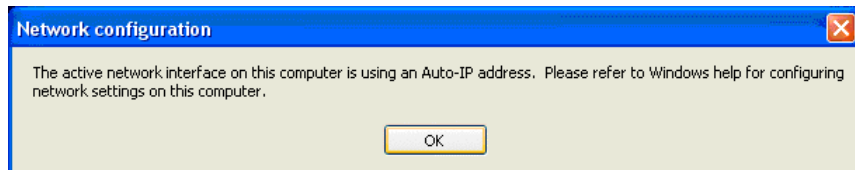


Figure 6-14 Auto-IP Address Message

---

**Important:** Auto-IP mode is acceptable only for the single computer and single power supply configuration.

---

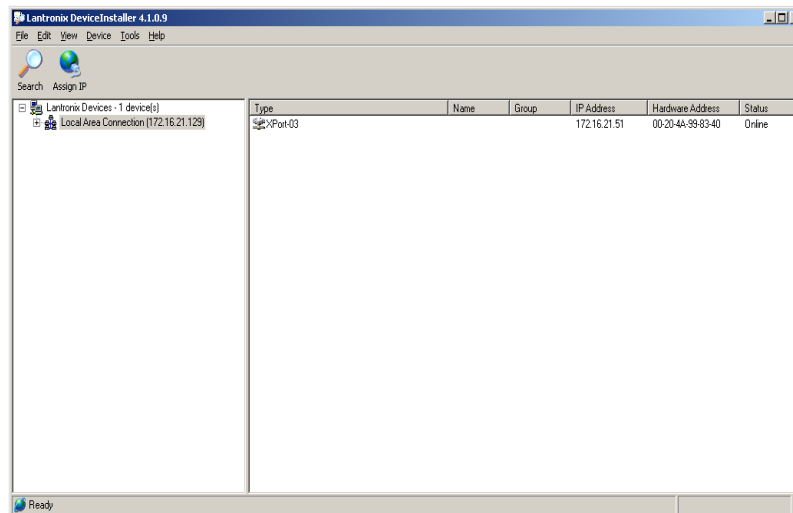
#### To assign an IP address to the power supply unit:

1. Click OK to dismiss the Auto-IP warning message. If you are not intending on using an Auto-IP, debug your network connection at this time.

The Lantronix DeviceInstaller window appears. See Figure 6-15.

2. Click Search to get a list of all the XG/XTR devices that can be reached from the network adaptor that you previously selected. If your XG/XTR unit(s) are powered up, they should appear in this list.





**Figure 6-15 Searching for Power Supply IP Address**

After a short delay, your power supply will be found. See Figure 6-15. If the power supply is not found or the found device is not reachable, contact your network administrator for details about network settings.

3. If the IP address shown and the method that the XG/XTR unit is using to obtain this address is correct, stop here and exit/close this window. Otherwise, continue to step 4.
4. Expand the Local Area Connection tree; if necessary, expand further until the IP address of the XG/XTR unit is displayed. Then left click the IP address; the screen should display as shown in Figure 6-16.

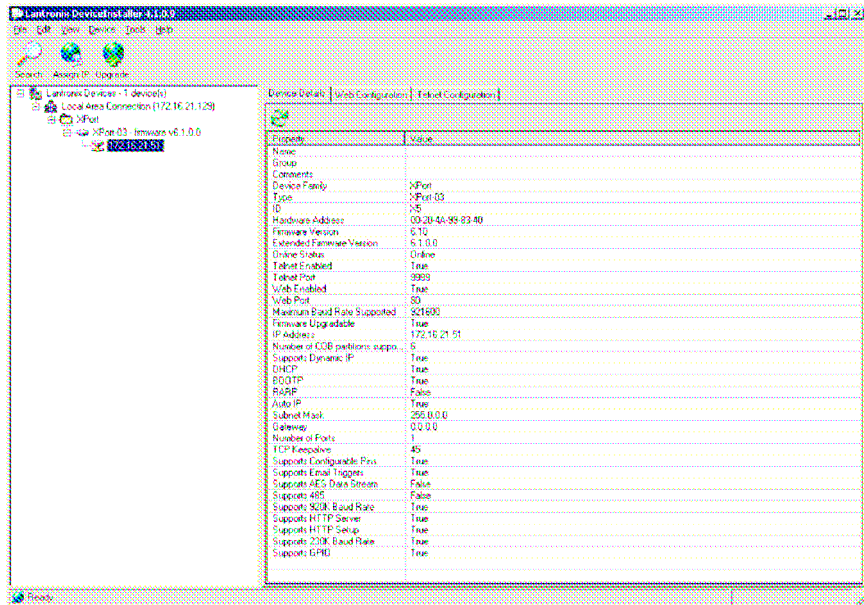


Figure 6-16 IP Address Details Window

**Important:** Do NOT use the Assign IP button in the tool bar, upper left of this window. The IP address is assigned using Steps 5 through 9 that follow.

- In this window, click the Web Configuration tab, which will open a new window. See Figure 6-17.

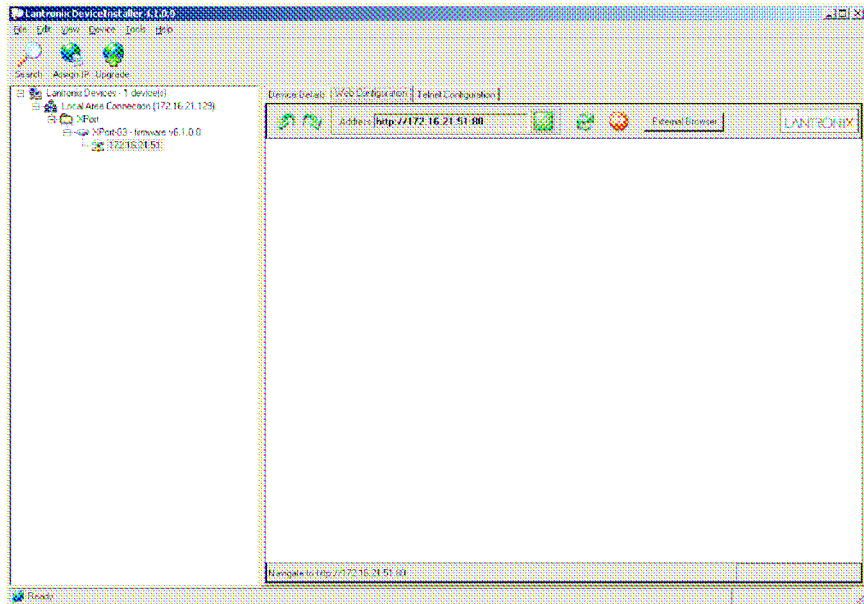
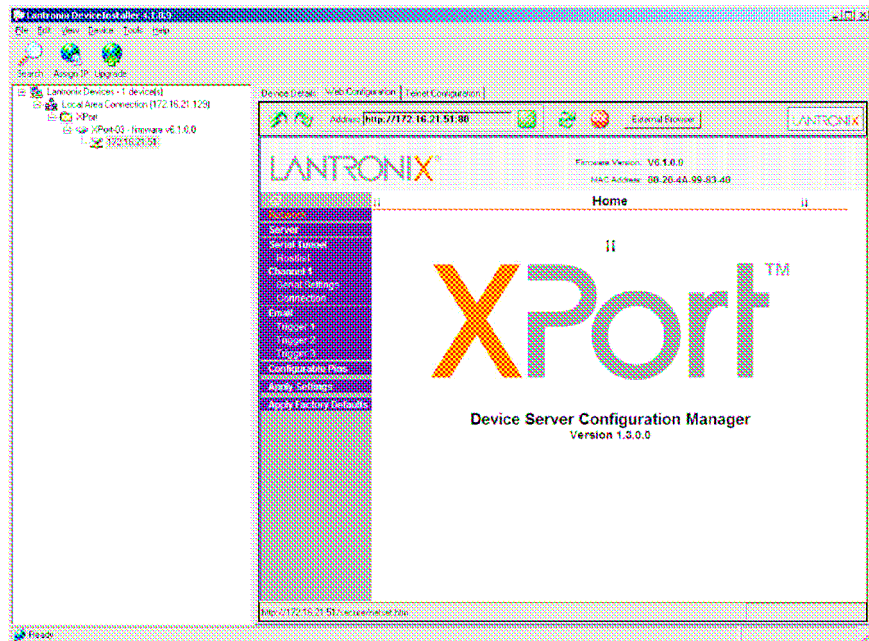


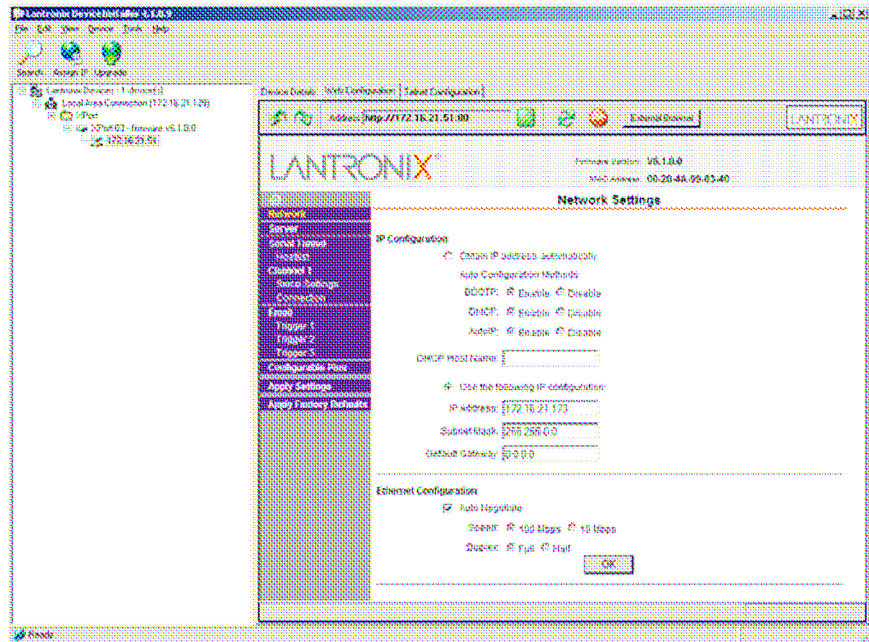
Figure 6-17 Entering the Lantronix Interface

6. Next to the Address field, click the green Go button.
7. You will be prompted for user name and password: ignore these fields (leave blank) and click OK. This brings up the Lantronix XPort® interface (Figure 6-18).



**Figure 6-18 Lantronix XPort® Interface**

8. At the top of the sidebar menu click Network. See Figure 6-19.



**Figure 6-19 Assigning IP Settings**

9. In the IP Configuration section, click the radio button next to “Use the following IP configuration.”

---

**Important:** If you are working within a network system, please contact the network administrator for the appropriate information to complete the IP Address, Subnet Mask and Default Gateway fields.

---

10. Click OK at the bottom of the page to complete the task.
11. Repeat this procedure for every power supply. Every device must have a unique fixed IP address.

### Selecting ENET as the Communication Port

Once the XG/XTR unit with the ENET option has the option card configured, you’ll need to configure the XG/XTR to use the ENET option card as the active communication port.

#### To select ENET as the communication port:

1. Turn the 9-position Mode control to PGM.  
rE is displayed in the output voltage display.
2. Turn the rotary Adjust/Enter control to select the LAN communication port.
3. Press the rotary Adjust/Enter control.

*Addr* is displayed on the output voltage display.

4. Turn the rotary Adjust/Enter control to select the desired address between 1 to 30.
5. Press the rotary Adjust/Enter control to commit the new address.

## Terminal Configuration

The terminal program allows for communication with the power supply. To use a terminal program, set it up using the parameters from the following sections. If you wish to use HyperTerminal, see “Setting Up a HyperTerminal Connection” on page 6-17 for instructions.

### Data Format

Serial data format is 8 bit, one stop bit. No parity bit. Flow control: none.

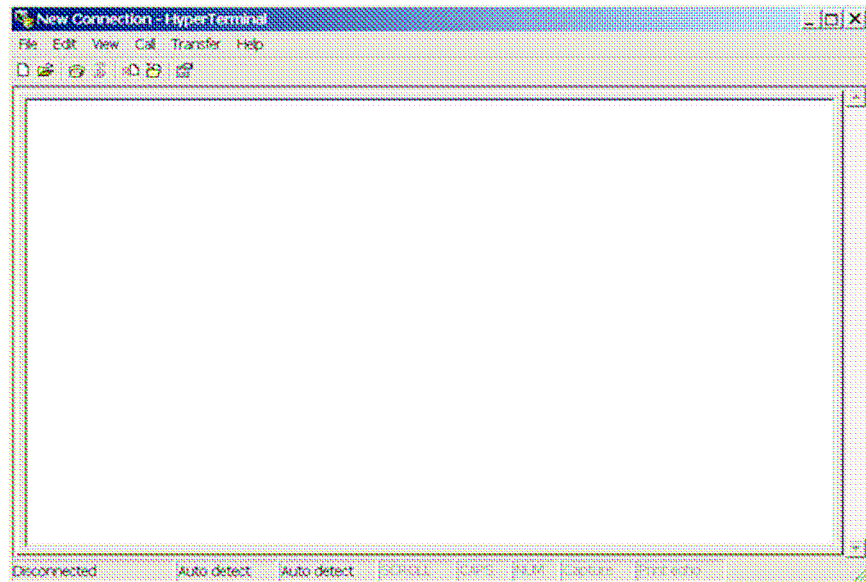
### End of Message

The end of message is the Carriage Return character (ASCII 13, 0x0D). The power supply ignores the Line Feed (ASCII 10, 0x0A) character.

## Setting Up a HyperTerminal Connection

### To set up a HyperTerminal connection:

1. Start Windows HyperTerminal by clicking Start > All Program > Accessories > Communications > HyperTerminal.  
See Figure 6-20.



**Figure 6-20 HyperTerminal Connection**

2. Click New to create a new connection.

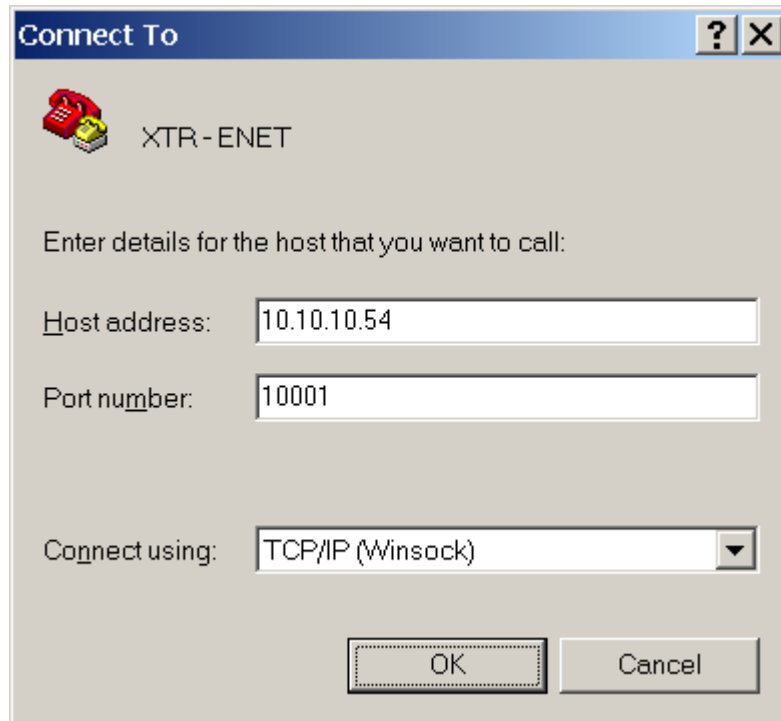
The Connection Description window appears. See Figure 6-21.



**Figure 6-21 Connection Description Window**

3. Enter the name of the connection and select the icon.
4. Click OK.

The new connection setup dialog box will appear (Figure 6-22).

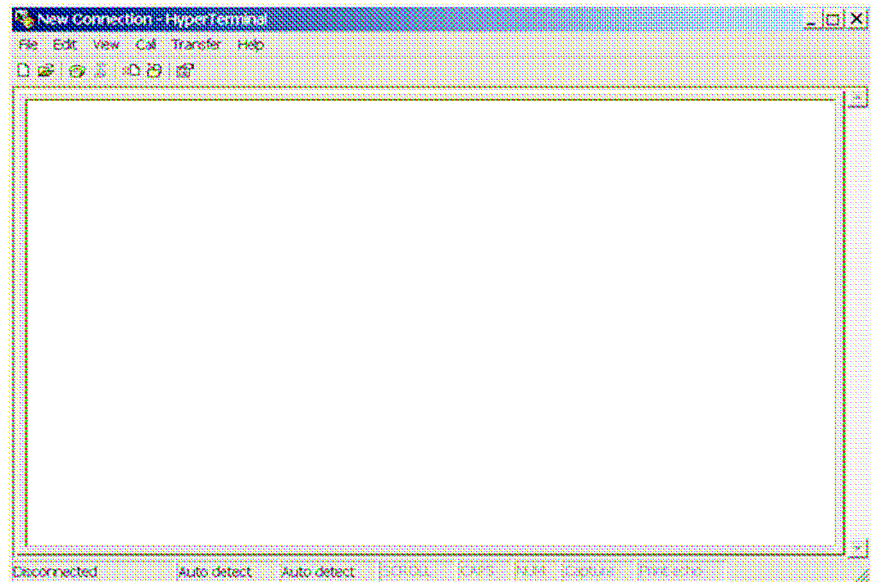


**Figure 6-22 New Connection Dialog Box**

5. In the Connect using: box, select “TCP/IP (Winsock)”.
6. In the Host address box, enter the IP address, obtained in step 14 of the section entitled “Assigning an IP Address to the Power Supply Unit” on page 6-12.
7. In the Port number box, enter “10001” as the value.
8. Click OK.

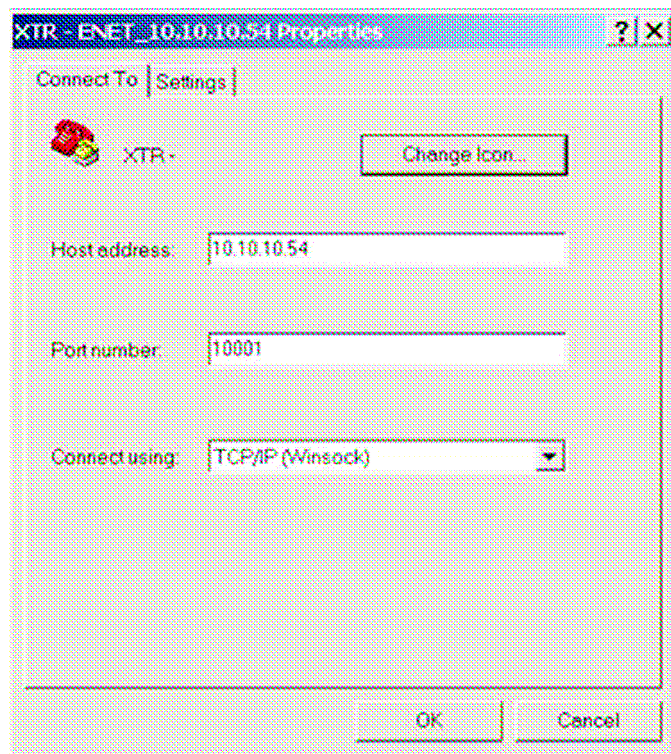
**To specify the terminal connection properties:**

1. Click Disconnect if necessary, and click Properties in the main HyperTerminal window. See Figure 6-23.



**Figure 6-23 Main Terminal Window**

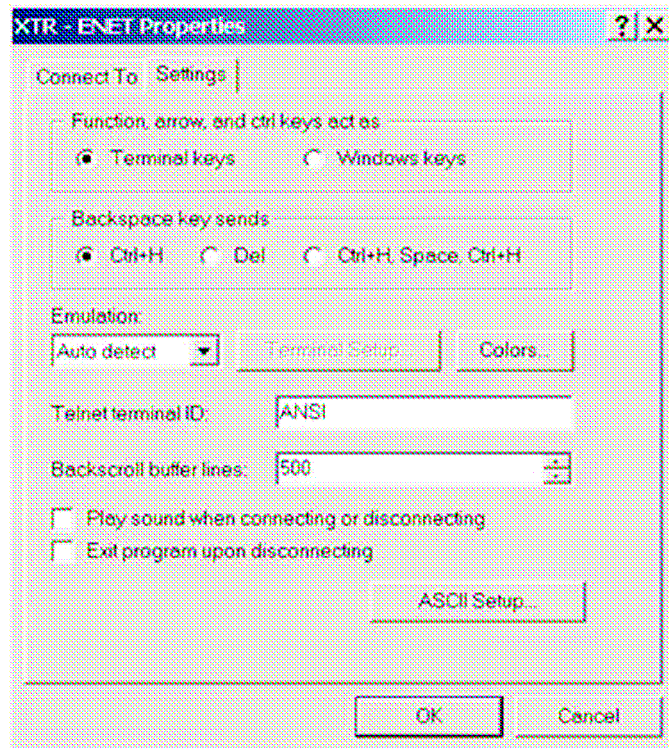
2. In the ENET Properties window, click on the Settings tab. See Figure 6-24.



**Figure 6-24 ENET Properties Window**



The Properties dialog box appears. See Figure 6-25.



**Figure 6-25 XTR-ENET Properties Dialog Box**

3. Click the ASCII Setup button.  
The ASCII Setup dialog box will appear as shown in Figure 6-26.
4. Verify that the ASCII Sending and ASCII Receiving boxes are checked as shown in Figure 6-26.

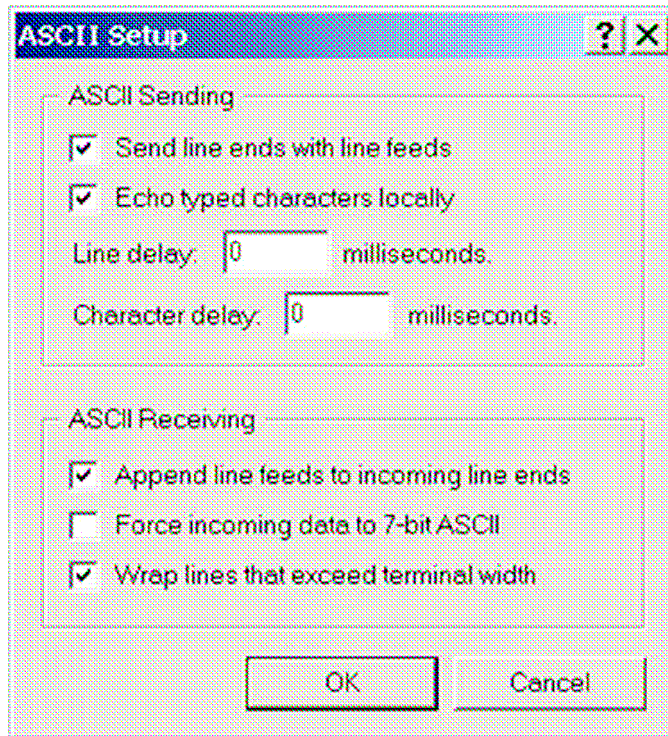


Figure 6-26 ASCII Setup Dialog Box

5. Click OK.

## Establishing Communication with the Power Supply

### To establish communication with the power supply:

1. In the main HyperTerminal window, click Call. See Figure 6-27.
2. To verify that the XG/XTR unit is connected and functioning, type the following command "`*ADR <#>;*IDN?`" where the `<#>` should be replaced by the address assigned to the power supply in the "Selecting ENET as the Communication Port" on page 6-16.
3. Verify that the XTR unit responds with the ID string.
4. To save your session for future use, click File > Save As.... See Figure 6-28.

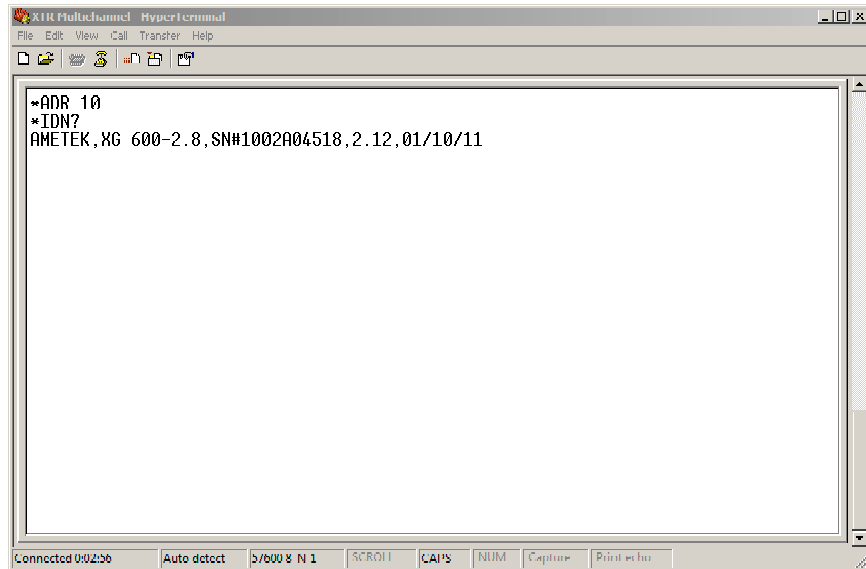


Figure 6-27 Main HyperTerminal Window

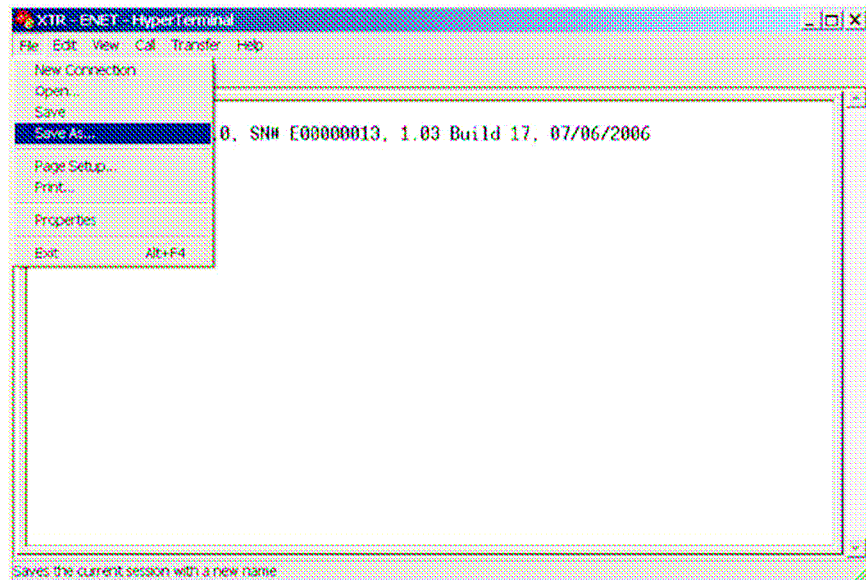
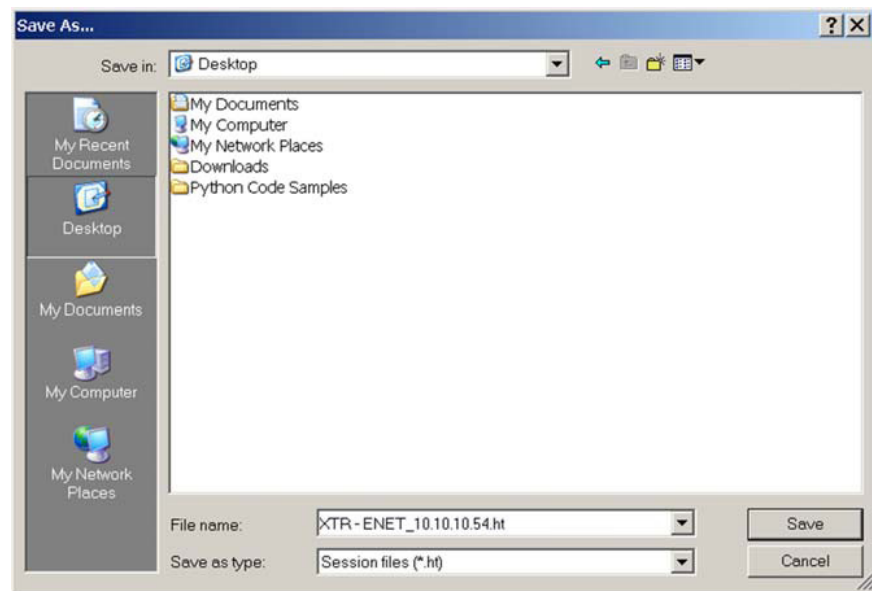


Figure 6-28 Saving Session

5. Type the name of the session. It is recommended that you include the IP in your naming convention so that it is clear which power supply you are connecting to.
6. Click Save.



**Figure 6-29 Saved Session**

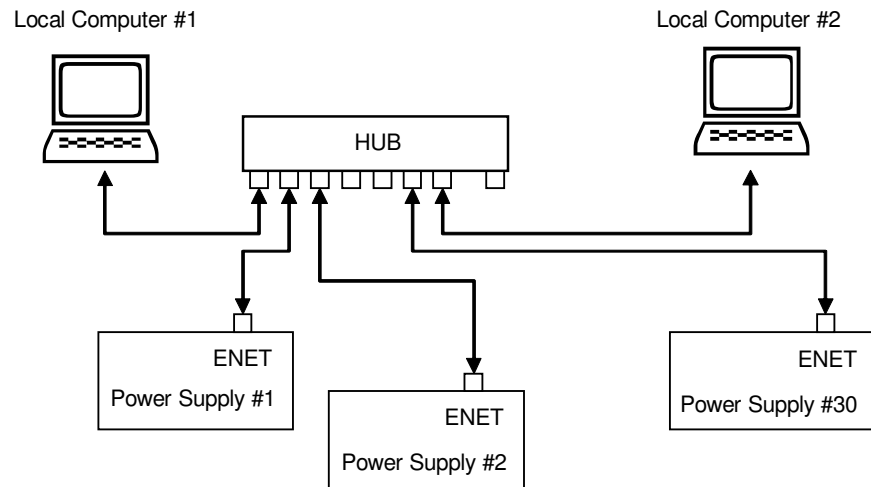
Congratulations! Your network is installed and functioning properly.

## Advanced Section

The advanced section describes the setup and connection for various network topologies involving multiple power supplies.

### Network Topology 1: Simple LAN

The simple LAN topology is the most common configuration for setting up the ENET option on the XG/XTR. The topology follows the typical star topology provided by a HUB and multiple XGs/XTRs with the ENET option and one or more computers. Figure 6-30 shows this configuration.



**Figure 6-30 Multiple Power Supplies and Two Computers**

All devices connect via the HUB. Every device must have a unique IP address, for example:

- Computer #1: 169.254.117.231
- Computer #2: 169.254.117.232
- Power supply #1: 169.254.117.220
- Power supply #2: 169.254.117.221
- Power supply #3: 169.254.117.222
- Power supply #30: 169.254.117.230.

You must set up every device manually.

**To set up for multiple power supplies and two computers:**

1. Set up your computer as described in “Setting Up the Computer” on page 6-5. Repeat the procedure for each computer hooked up to the system.
2. Install the DeviceInstaller software on the PC you wish to use to configure the XG/XTR unit (s) with. See the instructions for “Software Installations” on page 6-8.
3. Configure each XG/XTR unit with an ENET option. See the instructions for “Configuring the Device Using DeviceInstaller” on page 6-10.
4. Create terminal connections for each of the XG/XTR unit (s) with the ENET option that were configured in step 3. See the instructions for “Terminal Configuration” on page 6-17.

5. If more than one computer is going to be used, copy the filename.ht files saved in step 3 to a disk and copy them over to each computer that you will be using to access the XG/XTR unit (s) over the Ethernet. If copying the files is not possible, repeat step 3 for each computer that you wish to use.

The configuration is complete. You are now ready to use your system.

### Controlling Your System

For every connected XG/XTR unit, create a separate terminal session. This should have been done according to the instructions in “Establishing Communication with the Power Supply” on page 6-22. Also, open a separate HyperTerminal session for each XG/XTR unit that you wish to control. An example of two units in a system is shown in Figure 6-31.

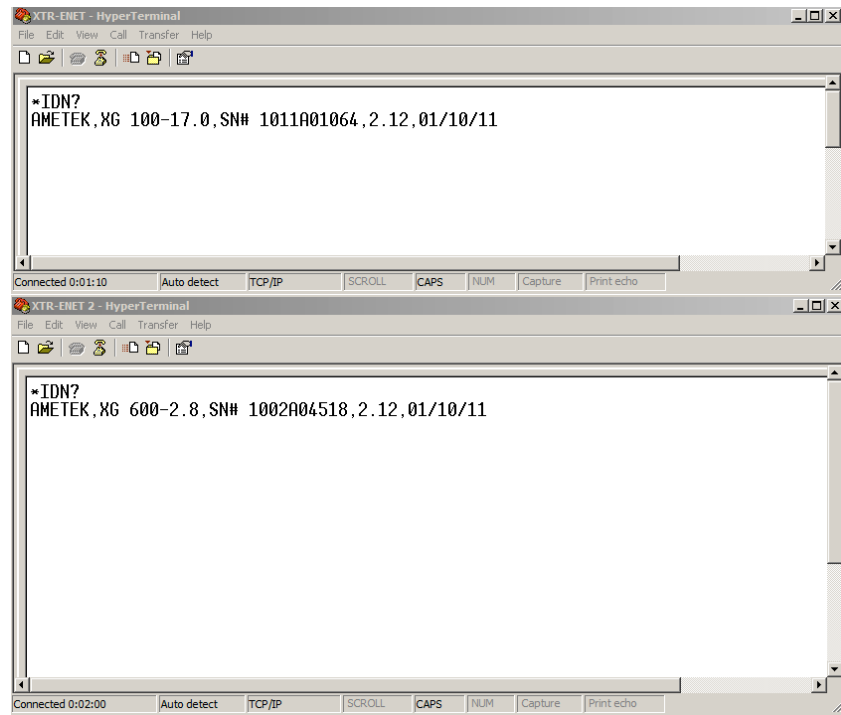
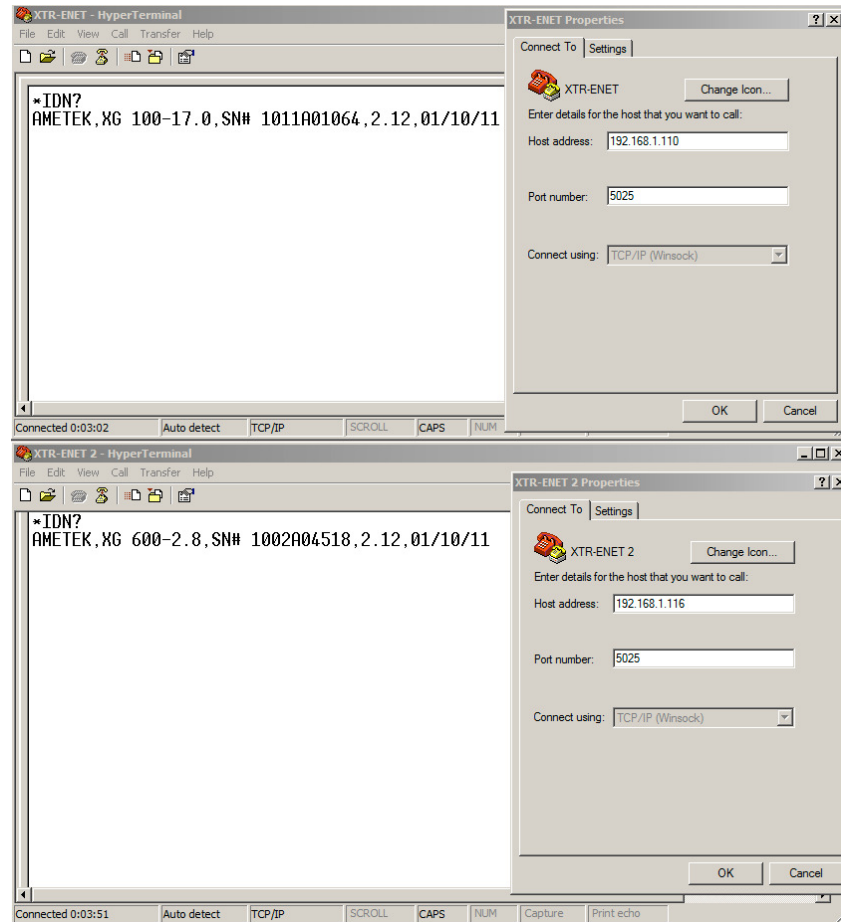


Figure 6-31 HyperTerminal Session

There are two HyperTerminal windows for controlling two power supply units. See Figure 6-31.



**Figure 6-32 System with Two Connected Devices**

Figure 6-32 shows a system with two connected devices.

---

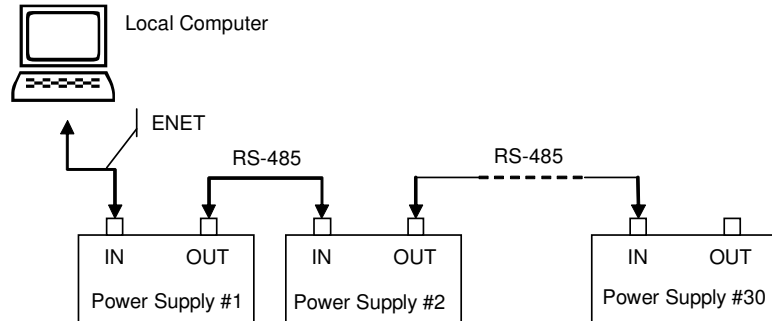
**Important:** In this system configuration, every power supply needs a unique IP address, whereas the address defined from front panel (power supply’s own address) may be arbitrary.

---

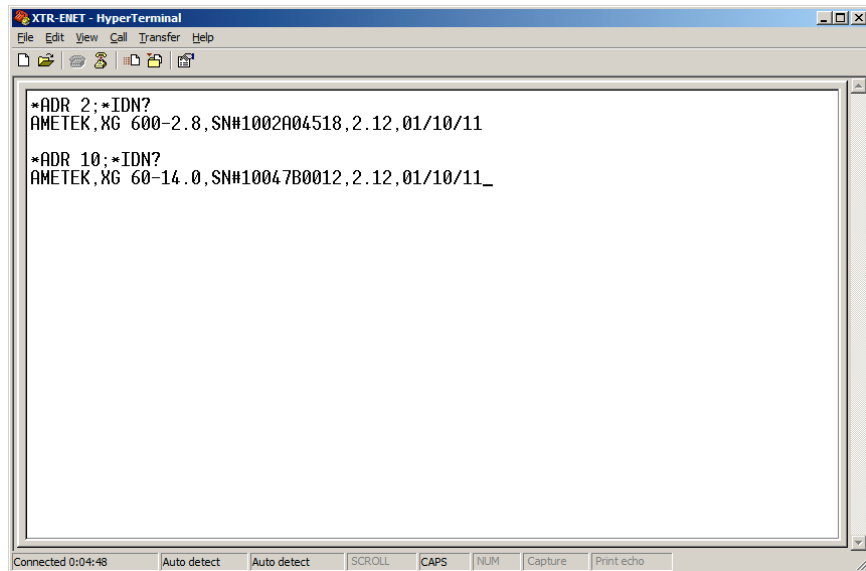
## Network Topology 2: ENET and RS-485 Bus

Up to 30 units may be connected to the RS-485 bus. The first unit connects to the controller via ENET, and the other units are connected with the RS-485 bus.

Figure 6-33 shows the system of a unit with the ENET option and several units connected via the RS-485 bus. Each power supply must have its own address, defined from the front panel. Only one IP address is required for your network (excluding computers) and only one controlling program is required (one per unit with ENET option as noted in “Network Topology 1: Simple LAN” on page 6-24).



**Figure 6-33 ENET and RS-485 Bus**



**Figure 6-34 HyperTerminal Window**

Figure 6-34 shows the HyperTerminal session for the combined configuration which is an ENET and RS-485 network. This figure also shows access to power supplies #2 and #10 sequentially.



## Setting Up Your System

### To set up your system:

1. Connect your system as shown in Figure 6-33, and turn every power supply unit to ON.
2. Set up your computer as described in “Setting Up the Computer” on page 6-5. Repeat this section for each computer hooked up to the system.
3. Install the DeviceInstaller software on the PC you wish to use to configure the unit (s) with. See the instructions for “Software Installations” on page 6-8.
4. Configure the ENET card of the master unit (power supply #1 in Figure 6-33). See the instructions for “Configuring the Device Using DeviceInstaller” on page 6-10.
5. Configure the master power supply which is the unit with the ENET option (power supply #1 in Figure 6-33) by following the instructions in “Selecting ENET as the Communication Port on page 6-16.
6. The following Steps 7, 8 and 9 must be repeated for each slave unit:
7. For the slave unit that you are setting up, turn the 9-Position Mode Control Knob to PGM.  
rE is displayed in the output voltage display.
8. Turn the rotary Adjust/Enter control to select SLA and press the rotary Adjust/Enter control.
9. Set a unique address and press the rotary Adjust/Enter control. Once all slave units have been setup, proceed with the next step.
10. Set up the fixed IP address for the first unit using DeviceInstaller as described in “Assigning an IP Address to the Power Supply Unit” on page 6-12.
11. Create and set up a new HyperTerminal session as described in “Terminal Configuration” on page 6-17.
12. In the HyperTerminal session window, type the \*ADR <#>;\*IDN? command where the <#> should be replaced by the address assigned to the power supply in step 9. Press enter to send the command.
13. Verify that the unit responds with the ID string. Perform this test for each unit that is connected including the master unit.

14. If additional XG/XTR units are using Network Topology 2, repeat the setup procedure steps 1 to 14 for each ENET and RS-485 group.

---

**Important:** The IP address for each ENET and RS-485 group must be unique, but the RS-485 bus addresses can be reused for each unique ENET – RS-485 group.

---

## Troubleshooting for XG/XTR 850W Model with ENET and/or RS-485 Communication

This section describes specific troubleshooting for the combined ENET – RS-485 communication only, followed by typical troubleshooting procedures for connecting and setting up ENET communications.

### Troubleshooting for the Combined ENET – RS-485 Communication

Symptom	Check	Action
One of the power supply units is not responding.	The power supply is not turned on.  The communication interface is not set as a slave unit (RS-485) or the address has not been set correctly.	Turn the power supply ON.  Check that the RS-485 bus is selected as the communication interface and the address is correct.
Sequentially several units are not responding, e.g. from #21 to end.	RS-485 communication is disconnected at the first unit that is not responding.	Check your RS-485 communication. Try switching the cable linking this unit to the last unit that is known to have given a response.
All of the units are not responding.	The ENET communication is disconnected.  The HyperTerminal session is not configured properly.	Check the ENET communication.  Check the settings of the HyperTerminal session. Follow the instructions in the “Selecting ENET as the Communication Port” on page 6-16.

**Troubleshooting for ENET Communication**

<b>Symptom</b>	<b>Check</b>	<b>Action</b>
DeviceInstaller does not detect your device.	<p>Your ENET cable is not a cross cable.</p> <p>Power supply is not turned on.</p> <p>The network that your computer is on cannot reach the network that the unit with the ENET option is connected to.</p> <p>DeviceInstaller is not configured to use the Ethernet card on your computer that is connected to the network which has the unit with ENET option on it.</p>	<p>Use the correct ENET cross cable.</p> <p>Turn the power supply ON.</p> <p>Connect a laptop to the HUB or to the switch that the unit with the ENET option is connected to, and ping the computer you are trying to use DeviceInstaller on. If no response is seen, then contact your network administrator and find out if ICMP requests are being filtered on the network and a possible reason for not being able to contact the computer.</p> <p>See “Selecting a Network Adapter” on page 6-10.</p>
Found device is not reachable.	Your network is not configured properly.	Contact your network administrator.
Typed text is not visible.	Echo mode is not active.	Select Echo typed characters locally in the ASCII Setup dialog box of HyperTerminal.
The power supply is not responding.	The communication port on the power supply unit is not selected properly. The address of the power supply unit is not valid. The address has not been selected using the *ADR <address>.	Select “ENET” as the communication port. Refer to the correct power supply address using the front panel.

## SETTING UP XG/XTR 1500 and 1700 WATT MODELS

This section is intended for network administrators responsible for the configuration and maintenance of devices on the network. It provides information for connecting and configuring the power supply with the MEB option.

### LOCAL AREA NETWORK (LAN) OPTION

All power supplies functions are programmable over the LAN (Ethernet) interface if the ENET/LAN option is installed (specified at the time of order) The ENET/LAN interface, which operates with auto detection, supports 10Base-T, 100Base-T and 1000Base-T.

Using LAN allows remote communication with the instrument; it is fast, simple and the LAN from your PC does not require any additional proprietary software or cards.

### Media Access Control (MAC) Address

Each power source with the LAN option installed has a unique network address known as the MAC address, a unique hexadecimal address, which is listed on a rear panel label of the power source. To operate the power source on a network, this MAC address needs to be assigned to a TCP/IP address, which will be used to address the device on the network.

### Communication Configuration

Presented here are three connection choices for remote control of the instrument:

- through a local area network (LAN)
- direct to a PC
- through a private network.

Each requires an IP address; the LAN also requires a Gateway address. The addresses can be set automatically through a Dynamic Host Configuration Protocol (DHCP) server or set manually with a static IP address.

### LAN Connection

Connect the instrument directly to a network Ethernet port with a LAN cable, and allow the DHCP server to automatically assign a dynamic IP and Gateway address. If DHCP is not enabled, see the

section on SETTING LAN PARAMETERS in this chapter or contact your network administrator.

## Direct-to-PC Connection

Connect the instrument directly to a PC LAN port with a crossover cable (similar to an Ethernet cable but wired differently to enable direct connection rather than through a network). Next, establish an IP address for the instrument. You can assign a static IP address by using the same address as the PC that the instrument is connected to. To find the PC's IP address, use the "ipconfig.exe" command per in the section on Private Network Connection next.

## Private Network Connection

A private network has no DHCP server; therefore, the instrument would be connected to a Windows PC with a crossover cable, and manually assigned a static IP address matching that of the PC. The available IP address range assigned by the Internet Assigned Network Authority (IANA) for Automatic Private IP Addressing (APIPA) is 169.254.0.0 to 169.254.255.255.

When setting up a private network, you will have to log off and disconnect first from any network connection and re-log in to Windows.

To check the PC's IP address, run the "ipconfig.exe" program from the command prompt. The screen on a private network should look as follows:

```
Microsoft(R) Windows DOS
(C)Copyright Microsoft Corp 1990-2001.

C:\>ipconfig

Windows IP Configuration

Ethernet adapter Local Area Connection:

    Connection-specific DNS Suffix  . :
    IP Address. . . . . : 169.254.0.208
    Subnet Mask . . . . . : 255.255.0.0
    Default Gateway . . . . . :
```

To determine what IP address to use, use the first 2 octets (in the above case "169.254") of the PC's IP address and set a unique value for the third and fourth octet as long as there are no conflicts with any other IP addresses (other instruments) on the same private network. In this example, 169.254.0.209 would work.

Note: For private network configurations, no Gateway address is required. (0.0.0.0)

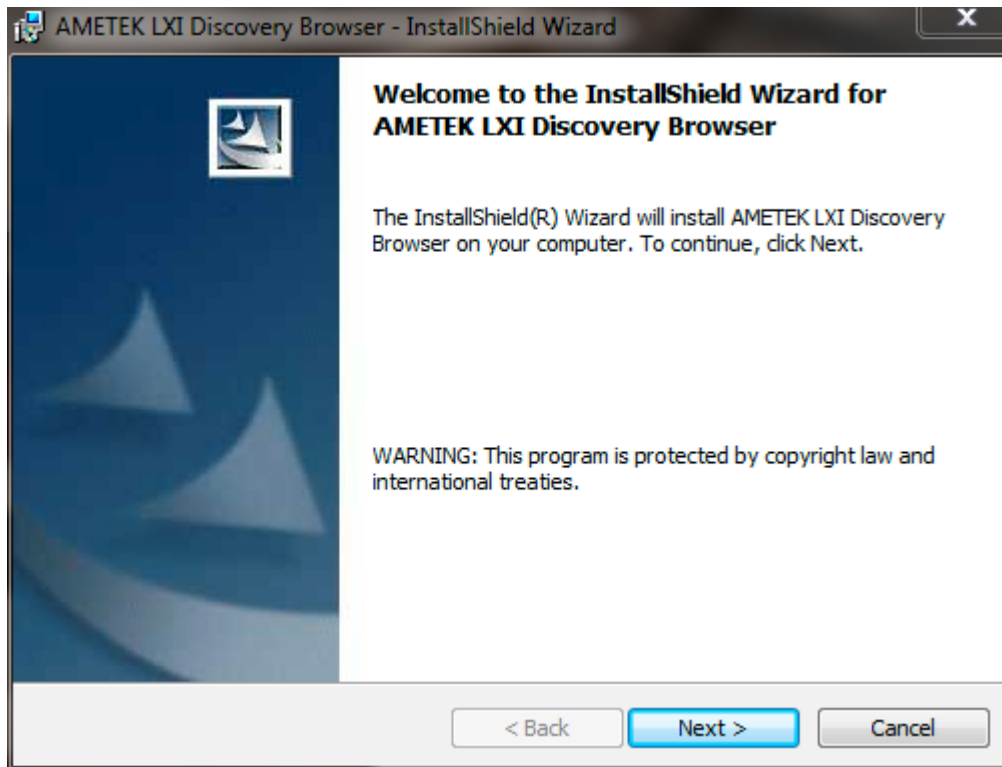
## AMETEK LXI DISCOVERY BROWSER

The AMETEK LXI Discovery Browser is a software tool provided by AMETEK. This tool can be used to automatically locate LXI compliant devices on your network. This is especially helpful if any of them are using DHCP. In this case, the IP address of the device is not known at power up since it is being automatically set by the network's DHCP server. The AMETEK LXI Discovery Browser will scan the network and return the IP addresses of any attached LXI compliant devices.

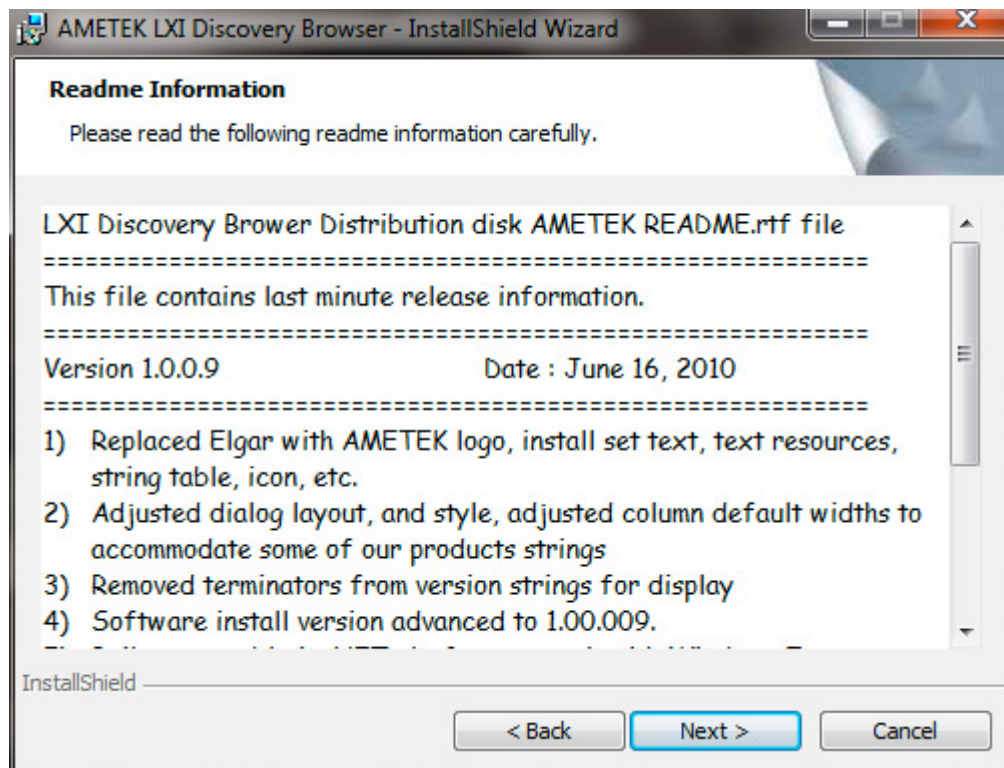
### Installing the AMETEK LXI Discovery Browser

The software for the XTR can be downloaded from the AMETEK Programmable Power website.

1. Go to the folder for **LXI Discovery Browser and ENet Test Utility**.
2. From there go to the **EVXIBrowse** directory.
3. Go to the **Disk1** directory.
4. In the **Disk1** select the **Setup** application. A window similar to the following figure should appear.

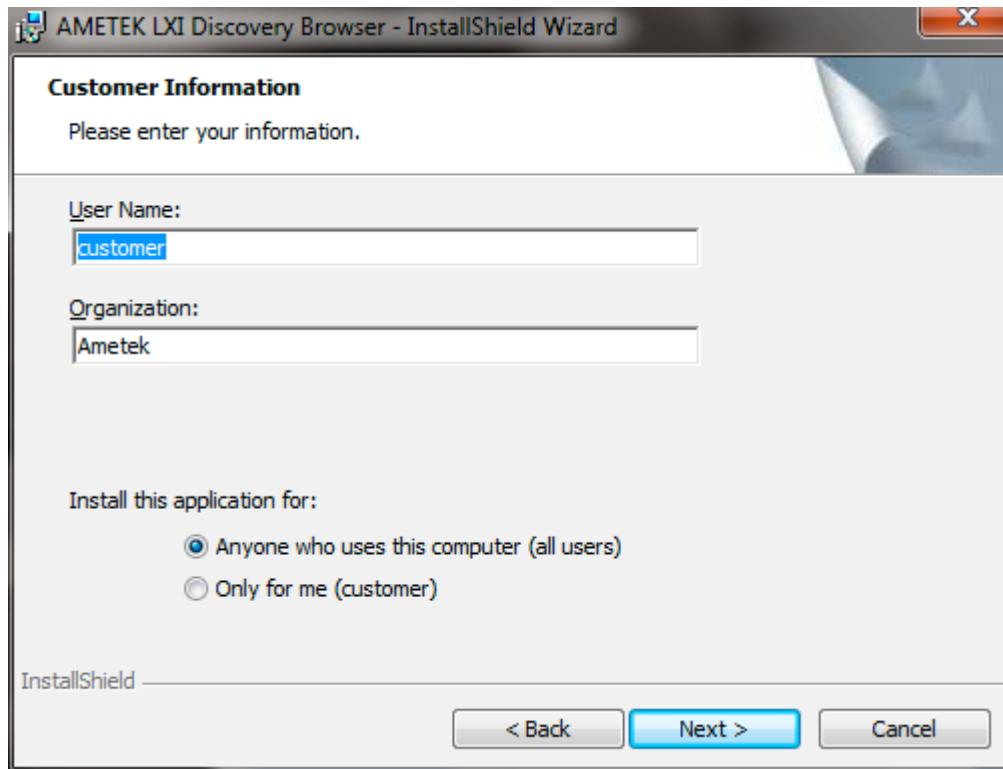


5. Click **Next** and view any last-minute release information in the README file.





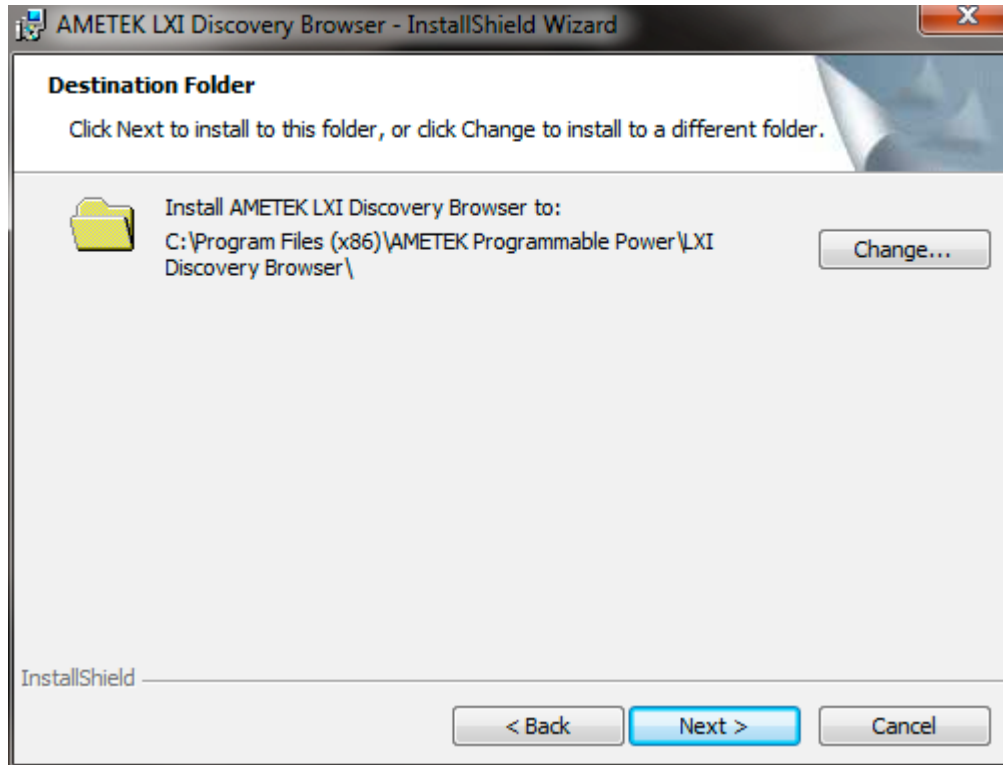
6. Click **Next**, which takes you to the Customer Information window.



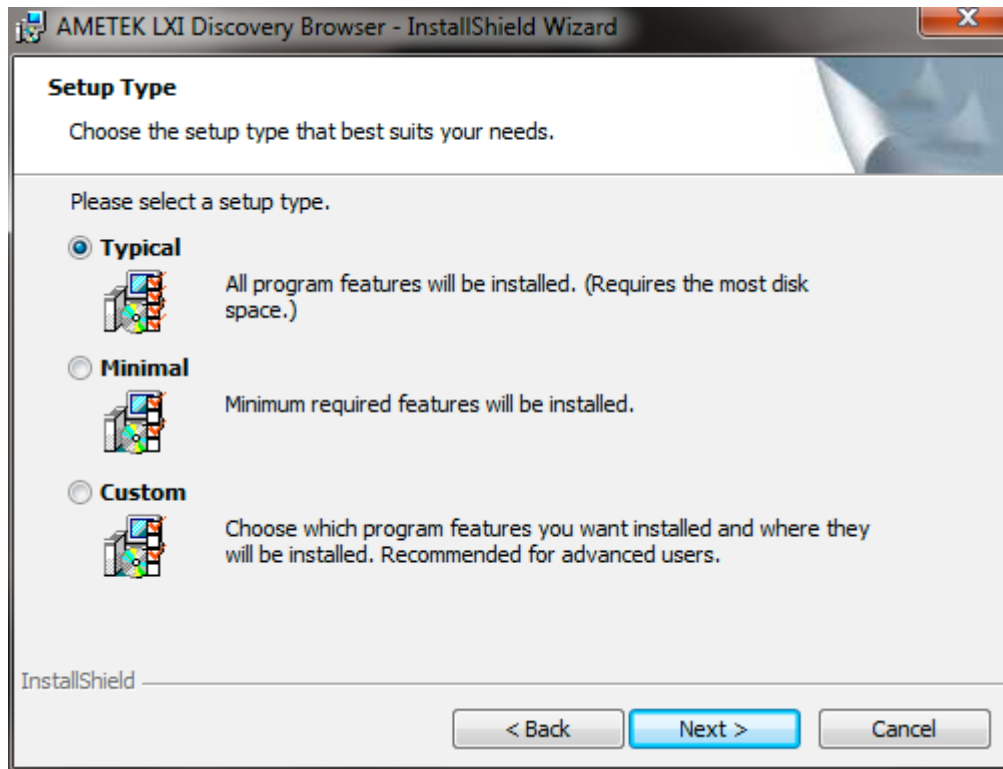
The screenshot shows a window titled "AMETEK LXI Discovery Browser - InstallShield Wizard". The window contains a "Customer Information" section with the instruction "Please enter your information." Below this are two text input fields: "User Name:" with the text "customer" and "Organization:" with the text "Ametek". Underneath these fields is the section "Install this application for:" with two radio button options: "Anyone who uses this computer (all users)" (which is selected) and "Only for me (customer)". At the bottom of the window, there are three buttons: "< Back", "Next >" (highlighted in blue), and "Cancel". The "InstallShield" logo is visible in the bottom left corner of the window.

7. Enter your user name and organization as well as your installation preference and then click **Next**.

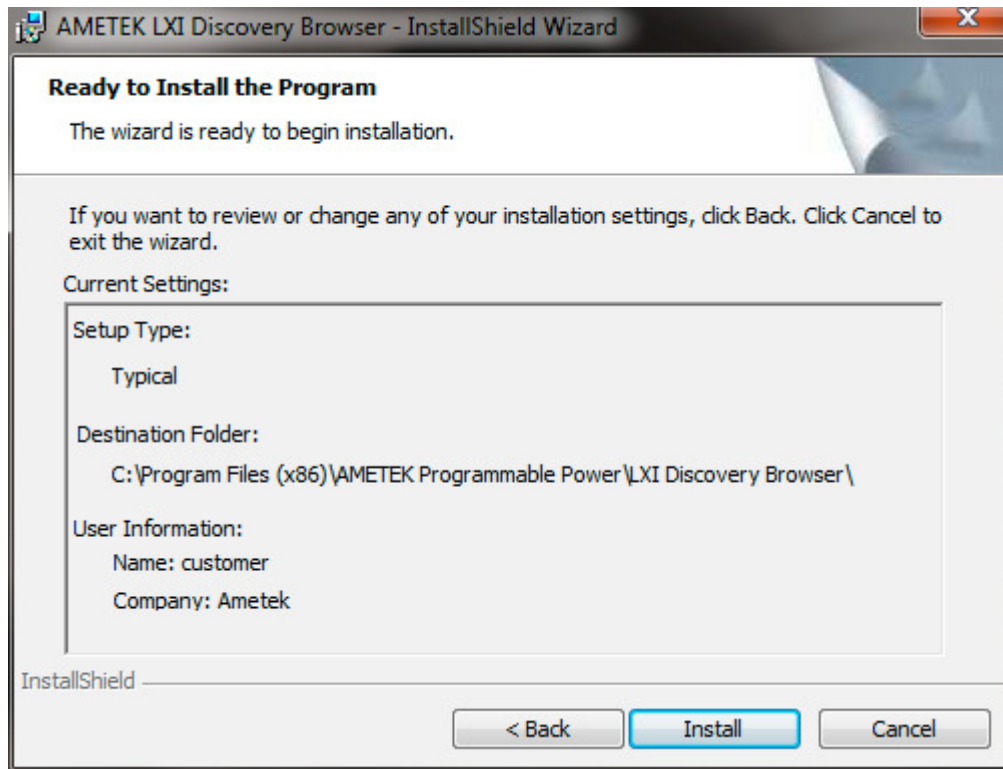
8. Either accept the automatic Destination Folder by clicking **Next** or choose another Destination Folder by clicking the **Change** button and navigating to your preferred installation directory; once selected click **Next**.



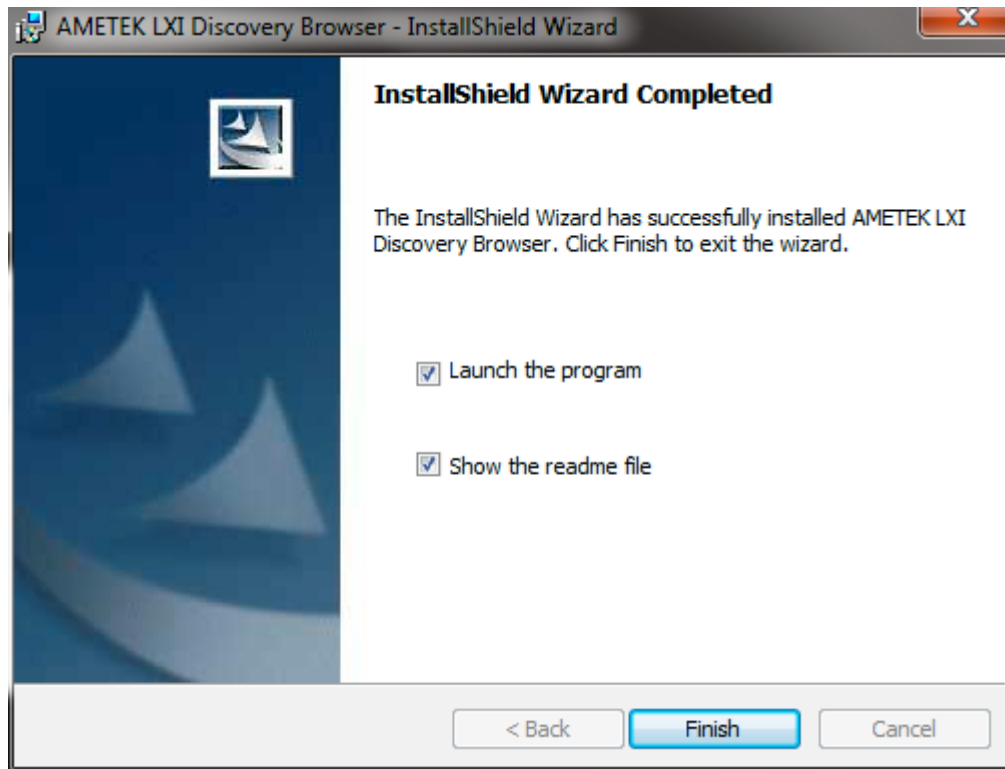
- In the Setup Type window, choose **Typical** and click **Next**



10. Check that your Settings are correct and then click **Install**

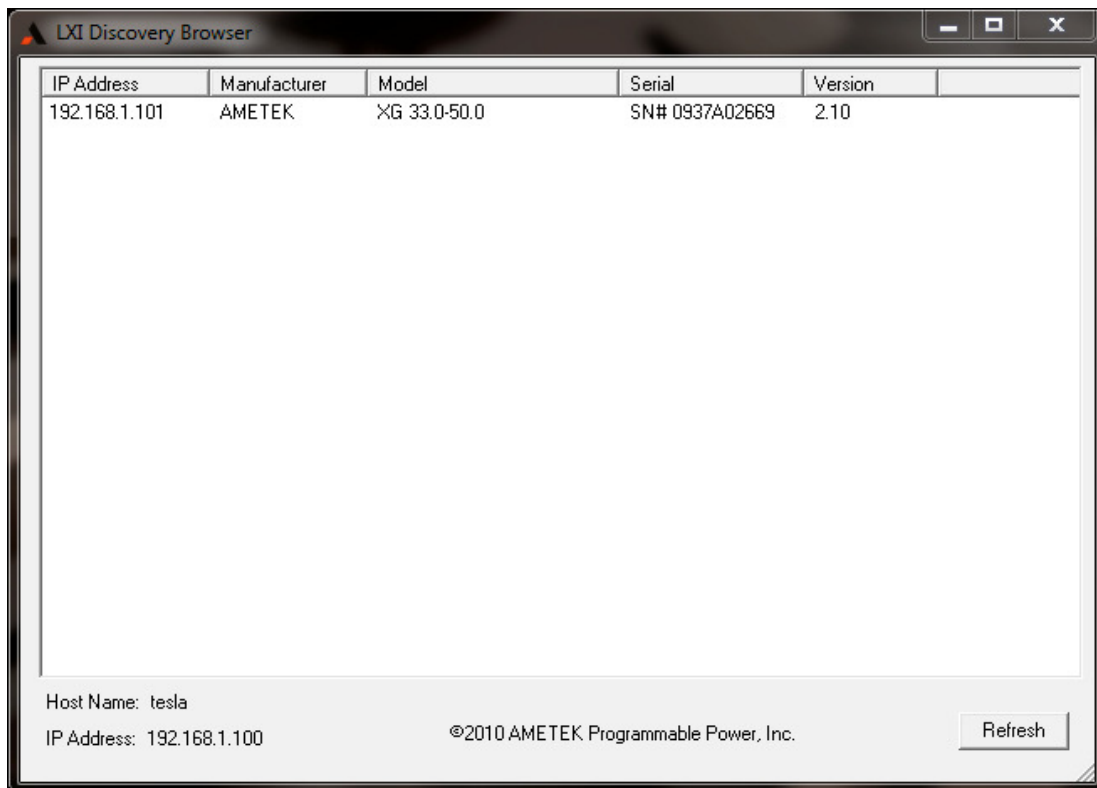


11. If the installation was successful, a window similar to the following will appear



## Using the AMETEK LXI Discovery Browser

Once installed, the AMETEK LXI Discovery Browser simply needs to be started up. The following figure shows an XG power supply being detected on the network. (If there are multiple power supplies connected, their identifying information will also appear in the LXI Discovery Browser window).



Select the specified power supply and double-click it to launch a Web browser that will open the LXI homepage of the selected power supply.

Clicking the **Refresh** button in the lower right corner of the window will cause the AMETEK LXI Discovery Browser to rescan the network for LXI compliant devices.

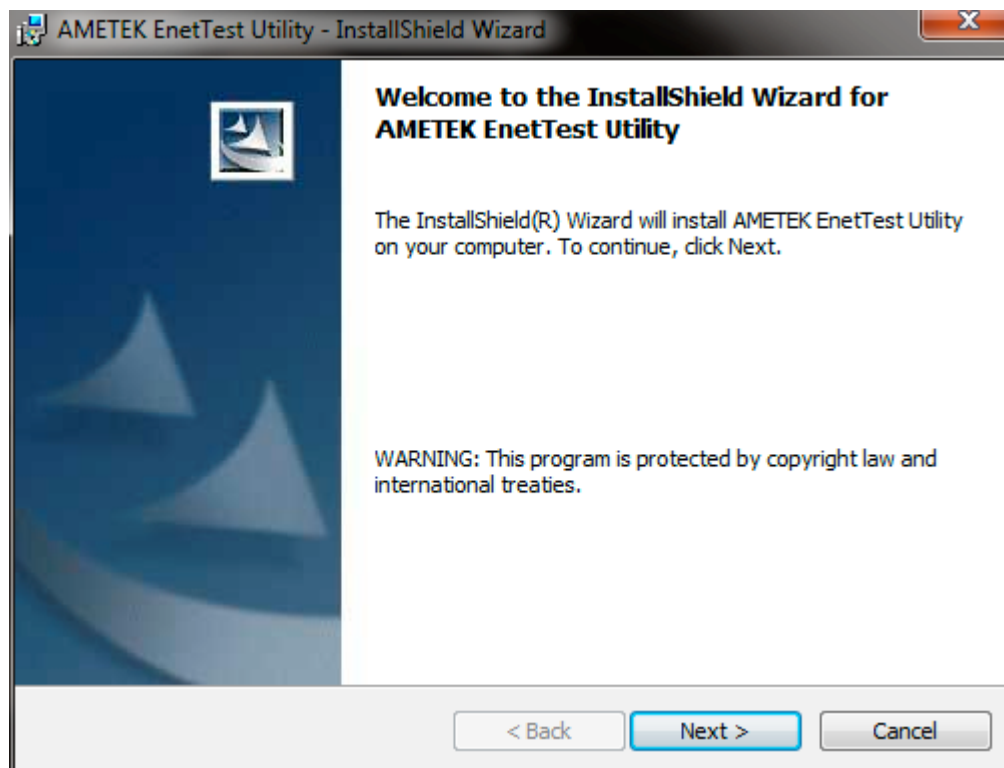
## AMETEK ENETTEST UTILITY

In addition to the AMETEK LXI Discovery Browser, AMETEK also provides another useful utility: the AMETEK EnetTest Utility. This software application provides an interface for sending SCPI commands to a device and receiving its responses over the Ethernet.

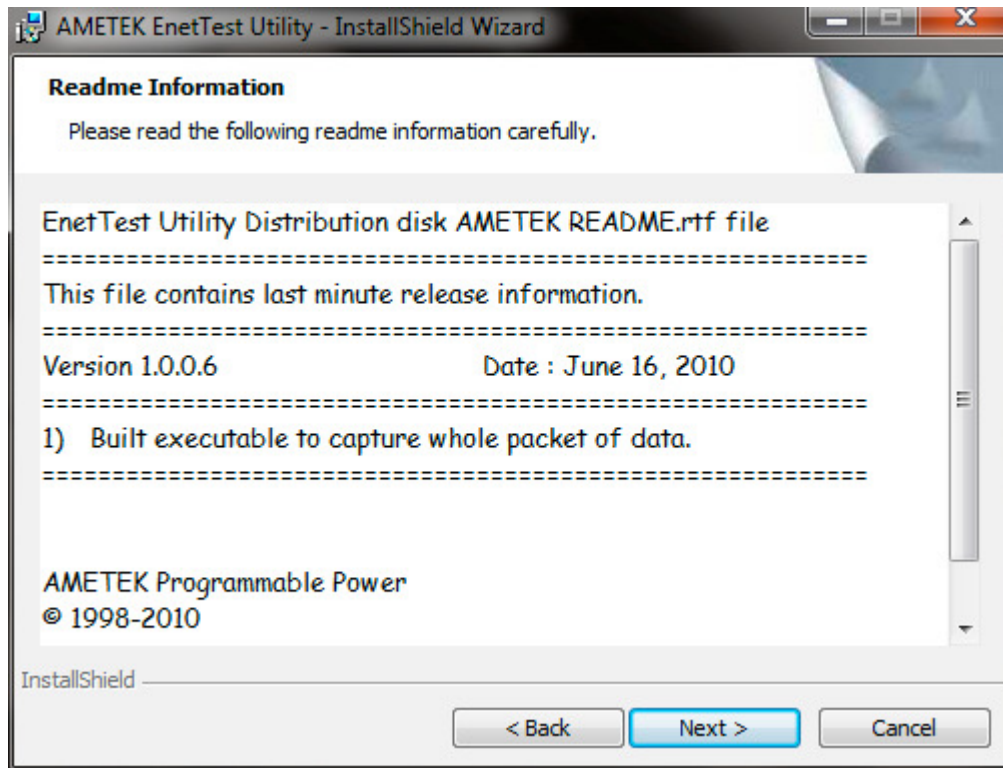
### Installing the AMETEK EnetTest Utility

The software for the XTR can be downloaded from the AMETEK Programmable Power website.

1. Go to the folder for **LXI Discovery Browser and ENet Test Utility**.
2. From there go to the **EnetTest** directory.
3. Go to the **Disk1** directory.
4. In the **Disk1** directory select the **Setup** application. A window similar to the following diagram should appear.

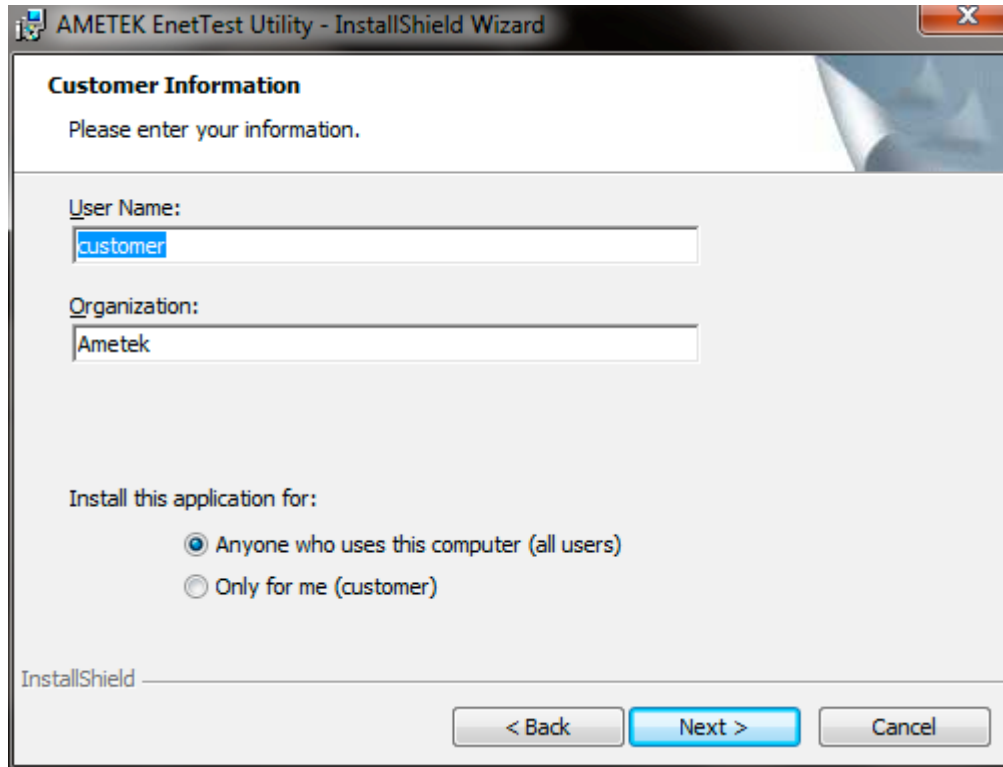


5. Click **Next** and view any last-minute release information in the README file.





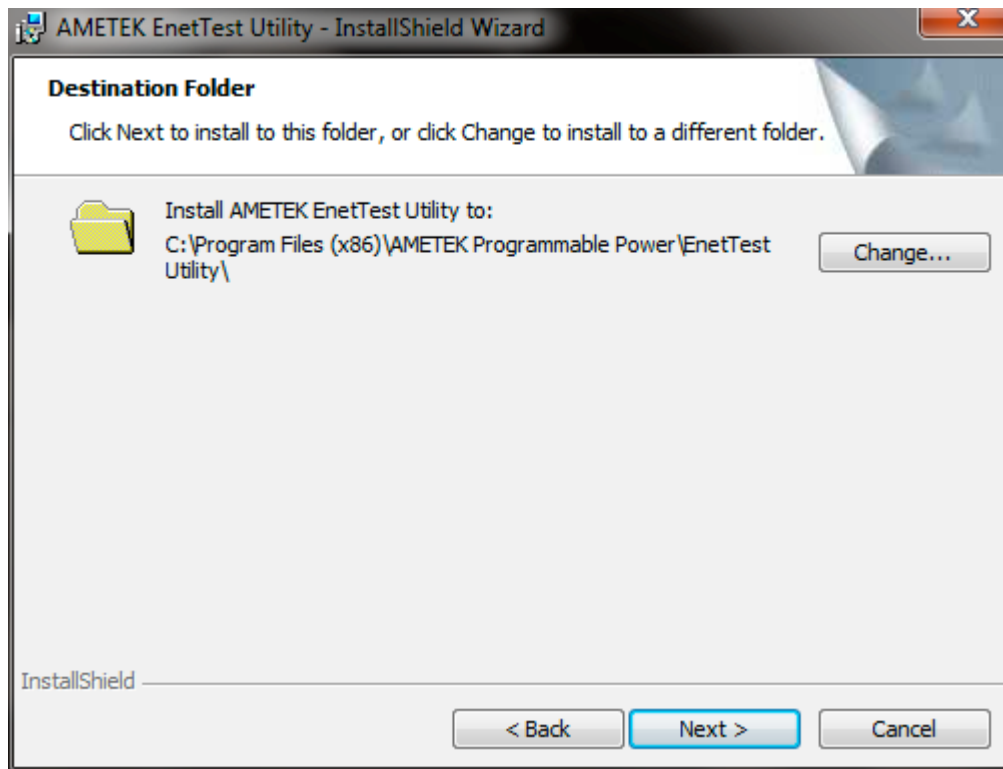
6. Click **Next**, which takes you to the Customer Information window.



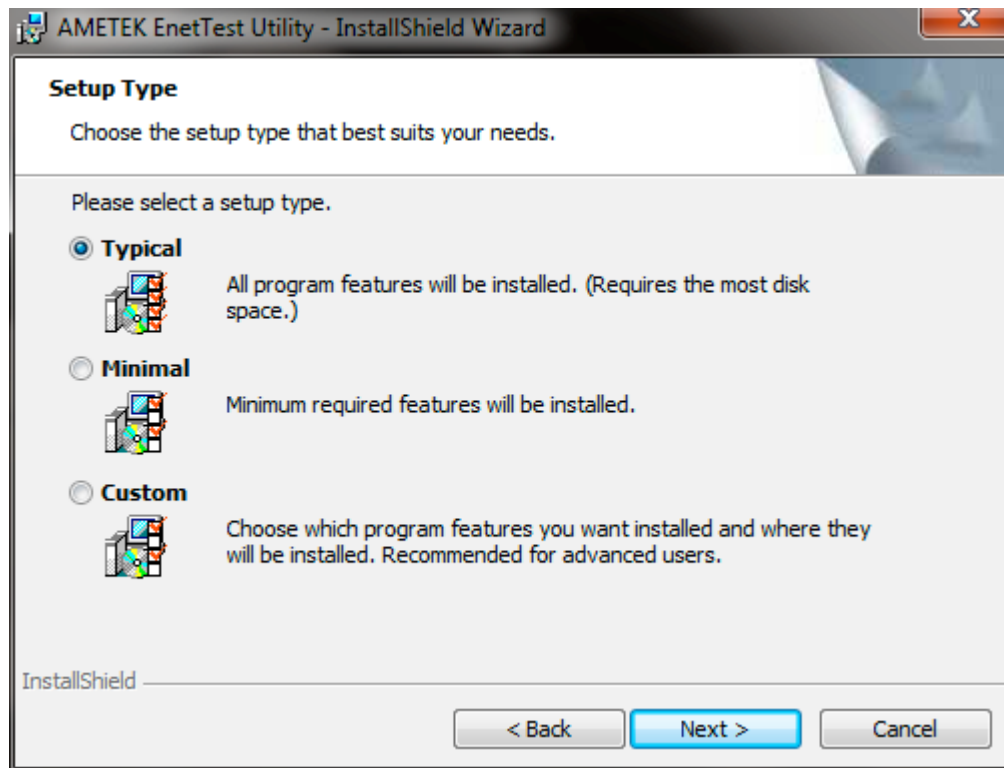
The screenshot shows a Windows-style dialog box titled "AMETEK EnetTest Utility - InstallShield Wizard". The main heading is "Customer Information" with the instruction "Please enter your information." Below this, there are two text input fields: "User Name:" containing the text "customer" and "Organization:" containing the text "Ametek". Underneath, there is a section titled "Install this application for:" with two radio button options: "Anyone who uses this computer (all users)" which is selected, and "Only for me (customer)". At the bottom left, the text "InstallShield" is visible. At the bottom right, there are three buttons: "< Back", "Next >" (highlighted in blue), and "Cancel".

7. Enter your user name and organization as well as your installation preference and then click **Next**

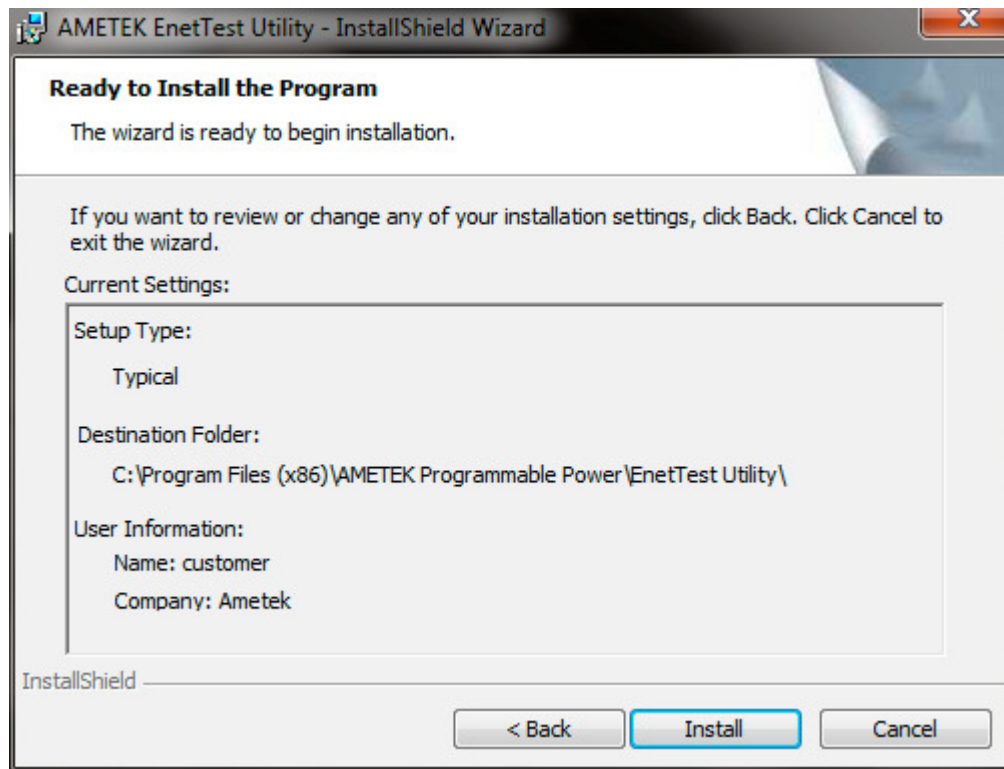
8. Either accept the automatic Destination Folder by clicking **Next** or choose another Destination Folder by clicking the **Change** button and navigating to your preferred installation directory; once selected click **Next**.



9. In the Setup Type window, choose **Typical** and click **Next**



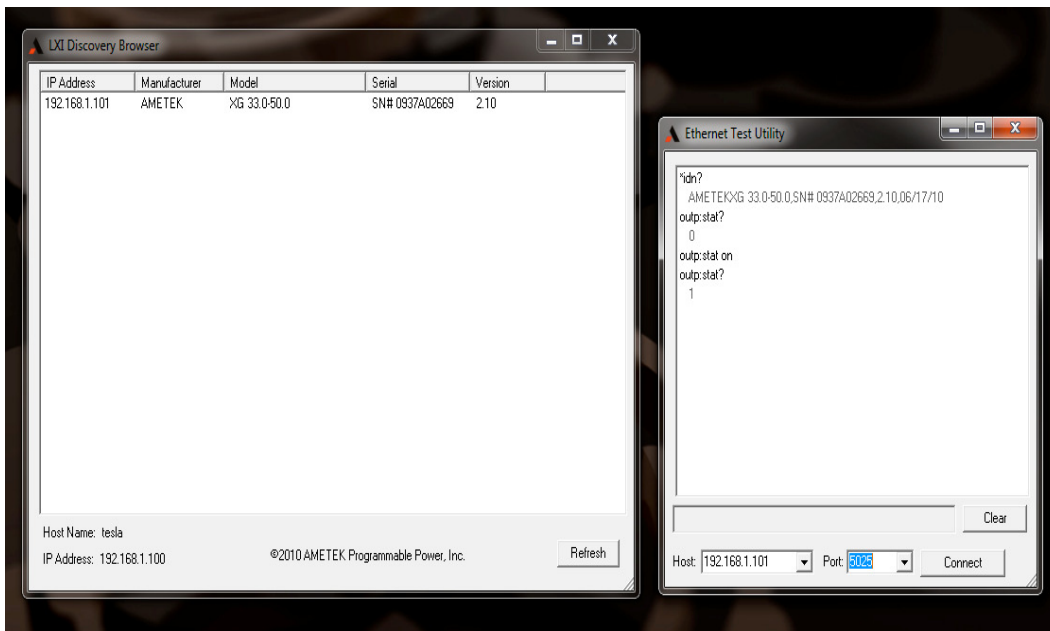
10. Check that your Settings are correct and then click **Install**



11. After a brief installation process, the utility should be available.

## Using the AMETEK Ethernet Test Utility

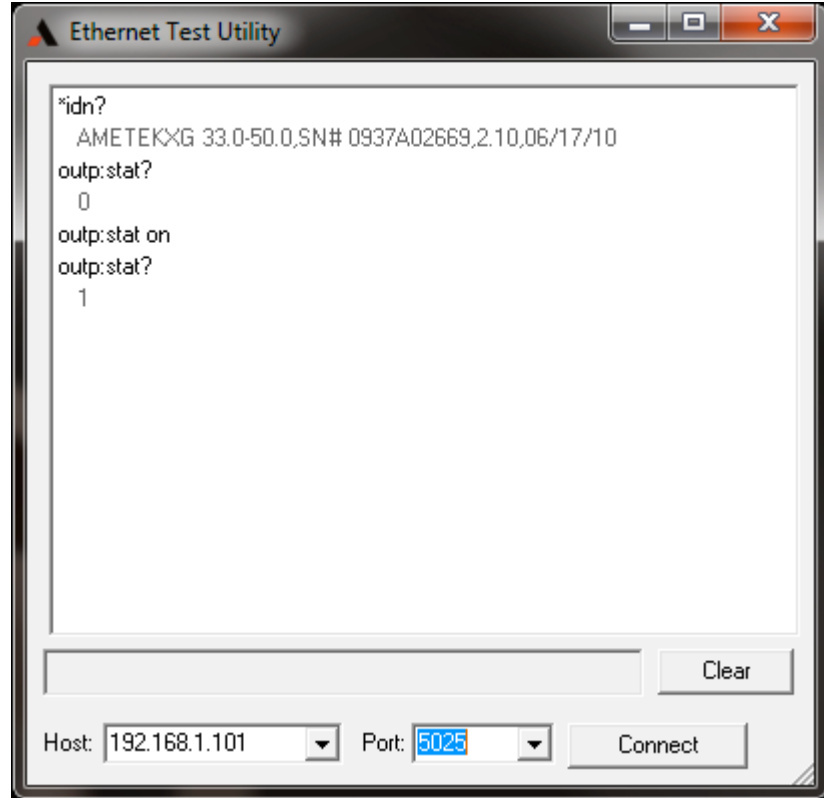
In order to use the AMETEK Ethernet Test Utility, its Host and Port fields need to be properly set. The Host field should be set to the power supply's IP Address. The Port field should be set to the power supply's port field (unless the port has been changed, it defaults to 5025.) The AMETEK LXI Discovery Browser may be useful in this step to determine the power supply's IP Address. For example, the following diagram shows the AMETEK LXI Web Browser on the left, and the parameters properly filled out on AMETEK Ethernet Test Utility on the right.



6

In this case, the AMETEK LXI Discovery Browser was used to locate the power supply and determine that its address is at 192.168.1.101. This address was entered into the **HOST** field of the EnetTest Utility.

With the **Host** and **Port** fields of the Ethernet Test Utility set, interaction with the power supply through SCPI commands can begin, as the following figure shows:



## SETTING LAN PARAMETERS

There are three ways to set the required LAN information on the power source: through the Ethernet connection, through the serial or USB port, or through the Web interface.

### Setting LAN Parameters via Ethernet

Use the "GetAssignIPAddress.exe" Windows utility program that is distributed on the CD ROM with every power source. This utility uses the network connection to set parameters on the power source; therefore, the power source and the PC will have to be connected to the same network through a hub or to each other using a crossover network cable (local network).

## Setting LAN Parameters via Serial or USB Port

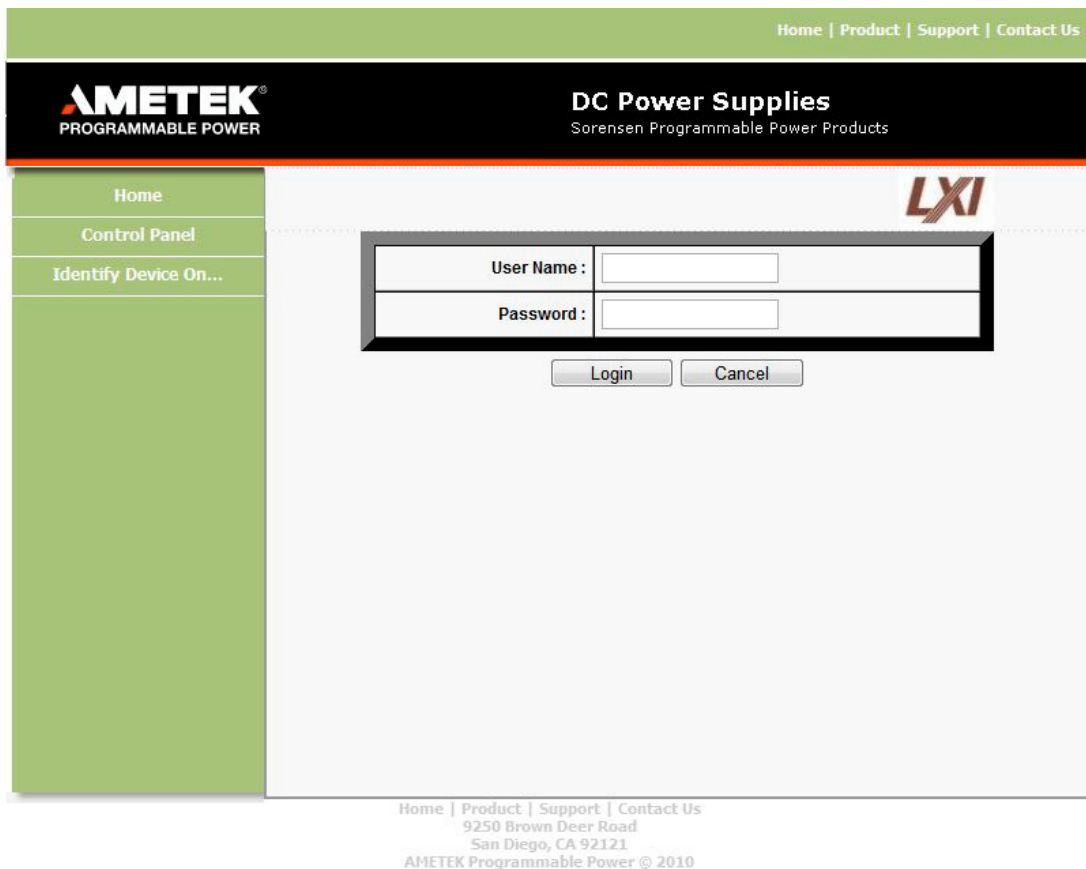
Set the parameters using SCPI commands; refer to Chapter 5 of the User’s Manual for Remote Operation.

To use the CONFIGURATION menu, press the MENU and use the up/down error keys to display the CONFIGURATION entry. Place the pointer on CONFIGURATION and press the ENTER key. Then scroll down until you see LANNetwork and press ENTER again.

The following fields are available in the LANNetwork menu:

## Setting LAN Parameters via Web Interface

Follow the instructions in the section on CONNECTING TO A NETWORK in this chapter to reach the Web page interface. Click on the Configuration tab. This should bring up the following page.



By default the user name and password are both “admin”.  
 Entering admin in both fields will bring up the IP Address  
 Configuration page (see next):

Home | Product | Support | Contact Us

**AMETEK**  
PROGRAMMABLE POWER

**DC Power Supplies**  
Sorensen Programmable Power Products

Home

Change Password

Control Panel

Identify Device On...

**LXI**

### IP Address Configuration

Obtain IP address automatically

DHCP:  Enable  Disable

AutoIP:  Enable  Disable

DHCP Host Name:

Use the following IP configuration:

IP Address:

Subnet Mask:

Default Gateway:

DNS Server:

Description:

Home | Product | Support | Contact Us  
 9250 Brown Deer Road  
 San Diego, CA 92121  
 AMETEK Programmable Power © 2010

From this page, the various LAN parameters can be set. The following table provides a list of the LAN parameters and their descriptions.



**Table 6-1 LAN Setting Screens**

LAN Parameter	Description
IP Address	<p>Use the <b>SYST:COMM:LAN:ADDRess</b> command from a terminal to change the address</p> <p>To set a fixed ip address (i.e. 192.168.1.100) enter  <b>SYST:COMM:LAN:ADDR "192.168.1.100"</b></p> <p>Note that the IP address is placed in quotes.</p> <p>To set the unit for DHCP mode enter  <b>SYST:COMM:LAN:ADDR "0.0.0.0"</b></p> <p>Note that this setting will not be made until either the power is cycled or the <b>SYST:COMM:LAN:APPY</b> command is entered.</p>
MAC Address	<p>This is the Media Access Control address. It is a 16 digit hexadecimal value. This number is unique to each device and may not be changed by the user. It is visible as a serial tag which is placed on the rear of the unit.</p> <p>The MAC address may be displayed with the query command,  <b>SYST:COMM:LAN:MACA?</b></p> <p><b>Note:</b> If the MAC Address displayed is corrupted or does not match the serial tag, there may have been a problem retrieving the LAN port settings. This can happen if a static IP was set that conflicts with another device on the network. To recover, turn on power to the unit while holding down the SET key. This will allow the unit to boot without attempting to collect the IP settings. You can then set the required IP values. [See IP Address above].</p>
GWAddress	<p>Gateway address setting. A <b>default gateway</b> is a node (a router) on a computer network that serves as an access point to another network.</p> <p>This value can be changed by using the command,  <b>SYST:COMM:LAN:GWAD &lt;address&gt;</b></p> <p>For example to set the gateway address to 192.168.1.1, use the command  <b>SYST:COMM:LAN:GWAD "192.168.1.1"</b></p> <p>Any change to this value will NOT take effect until after power to the unit has been cycled.</p>

LAN Parameter	Description								
HostBits	<p>Number of host bits as opposed to network bits in network mask. A CIDR class C network uses 24 network bits and 8 host bits. (Class A = 24, Class B = 16). This value can be changed with the command,  <b>SYST:COMM:LAN:CLASS &lt;number&gt;</b></p> <p>As an example, to set to Class A, the command would be  <b>SYST:COMM:LAN:CLASS 24</b></p> <p>Note that many systems refer to an alternate description referred to as the subnet mask. Some conversions from subnet mask to class are:</p> <table border="0" data-bbox="609 766 844 919"> <tr> <td style="text-align: center;"><u>Subnet Mask</u></td> <td style="text-align: center;"><u>Class</u></td> </tr> <tr> <td style="text-align: center;">255.255.255.0</td> <td style="text-align: center;">24</td> </tr> <tr> <td style="text-align: center;">255.255.0.0</td> <td style="text-align: center;">16</td> </tr> <tr> <td style="text-align: center;">255.0.0.0</td> <td style="text-align: center;">8</td> </tr> </table> <p>Any change to this value will NOT take effect until after power on the unit has been cycled.</p>	<u>Subnet Mask</u>	<u>Class</u>	255.255.255.0	24	255.255.0.0	16	255.0.0.0	8
<u>Subnet Mask</u>	<u>Class</u>								
255.255.255.0	24								
255.255.0.0	16								
255.0.0.0	8								
Port No	<p>TCP remote port number. This value must be set to <b>5025</b> (SCPI) to support the built in Web page.  This value can be changed with the port number command:  <b>SYST:COMM:LAN:PORT &lt;number&gt;</b></p> <p>For example to set the tcp port to 5025, the command would be  <b>SYST:COMM:LAN:PORT 5025</b></p> <p>Any change to this value will NOT take effect until after power on the unit has been cycled.</p>								
LAN Default	<p>Lan factory default settings are entered by setting the right knob to the PGM location, and then selecting LAN with the left knob and pressing and holding it until the "LAN R5t" message appears on the front panel. The IP address is set to DHCP or AUTO IP.</p> <p>Alternatively, the LAN may be reset with the SCPI command,  <b>SYST:COMM:LAN:DEFAULT</b></p>								

Once you have an IP address, you can test the IP address from your Windows PC by using the ping utility under MS DOS. To use the ping utility, bring up a DOS window using the start menu:

**Start>Programs>Accessories>Command Prompt)**

At the command prompt type:

**ping <IP address>.**

This will send an IP ping request to the power source. For this to work, the power source must be turned on and connected to the same network as the PC. Also, the power source interface configuration must be set to use a baud rate of 460,800. If the IP address is found, it will look like this:

```
Microsoft(R) Windows DOS
(C)Copyright Microsoft Corp 1990-2001.

C:\>ping 100.10.1.63

Pinging 100.10.1.63 with 32 bytes of data:

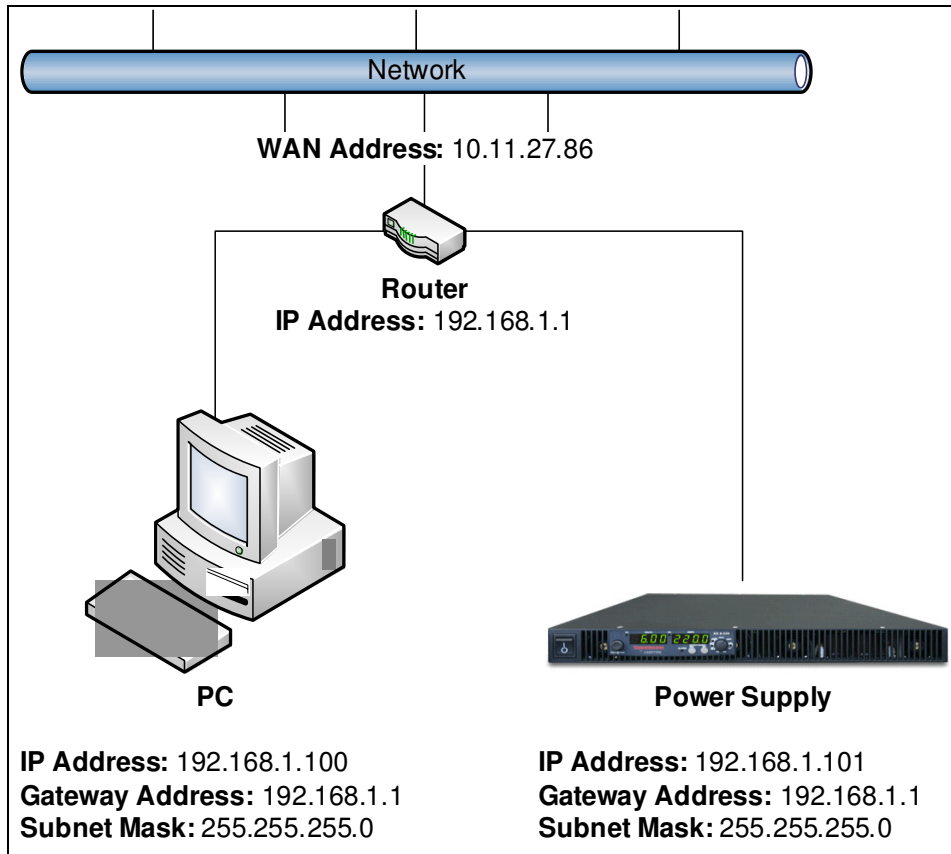
Reply from 100.10.1.63: bytes=32 time<1ms TTL=64
Reply from 100.10.1.63: bytes=32 time<1ms TTL=64
Reply from 100.10.1.63: bytes=32 time<1ms TTL=64
Reply from 100.10.1.63: bytes=32 time<1ms TTL=64

Ping statistics for 100.10.1.63:
    Packets: Sent = 4, Received = 4, Lost = 0 (0% loss),
    Approximate round trip times in milli-seconds:
    Minimum = 0ms, Maximum = 0ms, Average = 0ms
```

## CONNECTING TO A NETWORK

There are two basic situations to deal with in communicating with the power supply from a PC. They depend on whether or not the PC is on the same side of a router as the power supply.

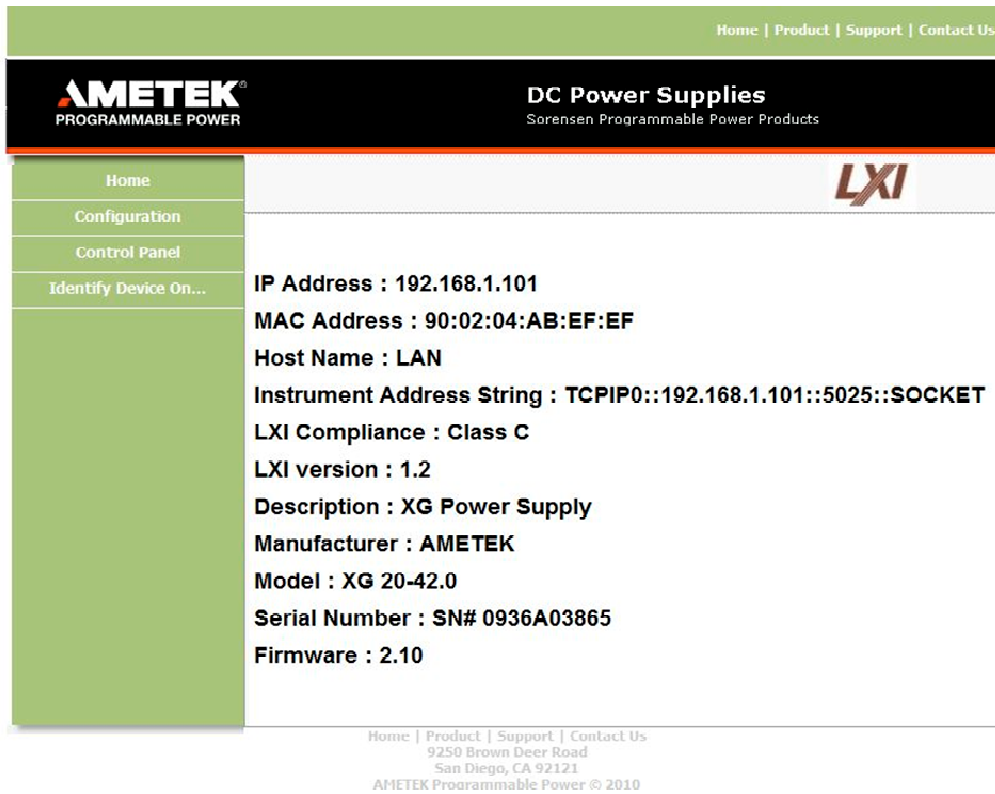
## Connecting with PC on Same Side of Router as Power Supply



**Figure 6-35 PC on Same Side of Router as Power Supply**

The simplest case is when they are both on the same side as in Figure 6-. In the example of Figure 6-, the router has assigned addresses to the power supply and to the PC using DHCP. For this case, the router has assigned an address of 192.168.1.100 to the PC and an address of 192.168.1.101. To connect to the power supply by a Web browser simply enter the power supply's address of "192.168.1.101" into the Web browser's address bar. This will open up the power supply's Home page. It should appear similar to Figure 6-.

**Please note that the Web page requires Java to be installed on the Web browser for it to display properly.** Java can be installed from the [Java website](#).



**Figure 6-36 Home Page**

An easy way to get the power supply’s address is to use the AMETEK LXI Discovery Browser. Simply turn your power supply on. You may need to click the refresh button in order to locate the supply. But if it is reachable from your PC, then it will display the power supply. You can double click on the power supply to automatically bring up a Web browser that will open to the power supply’s Home page. Figure 6-1 shows a screen capture of the LXI Discovery Browser locating a power supply.

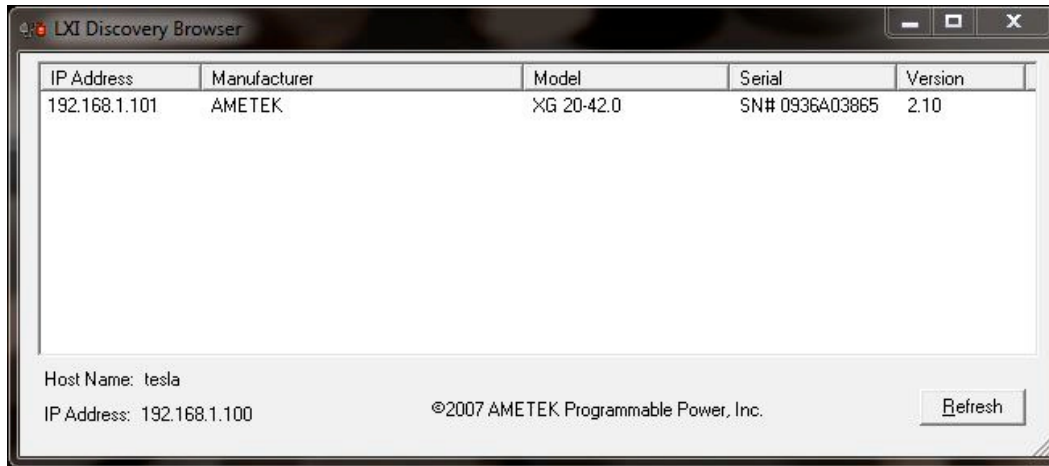


Figure 6-17 AMETEK LXI Discovery Browser

## Connecting with Power Supply Hidden Behind a Router

It is more difficult to communicate with the power supply when it is “hidden” from the PC by a router. An example of such a situation is in Figure 6-. In this case the PC cannot “see” the power supply. Instead it only sees the router at its address of 10.11.27.86 (this address is given as an example only.)

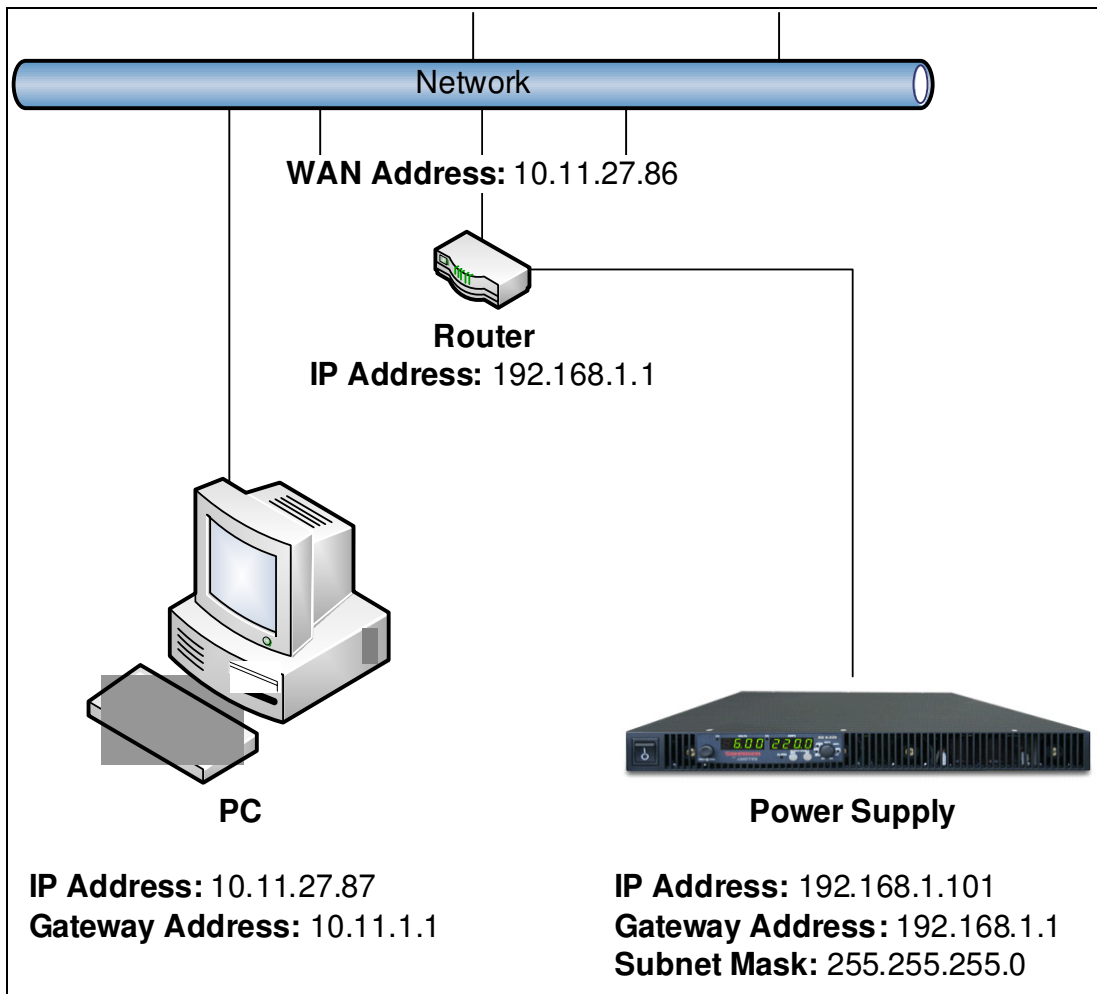


Figure 6-38 Power Supply Hidden Behind a Router

In order to send messages from the PC to the power supply, it is necessary to instruct the router to perform **port forwarding**. This will instruct the router to forward messages it sees on a certain port to another address. In this case the other address will be the power supply's address. This example will show how to perform port forwarding for a Linksys router.

**Consult your router's documentation if you have another router.**

Connect to your router's home page. If you have a PC connected on the same side of the router as the power supply, then you can usually do this by pointing your Web browser to the address of "192.168.1.1". (Most Linksys routers use this address for the router.) You should get a home page similar to the following:

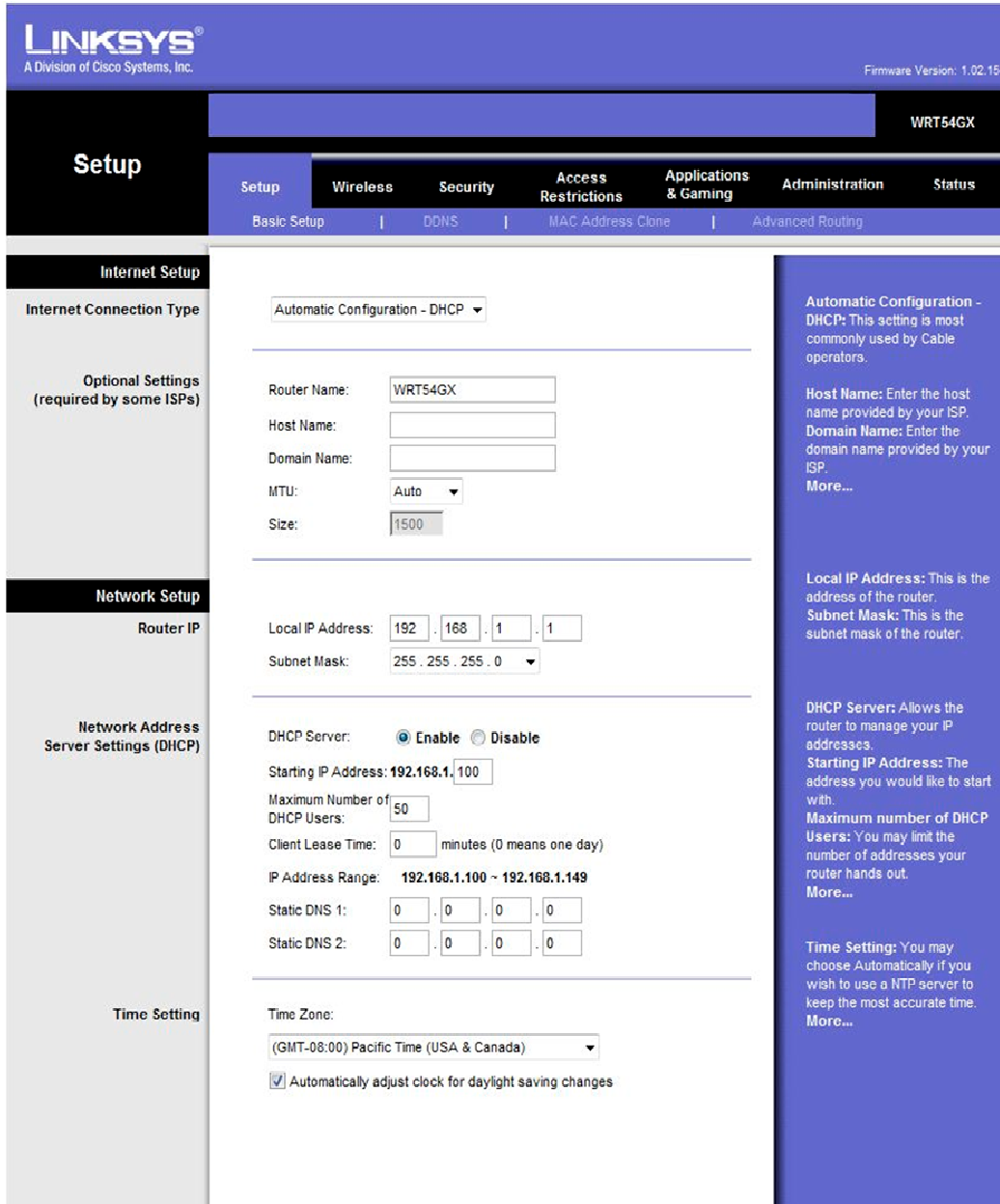
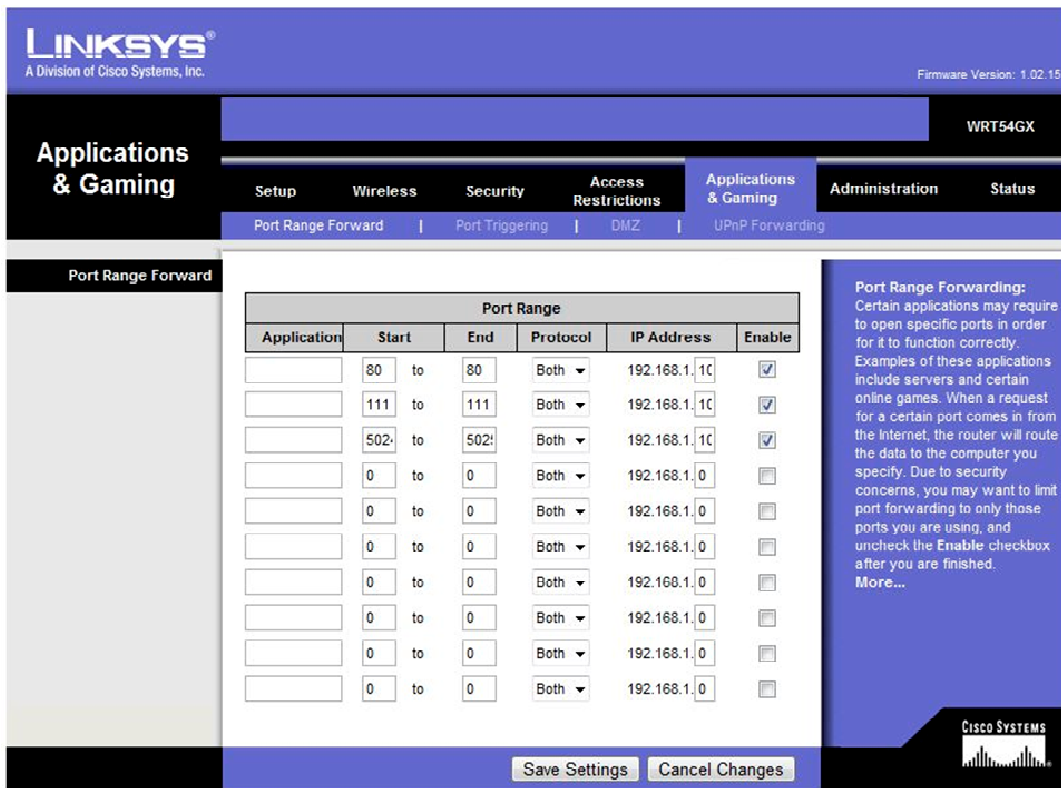


Figure 6-39 Router Home Page



Look for a tab that will take you to a location for port forwarding. In this case, it is the tab for **Application & Gaming**. Forward messages on ports 80, 111, 5024, and 5025 to the power supply's address (in this case it is 192.168.1.101) When finished, the page should look similar to Figure 6-. Click the **Save Settings** button when complete.



6

**Figure 6-40 Port Forwarding**

Looking at the **Status** tab, you should be able to find the router's address. Now you should be able to connect to the power supply from the original PC (the one not behind the router) using the router's address.

## Socket Port Number

Now that a connection has been verified, you can develop your application code. If you are using one of the Microsoft environments, the Winsock protocol, which is part of the Windows operating system, can be used. Similar capabilities are supported on other operating systems.

To use Winsock, you will have to specify the port number of the power source's LAN interface. The port number determines the

protocol for the communication. The XG/XTR power source uses ASCII characters and instrument SCPI commands for remote control. The IANA registered Port number for the Instrument SCPI interface is 5025.

TCP Remote port = 5025

The socket number can be changed on the power source using the `SYST:COMM:LAN:PORT` command. Refer to the SYSTEM COMMANDS section that follows.

## Instrument Drivers and Application Software

Instrument drivers for National Instruments LabWindows/CVI and LabView are generally available for download from the AMETEK Programmable Power Web site at [www.programmablepower.com](http://www.programmablepower.com). Also available are ready-to-use interactive graphical user interface (GUI) programs for download.

# SYSTEM COMMANDS

The system commands control the system-level functions of the power source.

## Subsystem Syntax

SYSTem		
:COMMunicate		
:LAN		
:ADDRess		Set LAN IP address
:APPLY		Apply the change in setting
:CLASSs		Set LAN Host bits
:DEFault		Set LAN to a default known
	setting	
:DESCRiption		Set user description
:DNSAddress		Set LAN DNS address
:GWAddress		Set LAN Gateway
:PASSword		Set LAN password
:PORT		Set LAN socket port address
:MACAddress		Read the MAC address

### SYSTem:COMMunicate:LAN:ADDRess

This command will set the LAN IP address. The query format returns the IP address set. To query the actual IP address used by the LAN interface (in case the IP address is not static but assigned by a DHCP server), the NCON parameter (Network Connection Setting) must be added to the query. The default value is 0.0.0.0.

Command Syntax	SYSTem:COMMunicate:LAN:ADDRess <NRF>
Parameters	ddd.ddd.ddd.ddd <IP address>
Example	SYST:COMM:LAN:ADDR 255.255.167.2
Query Syntax	SYST:COMM:LAN:ADDR? SYST:COMM:LAN:ADDR? NCON
Returned Parameters	<CRD>

### SYSTem:COMMunicate:LAN:APPLY

This command will apply the changes in LAN setting. The controller will go to reset condition and the new LAN setting will take effect.

Command Syntax	SYSTem:COMMunicate:LAN:APPLY
Parameters	none
Example	SYST:COMM:LAN:APPL
Query Syntax	no query for this command
Returned Parameters	none



**SYSTem:COMMunicate:LAN:CLASs**

This command will set the number of host address bits or a class. The query format returns the number of bits set. To query the actual number of bits used by the LAN interface (in case the IP address is not static but assigned by a DHCP server), the NCON parameter (Network Connection Setting) must be added to the query. The default value is 8. In general Class A network is 24 bits, Class B is 16 bits and Class A is 8 bits.

Command Syntax	SYSTem:COMMunicate:LAN:CLASs <NRF>
Parameters	8 to 32
Example	SYST:COMM:LAN:CLAS 8
Query Syntax	SYST:COMM:LAN: CLAS? SYST:COMM:LAN: CLAS? NCON
Returned Parameters	<NR1>

**SYSTem:COMMunicate:LAN:DEFault**

This command will apply the changes in LAN setting to the default setting. The controller will go to reset condition and the default LAN setting will take effect. Both IP address and Gate way address are set to zero. The Host name is cleared. The password is reset to “admin”The unit is set to DHCP or Auto IP.

Command Syntax	SYSTem:COMMunicate:LAN:DEFault
Parameters	none
Example	SYST:COMM:LAN:DEF
Query Syntax	no query for this command
Returned Parameters	none

**SYSTem:COMMunicate:LAN:DESCRiption**

This command will set the user description. The description is limited to 24 characters

Command Syntax	SYSTem:COMMunicate:LAN:DESCRiption <SRD>
Parameters	<SRD>
Example	SYST:COMM:LAN:DESC “EVAL UNIT”
Query Syntax	SYST:COMM:LAN:DESC?
Returned Parameters	<SRD>

**SYSTem:COMMunicate:LAN:GWADdress**

This command will set the LAN Gateway address. The query format returns the Gateway address set. To query the actual gateway address used by the LAN interface (in case the IP address is not static but assigned by a DHCP server), the NCON parameter (Network Connection Setting) must be added to the query. The default value is 0.0.0.0.

Command Syntax	SYSTem:COMMunicate:LAN:GWADdress <NRF>
Parameters	ddd.ddd.ddd.ddd <Gateway address>
Example	SYST:COMM:LAN:GWAD 255.255.255.0
Query Syntax	SYST:COMM:LAN:GWAD? SYST:COMM:LAN:GWAD? NCON
Returned Parameters	<CRD>

**SYSTem:COMMunicate:LAN:HOST**

This command will set the Host name. The name is limited to 16 characters

Command Syntax	SYSTem:COMMunicate:LAN:HOST <SRD>
Parameters	<SRD>
Example	SYST:COMM:LAN:HOST "ACS"
Query Syntax	SYST:COMM:LAN:HOST?
Returned Parameters	<SRD>

**SYSTem:COMMunicate:LAN:PASSword**

This command will set the user password. The password is used to access to LAN configuration screen from the Web page. The default password is "admin". The description is limited to 8 characters.

Command Syntax	SYSTem:COMMunicate:LAN:PASSword <SRD>
Parameters	<SRD>
Example	SYST:COMM:LAN:PASS "admin"
Query Syntax	SYST:COMM:LAN:PASS?
Returned Parameters	<SRD>

**SYSTem:COMMunicate:LAN:PORT**

This command will set the socket port number. The query format returns the port number set. The default value is 5025.

Command Syntax	SYSTem:COMMunicate:LAN:PORT<NRF>
Parameters	0- 65535
Example	SYST:COMM:LAN:PORT 5025
Query Syntax	SYST:COMM:LAN: PORT?
Returned Parameters	<NR1>

**SYSTem:COMMunicate:LAN:MACAddress**

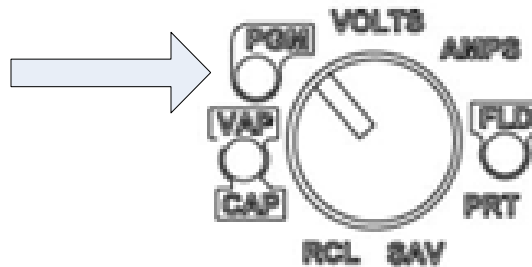
This command allows for reading out the MAC address. This command can only be used to query the MAC address. The MAC address is set at the factory and may not be changed.

Command Syntax	SYSTem:COMMunicate:LAN:MACAddress
Parameters	None
Example	SYST:COMM:LAN:MACA?
Query Syntax	SYST:COMM:LAN:MACA?
Returned Parameters	<SRD>

## LXI COMPLIANCE

The XG is compliant with LXI version 1.2, Class C. For more information on the LXI standard please visit the LXI Consortium Home Page. This section describes how certain features of LXI have been implemented in the XG power supply.

### LAN Indicator LED

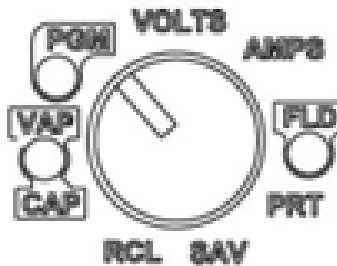


The PGM LED on the front panel is used as the LAN indicator. If there is no connection, the LED is off. If there is a connection, the LED is on. While the unit is attempting to make a connection the LED blinks. This same LED also blinks when clicking Identify Device On... on the Web interface to identify which power supply the user is communicating with.

### LAN Reset

In order to return to the factory default settings, a LAN reset may be performed. To do this

1. Set the 9 position mode control to PGM



2. Turn the rotary encoder knob (left side of front panel display) to LAN.
3. Press and Hold the rotary encoder knob until the LAN reset message appears on the front panel 7 segment display

## Introduction to the LXI Standard

This section is meant only as a brief summary of some of the features of LXI. For a more complete description of LXI please refer to the [LXI Consortium Home Page](#). The authoritative description of LXI is the [LXI standard](#).

## VXI Discovery

LXI devices are required to conform to the [VXI 11](#) discovery protocol. The AMETEK LXI Discovery Browser uses this discovery protocol to locate LXI compliant devices on the network. This makes communicating with devices and locating their addresses simpler.

## LAN Requirements

LXI mandates many useful LAN requirements

Dynamically Configured Link Local Addressing	If there is no DHCP server available, the unit will use the Dynamically Configured Link Local Addressing protocol to assign itself a link local address. This is useful for cases when a network is down or unavailable but the user still wants to connect to the power supply.
DHCP	The unit can obtain a dynamic address using the DHCP protocol
Static IP	The unit can be given a static IP

## Web Page

Must be <a href="#">W3C</a> compliant	This ensures that the pages will display correctly on all W3C compliant Web browsers
Must have a homepage which displays manufacturer, serial number, IP address, etc	This ensures all LXI compliant devices have a similar look and feel to their Web pages
Device Identification Function	A Web page button that causes an LED to flash on the power supply. This makes determining which power supply a user is communicating with simpler.
LAN configuration page	This page allows for changing the values of LAN parameters like IP address, Gateway, Subnet Mask, etc

## **Remote Procedure Calls (RPC)**

RPCs are a part of the Open Network Consortium. RPC is designed to facilitate distributed programming. In the case of power supplies it allows for a program running on a computer to communicate to any number of power supplies over the network.

## **Drivers**

LXI compliant devices are required to provide an IVI Specific Driver.



# 7

## **Calibration and Troubleshooting**

Chapter 7, Calibration and Troubleshooting, contains information and procedures for calibrating and troubleshooting the power supply.

## Introduction

The calibration of the power supply is software dependent, and there are no potentiometers to adjust.

Calibration is performed via SCPI commands. The following items need to be calibrated:

- Programmed voltage
- Voltage readback
- Programmed current
- Current readback
- Non-isolated voltage monitoring
- Isolated voltage monitoring
- Non-isolated current monitoring
- Isolated current monitoring
- Isolated source for analog programming
- Non-isolated source for analog programming
- Over voltage protection system



### **CAUTION: Equipment damage**

Calibration procedures should only be performed by qualified user.

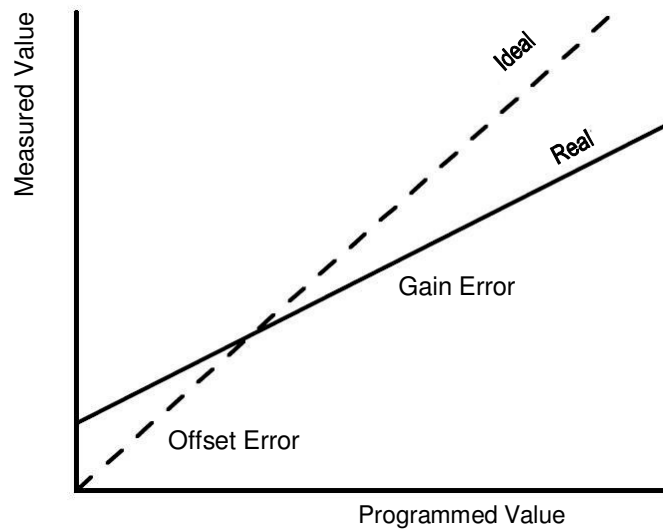
---

## Main Voltage and Current Calibration Principle

### Understanding the Problem

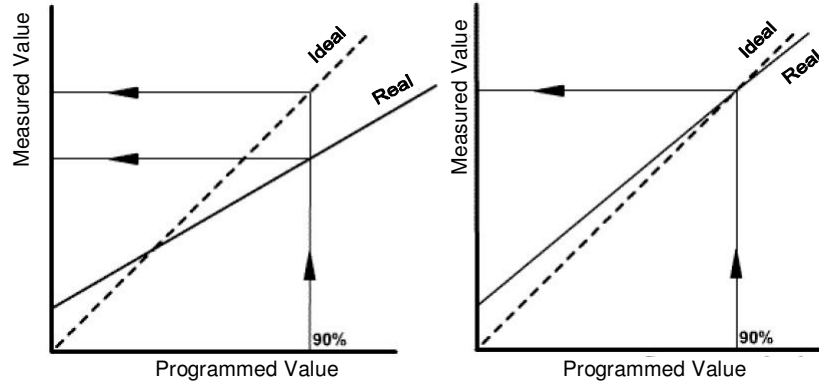
Figure 7-1 illustrates two sources of analog programming error: gain error and offset error. Gain error is the departure from the ideal slope of the measured versus programmed line. Offset error is the magnitude of the measured value when the programmed value is zero. Calibrating one will affect the other so an iterative calibration procedure is used.

For best results, iterative calibration of gain and offset will be required. After first calibration of both, repeat gain calibration for 90% of maximum value and offset calibration for 10% of maximum value. Repeat as necessary..



**Figure 7-1** Offset (Intercept) Error and Gain (Slope) Error

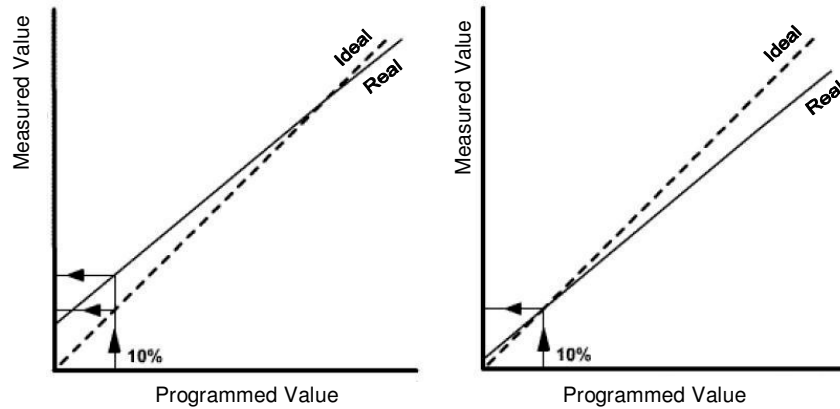
## Step 1: Gain Calibration



**Figure 7-2** Calibration: Step 1 Gain Calibration

Adjust the gain so that the real line and ideal line intersect at a programmed value of 90%.

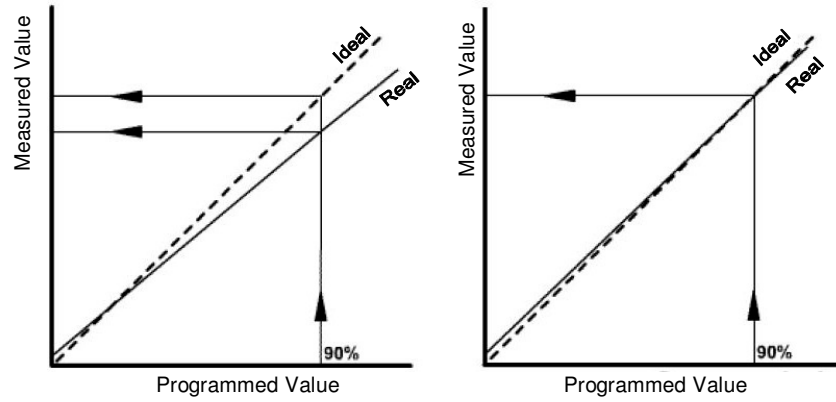
## Step 2: Offset Calibration



**Figure 7-3** Calibration: Step 2 Offset Calibration

Adjust the offset so that the real and ideal lines intersect at a programmed value of 10%.

### Step 3: Recalibrate Gain



**Figure 7-4** Calibration: Step 3 Recalibrate Gain

Repeat Step 1 for best results.

## Calibrating the Output Voltage

Gain calibration of the power supply has the greatest effect on the accuracy in the high voltage range. Offset calibration has the greatest affect on accuracy of the power supply at low voltages. The same calibration command is used for the gain and offset calibrations. The type of calibration is determined internally by the instrument depending on if the set point is above 10% of the maximum output voltage value or not. If it is above 10% of the maximum voltage, the calibration is a gain calibration; if is below 10%, it is an offset calibration.

### Gain Calibration

**To perform gain calibration:**

1. Disconnect the power supply from the load.
2. Connect the output terminals to a precision voltmeter.
3. Turn both the power supply and the voltmeter to On.
4. Set the current set point to maximum. Set the supply output to 90% of the nominal voltage level.
5. Turn on the output power.
6. Read the voltage value on voltmeter display.
7. Type the SCPI command with voltage value as parameter "data".

For example, type :CAL:OUTP 138.3 if you had an XG (or XTR) 150-5.6 calibrating with the voltage set point set to 135 V and the voltmeter was reading 138.3 volts.

### Offset Calibration

**To perform offset calibration:**

1. After performing gain calibration, set the programmed voltage 10% from nominal.
2. Read the voltage value on the voltmeter display.
3. Type the SCPI command with voltage value as parameter "data".

For example, you would type : CAL: OUT P1 2 . 3 if you had an XG (or XTR) 150-5.6 calibration with the voltage set point set to 10V and the voltmeter was reading 12.3 volts.

---

After performing offset calibration, it is recommended that you repeat gain calibration.

---

**Important:** For best results, both calibrations may be repeated several times.

---

**The SCPI Command (s) for these instructions are:**

```
[:]CALibration[<channel>]:OUTPut{:VOLTage}{<voltmeter  
reading in volts>}
```

## Calibrating the Output Current

### Gain Calibration

**To perform gain calibration:**

1. Disconnect the power supply from the load.
2. Connect the output terminals to a load representing a short circuit using a precision ammeter.
3. Turn both the power supply and the load On.
4. Set the voltage set point to maximum. Set the supply output to 90% of the nominal current level.
5. Turn on the output power.
6. The power supply starts up in Constant Current mode.
7. Read the current value on the ammeter display.
8. Type SCPI command with current value as parameter "data".

For example, type : CAL: OUTP 5.07 if you had an XG (or XTR) 150-5.6 calibrating with the current set point set to 5.04 A and the ammeter was reading 5.07 amps.

## Offset Calibration

Offset calibration of the power supply provides the best accuracy in low-range current.

### To perform offset calibration:

1. After performing gain calibration, set the current to 10% from the nominal.
2. Read the current value on the ammeter display.
3. Type SCPI command with the current value as parameter “data”.

For example, you would type : CAL : OUT P: CURR 0.50 if you had an XG (or XTR) 150-5.6 calibrating with the current set point set to 0.56 A and the actual current measured was 0.50A.

After performing offset calibration, it is highly recommended that you repeat gain calibration.

---

**Important:** For best results, both calibrations may be repeated several times. To maintain the high current accuracy of the XG/XTR family of power supplies, user current calibration should only be done with a high accuracy calibrated shunt resistor of at least 0.025% tolerance.

---

### SCPI Command

```
[:]CALibration[<channel>]:OUTPut:CURRent{<ammeter reading in amps>}
```



---

## Over Voltage Protection Calibration

---

**Important:** The Voltage Calibration must be done before performing this procedure. If this is not done the OVP calibration will be inaccurate.

---

**To calibrate the over voltage protection:**

1. Turn on the power supply.
2. Select the VAP mode to be Off.
3. Set the voltage set point to be 90% of the model voltage and the current to be 10% of the model current.
4. Turn on the main power output.
5. Execute the OVP calibration SCPI command:  
:CAL:PROT
6. The power supply will enter into self-calibration mode. The output voltage display blinks OVP CAL. After several seconds, the calibration will complete and the display will return to normal operation with output off.

Calibration of the power supply is complete.

---

**Important:** The output (main) voltage must be precalibrated.

---

**The SCPI command (s) for these instructions are:**

[:]CALibration[:VOLTage]:PROTection

## Non-isolated Analog Programming Calibration

Prior to this, the main output must be calibrated first.

---

**Important:** In calibration commands, when + or - keys are expected, any other key will exit from the calibration mode.

---

## Non-isolated Voltage Monitoring Calibration

---

**Important:** For maximum accuracy at a specific APG level, follow the calibration procedure again but use the intended operating voltage level in steps 3 and 8.

---

### To calibrate the non-isolated voltage monitoring:

1. Disconnect the load and connect the voltmeter to the output.
2. Connect the voltmeter to the non-isolated voltage monitoring output lines (J1.13 - J1.7).
3. Set the Voltage APG level to 4 V. Send the SCPI command:  
`SYST:COMM:APR:LEV 4`
4. Set the input source as Local. Send the SCPI command:  
`SYST:REM:SOUR LOC`
5. Set the main output voltage to 100% by sending the command:  
`SOUR:VOLT <ModelVolt>`  
or use the rotary adjust/Enter control.
6. Turn the main output On by pressing the OUTPUT ENABLE Main button on the front panel or send the command:  
`:OUTP ON`  
The OUTPUT ENABLE Main button will illuminate.
7. Enter interactive calibration mode by sending the SCPI command:  
`CAL:MON`
8. Press on the terminal keys - or + to reduce or increase monitoring value. Adjust the monitoring value displayed on the voltmeter that was set up in Step 1 to read as close as possible to 4.000 V.
9. Press any key other than the + or - keys to exit from interactive calibration mode.

## Non-isolated Current Monitoring Calibration

**Important:** For maximum accuracy at a specific APG level, follow the calibration procedure again but use the intended operating voltage level in steps 3 and 9.

### To calibrate the non-isolated current monitoring:

1. Short the main output with a shunt. Connect a multimeter to measure the voltage across the shunt.
2. Connect the voltmeter to the non-isolated current monitoring output lines (J1.12 - J1.7).
3. Set the Current APG level to 4 V. Send the SCPI command:  
`SYST:COMM:APR:LEV:CURR 4`
4. Set the input source as Local.
5. The SCPI command is:  
`SYST:REM:SOUR:CURR LOC`
6. Set the main output voltage to 100% by sending the command `SOUR:VOLT <ModelVolt>` or use the rotary adjust/Enter control.
7. Turn the main output On by pressing the OUTPUT ENABLE Main button on the front panel or send the command:  
`:OUTP ON`  
 The OUTPUT ENABLE Main button will illuminate.
8. Enter interactive calibration mode by **sending SCPI command:**  
`CAL:MON:CURR`
9. Press on the terminal keys - or + to reduce or increase the monitoring value. Adjust the monitoring value displayed on the voltmeter that was set up in Step 1 to read as close as possible to 4.000 V.
10. Press any key other than the + or - keys to exit from interactive calibration mode.

## Non-isolated Voltage Programming of Voltage Calibration

---

**Important:** For maximum accuracy at a specific APG level, follow the calibration procedure again but use the intended operating voltage level in steps 3 and 4.

---

### To calibrate the non-isolated voltage programming of voltage:

1. Disconnect the load and connect the voltmeter to the output.
2. Connect the input voltage source to the non-isolated connector, voltage programming (J1.9 - J1.7).
3. Set the Voltage APG level to 4 V. Send the SCPI command:

```
SYST:COMM:APR:LEV 4
```

4. Set input source voltage to 4.000 V.
5. Set the input source as Voltage Non-Isolated for Voltage Programming. The SCPI command is:

```
SYST:REM:SOUR AVOL
```

6. Turn the main output to On by pressing the OUTPUT ENABLE Main button on the front panel or send the command:

```
:OUTP ON
```

The OUTPUT ENABLE Main button will illuminate.

7. Enter the interactive calibration mode by sending the SCPI command:

```
CAL:OUTP:ANAL
```

8. Press the terminal keys - or + to reduce or increase the main output voltage value. Adjust the main output voltage to 100%, measured on the external voltmeter on the output.
9. Press any key other than the + or - keys to exit from interactive calibration mode.

---

## Non-isolated Resistive Programming of Voltage Calibration

---

**Important:** For maximum accuracy at a specific APG level, follow the calibration procedure again but use the intended operating resistance level in steps 2 and 3.

---

### To calibrate the non-isolated resistive programming of voltage:

1. Disconnect the load and connect the voltmeter to the output.
2. Connect the 4.000k $\Omega$  resistor to the non-isolated connector, resistive programming of voltage, and voltage programming (J1.9-J1-11, and J1.7).
3. Set the resistive APG level to 4k $\Omega$ . The SCPI command is:  
`SYST:COMM:APR:LEV 4`
4. Set the input source as Resistive Non-Isolated for Voltage Programming. The SCPI command is:  
`SYST:REM:SOUR ARES`
5. Turn the main output On by pressing the OUTPUT ENABLE Main button on the front panel or send the command:  
`:OUTP ON`  
The OUTPUT ENABLE Main button will illuminate.
6. Enter the interactive calibration mode by sending the SCPI command:  
`CAL :OUTP:ANAL:RES`
7. Press the terminal keys - or + to reduce or increase main output voltage value. Adjust the main output voltage to 100%.
8. Press any key other than the + or - keys to exit from interactive calibration mode.

## Non-isolated Voltage Programming of Current Calibration

---

**Important:** For maximum accuracy at a specific APG level, follow the calibration procedure again but use the intended operating voltage level in steps 3 and 4.

---

### To calibrate the non-isolated voltage programming of current:

1. Short the main output with a shunt. Connect a multimeter to measure the voltage across the shunt.
2. Connect the input voltage source to the non-isolated connector, current programming (J1.10 - J1.7).
3. Set the Voltage APG level to 4 V. The SCPI command is:  
`SYST:COMM:APR:LEV:CURRE 4`
4. Set the input source voltage to 4.000 V.
5. Set the input source as Voltage Non-Isolated for Current. The SCPI command is:  
`SYST:REM:SOUR:CURRE AVOL`
6. Turn the main output On by pressing the OUTPUT ENABLE Main button on the front panel or send the command:  
`:OUTP ON`  
The OUTPUT ENABLE Main button will illuminate.
7. Enter the interactive calibration mode by sending the SCPI command:  
`CAL:OUT P:ANAL:CURRE`
8. Press the terminal keys - or + to reduce or increase the main output current value. Adjust the main output current to 100%.
9. Press any key other than the + or - keys to exit from interactive calibration mode.

## Non-isolated Resistive Programming of Current Calibration

**Important:** For maximum accuracy at a specific APG level, follow the calibration procedure again but use the intended operating resistance level in steps 2 and 3.

### To calibrate the non-isolated resistive programming of current:

1. Short the main output with a shunt. Connect a multimeter to measure the voltage across the shunt.
2. Connect the 4.000 k $\Omega$  resistor to the non-isolated connector (APG -J1), one terminal to resistive programming of current (J1 .12) and voltage programming of current (J1.10), and the other terminal to the common (J1.7).
3. Set the resistive APG level to 4 k $\Omega$ . The SCPI command is:  
`SYST:COMM:APR:LEV:CURR 4`
4. Set the input source as Resistive Non-Isolated for Current Programming. The SCPI command is:  
`SYST:REM:SOUR:CURR ARES`
5. Turn the main output to On by pressing the OUTPUT ENABLE Main button on the front panel or send the command:  
`:OUTP ON`  
 The OUTPUT ENABLE Main button will illuminate.
6. Enter the interactive calibration mode by sending the SCPI command:  
`CAL:OUTP:ANAL:CURR:RES`
7. Press the terminal keys - or + to reduce or increase the main output current value. Adjust the main output current to 100%.
8. Press any key other than the + or - keys to exit from interactive calibration mode.

## Calibration Procedure for Isolated Modes

The main output and the non-isolated mode must be calibrated first.

### Isolated Voltage Monitoring Calibration

---

**Important:** For maximum accuracy at a specific APG level, follow the calibration procedure again but use the intended operating voltage level in steps 3 and 8.

---

#### To calibrate the isolated voltage monitoring:

1. Disconnect the load and connect the voltmeter to the output.
2. Connect the voltmeter to the isolated voltage monitoring output lines (J3.5 - J3.6).
3. Set the Voltage APG level to 4 V. The SCPI command is:  
`SYST:COMM:APR:LEV 4`
4. Set the input source to local for voltage analog programming. The SCPI command is:  
`SYST:REM:SOUR LOC`
5. Set the main output voltage to 100% by sending the command:  
`SOUR:VOLT <ModelVolt>`  
or use the rotary adjust/Enter control.
6. Turn the main output to On by pressing the OUTPUT ENABLE Main button on the front panel or send the command:  
`:OUTP ON`  
The OUTPUT ENABLE Main button will illuminate.
7. Enter the interactive calibration mode by sending the SCPI command:  
`CAL:MON:ISOL`
8. Press the terminal keys - or + to reduce or increase the monitoring value. Adjust the monitoring value displayed on the voltmeter that was setup in Step 1 to read as close as possible to 4.000 V.
9. Press any key other than the + or - keys to exit from interactive calibration mode.



## Isolated Current Monitoring Calibration

**Important:** For maximum accuracy at a specific APG level, follow the calibration procedure again but use the intended operating voltage level in steps 3 and 8.

### To calibrate the isolated current monitoring:

1. Short the main output with a shunt. Connect a multimeter to measure the voltage across the shunt.
2. Connect the voltmeter to the Isolated monitoring output lines (J3.10 and J3.6).
3. Set the current APG level to 4 V. The SCPI command is:  
`SYST:COMM:APR:LEV:CURR 4`
4. Set the input source to local for voltage analog programming. the SCPI command is:  
`SYST:REM:SOUR:CURR LOC`
5. Set the main output voltage to 100% by sending the command:  
`SOUR:VOLT <ModelVolt>`  
 or use the rotary Adjust/Enter control.
6. Turn the main output to On by pressing the OUTPUT ENABLE Main button on the front panel or send the command:  
`:OUTP ON`  
 The OUTPUT ENABLE Main button will illuminate.
7. Enter the interactive calibration mode by sending the SCPI command:  
`CAL:MON:CURR:ISOL`
8. Press the terminal keys - or + to reduce or increase the monitoring value. Adjust the monitoring value displayed on the voltmeter that was set up in Step 1 to read as close as possible to 4.000 V.
9. Press any key other than the + or - keys to exit from interactive calibration mode.

## Isolated Voltage Programming of Voltage Calibration

---

**Important:** For maximum accuracy at a specific APG level, follow the calibration procedure again but use the intended operating voltage level in step 3.

---

### To calibrate the isolated voltage programming of voltage:

1. Disconnect the load and connect the voltmeter to the output.
2. Connect the input voltage source to the Isolated connector (J3.3 and J3.6).
3. Set the Voltage APG level to 4 V. The SCPI command is:  
`SYST:COMM:APR:LEV 4`
4. Set the input source voltage to 4.000 V.
5. Set the input source as Voltage Isolated for Voltage. The SCPI command is:  
`SYST:REM:SOUR AVOL`
6. Turn the main output to On by pressing the OUTPUT ENABLE Main button on the front panel or send the command:  
`:OUTP ON`  
The OUTPUT ENABLE Main button will illuminate.
7. Enter the interactive calibration mode by sending the SCPI command:  
`CAL :OUTP:ANAL:ISOL`
8. Press on the terminal keys - or + to reduce or increase the main output voltage value. Adjust the main output voltage to 100%.
9. Press any key other than the + or - keys to exit from interactive calibration mode.

## Isolated Resistive Programming of Voltage Calibration

**Important:** For maximum accuracy at a specific APG level, follow the calibration procedure again but use the intended operating resistance level in step 3.

### To calibrate the isolated resistive programming of voltage:

1. Disconnect the load and connect the voltmeter to the output.
2. Connect the 4.000 k $\Omega$  resistor to the isolated connector. One terminal to resistive programming of voltage (J3.8), and voltage programming of voltage (J3.3), and the other to common (J3.2).
3. Set the resistive APG level to 4 k $\Omega$ . The SCPI command is:  

```
SYST:COMM:APR:LEV 4
```
4. Set input source as Resistive Isolated for Voltage Programming. The SCPI command is:  

```
SYST:REM:SOUR IAR
```
5. Turn the main output to On by pressing the OUTPUT ENABLE Main button on the front panel or send the command:  

```
:OUTP ON
```

The OUTPUT ENABLE Main button will illuminate.
6. Enter the interactive calibration mode by sending the SCPI command:  

```
CAL :OUTP:ANAL:RES:ISOL
```
7. Press on the terminal keys - or + to reduce or increase the main output voltage value. Adjust the main output voltage to 100%.
8. Press any key than the + or - keys to exit from interactive calibration mode.

## Isolated Voltage Programming of Current Calibration

---

**Important:** For maximum accuracy at a specific APG level, follow the calibration procedure again but use the intended operating voltage level in step 3.

---

### To calibrate the isolated voltage programming of current:

1. Short the main output with a shunt. Connect a multimeter to measure the voltage across the shunt.
2. Connect the input voltage source to the Isolated connector (J3.4 -J3.6).
3. Set the Current APG level to 4 V. The SCPI command is:  
`SYST:COMM:APR:LEV:CURR 4`
4. Set the input source voltage to 4.000 V.
5. Set the input source as Voltage Isolated for Current. The SCPI command is:  
`SYST:REM:SOUR:CURR IAV`
6. Turn the main output to On by pressing the OUTPUT ENABLE Main button on the front panel or send the command:  
`:OUTP ON`  
The OUTPUT ENABLE Main button will illuminate.
7. Enter the interactive calibration mode by sending the SCPI command:  
`CAL :OUTP:ANAL:CURR:ISOL`
8. Press the terminal keys - or + to reduce or increase the main output current value. Adjust the main output current to 100%.
9. Press any key other than the + or - keys to exit from the interactive calibration mode.

## Isolated Resistive Programming of Current Calibration

### To calibrate the isolated resistive programming of current:

1. Short the main output with a shunt. Connect a multimeter to measure the voltage across the shunt.
2. Connect the 4.000 k $\Omega$  resistor to the isolated connector. One terminal to resistive programming of current (J3.7), and voltage programming of current (J3.3), and the other to common (J3.2).
3. Set the Resistive APG level to 4 k $\Omega$ . The SCPI command is:  
`SYST:COMM:APR:LEV:CURR 4`
4. Set the input source as Resistive Isolated for Current Programming. The SCPI command is:  
`SYST:REM:SOUR:CURR IAR`
5. Turn the main output On or send the command:  
`:OUTP ON`
6. Enter the interactive calibration mode by sending the SCPI command:  
`CAL:OUTP:ANAL:CURR:RES:ISOL`
7. Press the terminal keys - or + to reduce or increase the main output current value. Adjust the main output current to 100%.
8. Press any key other than the + or - keys to exit from the interactive calibration mode.

## Calibrating the Input Voltage APG Signal

The input voltage APG calibration is necessary to ensure accurate measurements when using the :MEAS : APR? and :MEAS : APR: ISOL? SCPI command queries to monitor the APG input signal.

### Gain Calibration

#### To calibrate the VAP APG input gain:

1. Connect a voltmeter and a DC voltage source to the non-isolated voltage APG input lines (J1.9 and J1.7).
2. Turn the power supply On.
3. Set the Voltage APG level to 4 V.  
Send the SCPI command: `SYST:COMM:APR:LEV 4`
4. Set the input source as Voltage analog APG. Send the SCPI command: `SYST:REM:SOUR:VOLT AVOL`
5. Set the voltage source attached to the non-isolated voltage APG input to 90% of the nominal voltage level, in this case 3.6 V.
6. Turn the output power on.
7. The power supply starts up in Constant Voltage mode.
8. Read the input voltage value from the voltmeter connected in step 1.
9. Type the SCPI input Voltage calibration command with voltage noted in step 8 as the parameter "data".  
For example, you would type `:CAL: INP : ANAL 3.53` if you were reading 3.53 volts from the voltmeter.

### Offset Calibration

Offset calibration of the power supply provides the best accuracy in low-range input voltage.

#### To perform offset calibration:

1. Set the voltage source attached to the non-isolated Voltage APG input to 10% of the nominal voltage level, in this case 0.400 V.
2. Turn on the output power.
3. Read the input voltage value from the voltmeter connected in step 1 of the gain calibration.

4. Type SCPI input Voltage calibration command with voltage noted in step 3 as the parameter “data”.

For example, you would type :CAL:INP:ANAL:CURR 0 . 4 3 if you read 0.43 volts from the voltmeter.

After performing offset calibration, it is highly recommended that you repeat gain calibration.

#### SCPI Command

```
[:]CALibration[<channel>]:INPut:ANALog[:VOLTage]
{<voltmeter reading in volts>}
```

## Calibrating the Input Current APG Signal

The input voltage APG calibration is necessary to ensure accurate measurements when using the :MEAS:APR? and :MEAS:APR:ISOL? SCPI command queries to monitor the APG input signal.

### Gain Calibration

#### To calibrate the CAP APG input gain calibration:

1. Connect a short across the power supply output.
2. Connect a voltmeter and a DC voltage source to the non-isolated current APG input lines (J1. 10 and J1 .7).
3. Turn the power supply On.
4. Set the Current APG level to 4 V. Send the SCPI command:  
SYST:COMM:APR:LEV:CURR 4
5. Set the input source as Voltage analog APG. Send the SCPI command: SYST:REM: SOUR: CURR AVOL
6. Set the voltage source attached to the non-isolated current APG input to 90% of the nominal current level, in this case 3.6 V.
7. Turn the output power on.
8. The power supply starts up in Constant Current mode.
9. Read the input voltage value from the voltmeter connected in step 2.
10. Type the SCPI input current calibration command with voltage noted in step 9 as the parameter “data”.  
For example, you would type :CAL:INP:ANAL:CURR 3.49 if you were reading 3.49 volts from the voltmeter.

## Offset Calibration

Offset calibration of the power supply provides the best accuracy in low-range input current.

### To perform offset calibration:

1. Set the voltage source attached to the non-isolated current APG input to 10% of the nominal current level, in this case 0.400 V.
2. Turn the output power on.
3. Read the input voltage value from the voltmeter connected in step 2 of the gain calibration.
4. Type SCPI input current calibration command with voltage noted in step 3 as the parameter “data”.

For example, you would type `:CAL:INP:ANAL:CURR 0.43`.

After performing offset calibration, it is highly recommended that you repeat gain calibration.

### SCPI Command

```
[:]CALibration[<channel>]:INPut:ANALog:CURRent{<voltmeter reading in volts>}
```



## Storing and Loading Calibration Parameters

It is recommended that you save all the calibration parameters in a text file so they can be reloaded in the event of a flash failure or a mistake in calibration.

**To get the calibration data, execute the following commands and save the response in a text file:**

**The SCPI command (s) to download all the calibration data are:**

```
[:]CALibration:PARAmeter[:OUTPut]
[:]CALibration:PARAmeter:APROgram?
[:]CALibration:PARAmeter:INPut?
```

The response to these commands are in the 488.2 Arbitrary Program Block Data format.

If the calibration ever needs to be restored, you can execute the same commands and write the arbitrary block data response that was received in the query as the parameter.

For example, downloading the parameter data can be done from the hyper terminal as follows.

```
:cal:par?
#2 62#h2710, #h0000, #h2710, #h0000, #h2710, #h0000, #h2710,
#h0000, #h1AA4
:cal:par:apr?
#259#h7B, #h7F, #h7F, #h7F, #h7F, #h7F, #h7F, #h7F, #h7F, #h7F,
#h 7F, #h7F
:cal:par:inp?
#227#h2710, #h00, #h2710, #h00
```

**To restore the unit with a set of previously saved calibration values can be done as follows.**

```
:cal:par
#262#h2710, #h0000, #h2710, #h0000, #h2710, #h0000, #h2710, #h0
000, #h1AA4
:cal:par:apr
#259#h7F, #h7F, #h7F, #h7F, #h7F, #h7F, #h7F, #h7F, #h7F, #h7F, #h7
F, #h7F
:cal:par:inp
#h227#h2710, #h00, #h2710, #h00
```

By saving and reloading the calibration parameters using these commands, you can calibrate the unit for maximum accuracy for a specific load and then switch loads and load a calibration set that is accurate at maximum accuracy for the new load.

## Restore Factory Calibration

To restore factory calibration, use the SCPI command for returning the power supply to factory calibration settings.

**The SCPI Command (s) for these instructions are:**

```
[:]CALibration:REStore
```

## Restore Default Calibration

To restore default calibration (unit gain and zero offset for all calibration parameters), use the SCPI command for returning the power supply to default calibration settings. This can be useful when recalibrating the unit to a specific load but causes ALL calibration values to return to default values. All types of calibration must be done to restore the unit to fully functional condition. It is strongly recommended that the calibration coefficients be saved before using this command. (See “Storing and Loading Calibration Parameters” on page 7-25).

**The SCPI Command (s) for these instructions are:**

```
[:]CALibration:DEFault
```

## User Diagnostics

If your power supply is not performing as described in this Manual, read through the procedures and checks in this chapter before calling your service technician. These procedures are limited to operator level functions only. They do not require cover-off servicing of the unit.

## Emergency Shutdown

**In an emergency, carry out these steps:**

1. Shut the power supply OFF immediately.
2. Disconnect the mains supply.
3. Disconnect the power supply from the load.

## Unusual or Erratic Operation

**If the power supply displays any unusual or erratic operation, follow these steps:**

1. Shut the power supply OFF immediately.
2. Disconnect the power supply from the load and external programming.
3. Test the power supply with no load, running the tests in “Step 5: Performing Functional Tests” on page 2-10.
4. If the tests show that the power supply is functioning normally, check all load, programming, and monitoring connections and circuits.
5. Check the AC input for correct voltage and frequency.

If the problem is not solved after you have followed this procedure, or if the unit fails to operate correctly upon retesting, call your service technician.

## Troubleshooting for Operators

Refer to Table 6-1 to ensure that the power supply is configured and connected for normal operation. If you require any further troubleshooting assistance, call your service technician. See “Contact Information” on page i.

**Table 7-1** Troubleshooting

Symptom	Check	Further Checks and Corrections
The power supply is not operating. <i>FLA FAIL</i> is displayed.	Flash memory check sum error.	Do a reset. See page 3-40.

---

**Important:** The power supply will boot with default options and calibration values.

---

# A

## **SCPI Command Reference**

Appendix A, SCPI Command Reference, provides a summary of the Standard Commands for Programmable Instruments (SCPI) that are supported by the XG and XTR Family Programmable DC Power Supply.

## SCPI Conformance Information

### Codes and Standards

This power supply conforms to the following international standards:

- IEEE Std. 488.2-1992, “IEEE Standard Codes, Formats, Protocols, and Common Commands For Use With IEEE Std. 488.1-1987”
- IEEE Std. 488.1-1987 “IEEE Standard Digital Interface for Programmable Instrumentation”
- TIA/EIA-232F
- Standard Commands for Programmable Instruments (SCPI) Version 1999.0

### IEEE 488.2 Requirements

GPIB control implements all IEEE 488.2 requirements.

### SCPI Requirements

The power supply conforms to the following SCPI requirements:

- SCPI mandated commands
- Questionable Status Register (QSR), Condition, Event, Enable
- Operation Status Register (OSR), Condition, Event, Enable
- Status Byte Register (SBR)
- Standard Event Status Register (SESR)

### IEEE 488.2/SCPI Syntax and Style

#### Parameters: Units of Measure and Multipliers

Refer to IEEE 488.2, section 7.7.3 for the definition of units of measure. The default units of measure include:

- V (Volt - voltage)
- A (Ampere - current)
- W (Watt - power)
- S (seconds - time)

These units are only supported as defaults. To place the unit in the command will cause an error to be pushed into the error queue.

## SCPI Command Hierarchy

SCPI is an ASCII-based command language designed for use in test and measurement equipment. The command structure is organized around common roots, or nodes, which are the building blocks of SCPI subsystems. An example of a common root is CALibration, and some of the commands that reside in the CALibration subsystem are:

```
[:]CALibration
  [:OUTPut]
    [:VOLTage]
      [:DATA] <NR1>
    :CURRent
      [:DATA] <NR1>
```

CALibration is the root keyword of the command. OUTPut is a second-level keyword, and VOLTage and DATA are third-level keywords. A colon (:) is used to separate a command keyword from a lower-level keyword.

**A**

## Using SCPI Commands

This Manual shows SCPI commands in the following format:

```
CALibration:CURRent:LEVel {<current>|MIN|MAX}
```

The command is expressed as a mixture of upper- and lowercase letters. The uppercase letters suggest how the command can be abbreviated into a short form. SCPI commands can be sent in long or short forms. The short form is better for data entry. The long form is better for readability.

Command strings are not case sensitive: `CURR`, `Curr`, and `curr` are all acceptable abbreviations for `CURRent`. As for the long form, `CURRENT`, `Current`, and `current` are all acceptable. It is not possible to write for example, `CALibrat:CURR:LEV` because the extra first node does not explicitly match the short or long form of the calibration node.

The command strings include punctuation. While some punctuation is sent with the string, other markings are used to identify different elements of the command syntax and are not sent with the string.

The following punctuation is sent with the command string:

- **Colons (:)** separate command keywords from lower-level keywords. For example, `CAL : CURR: STAT`.
- **Blank spaces** separate command keywords from parameter values. For example, `CURR 0.1`.
- **Commas** separate parameters from each other when more than one parameter is sent in the same string. For example, `CAL: STAT OFF,"1234."`
- **Semicolons (;)** separate multiple commands from the same subsystem. This allows for greater efficiency.

For example: `CAL:CURR:LEV MIN;VOLT:LEV MIN`

is the same as typing:

```
CAL:CURR:LEV MIN
CAL: VOLT: LEV MIN
```

- **Colons and semicolons** can be used together to link commands from different subsystems. For example:

```
CAL:CURR:LEV MIN;:MEAS:CURR?
```

The short form is made up of 3 or 4 letters. There can only be an absolute short or long form. For example, it is not possible to write `CALibrat:CURR:LEV` because the extra the first node does not match explicitly the short or long form of the calibration node.



The following punctuation is not sent with the command string:

- **Braces** ( { } ), or curly brackets, identify a selection of choices. Choose one of the enclosed values.
- **Vertical bars, or pipes**, ( | ) can be read as “or” and is used to separate the choices found within the braces.
- **Angle brackets** ( < > ) identify where specific values must be entered for a parameter. For example, in the example at the top of the page, the parameter <current> appears in the command string. To set the current set point to 0.1 A, the syntax is `CAL:CURR:LEV 0.1`.
- **Square brackets** ( [ ] ) identify optional parameters. If an optional parameter is not sent with the command string, a default parameter is sent in its place.

### Using Minimum and Maximum

In the following example, Minimum and Maximum are offered as alternative choices to declaring a specific parameter value.

```
CAL:CURRent:LEVel {<current>|MIN|MAX}
```

The string `CAL:CURR:LEV MIN` sets the current calibration level to the minimum model value.

### Using Queries

A question mark lets you query the present value for most parameters. For example, to query the current calibration state use:

```
CAL:SEC:STAT?
```

You can also use the following to query minimum and maximum allowed values for most parameters:

```
:VOLT? MIN
:VOLT? MAX
```

---

**Important:** If you send two queries, it is best to read and respond to the first response before trying to read the second. Otherwise, you may receive an incomplete first response followed by a complete second response. To avoid this, you can either wait for and read the first response before sending the second query, or send a device clear message before sending the second query.

---

## Terminating Characters

Every command string must end with a terminating <new line> character. It is also acceptable to use a <carriage return> followed by a <new line>. Terminating a command string always resets the SCPI command path to the root level.

## Common Commands

The IEEE-488.2 standard includes a set of common commands for functions such as reset and self-test. These common commands always start with an asterisk (\*), contain 4 or 5 characters, and may have one or more parameters. The command is always separated from the parameter by a blank space. Multiple commands sent in the same string are separated by a semi-colon (;). The following is an example of how 3 common commands can be sent together in the same string:

```
*OPC; *PSC Off; *TRG
```

## Parameter Types

Several different data types are defined for use in program messages and response messages.

### Boolean Parameters

Boolean parameters are single binary conditions such as 1 and 0, or ON and OFF. The following is an example of a command that uses Boolean parameters:

```
SYST:COMM:GPIB:PONS {ON|OFF|1|0}
```

### Discrete Parameters

Discrete parameters are used when program settings have a limited number of values. If you query a discrete parameter, the response will always be in the short form with all uppercase letters. The following is an example of a command that uses discrete parameters:

```
TRIG:SOUR {BUS|EXT|IMM|NONE}
```

### Numeric Parameters

Numeric parameters are number representations such as decimal points, optional signs, and scientific notation. Values such as MINimum and MAXimum are accepted as substitutes for numbers. When DEFault is provided as a parameter, the machine selects the default value automatically. No units' suffix should be included with the parameter, only support for defaults units is available. In cases where specific numeric values are accepted, the power unit will round the input parameters. The following is an example of a command that uses numeric parameters:

```
VOLT:PROT {<voltage>|MAX|MIN}
```

### String Parameters

String parameters are used when a series of ASCII characters is required. Strings must be enclosed within single or double quotations. The beginning and ending quotation marks must be matching. Quote delimiters may be included in the string by typing the quotation marks twice without any characters in between. The following is an example of a command that uses string parameters:

## SCPI Command Tree

The SCPI commands are organized into a tree structure. To illustrate the tree structure, the following tree has been provided. Each level of indentation presents a branch. The command to execute can then be found by following the tree from the root or farthest left node all the way down to the leaf node.

For example, to do the analog isolated programming command, start at the [:]CALibration root node, go through the :OUTPut node and then move down past the [:VOLTage] and :CURRent nodes which appear at that level to the :ANALog node and then move through the optional [:VOLTage] node to the :ISOLated node.

Thus, the command would then be

```
[:]CALibration:OUTPut:ANALog[:VOLTage]:ISOLated
```

All commands can be formed by looking at this tree and taking the unique path from the root node to the leaf node. Table A-1 on page A-14 shows all the commands fully formed with parameters.

### **[:]CALibration**

```

:PARameter
  :APRogram
  :INPut
  [:OUTPut]
:INPut
  :ANALog
    [:VOLTage]
    :CURRent
:OUTPut
  [:VOLTage]
  :CURRent
:MONitor
  [:VOLTage]
    :ISOLated
  :CURRent
    :ISOLated
:ANALog
  [:VOLTage]

```

```

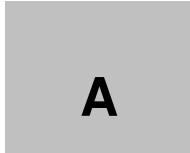
        :ISOLated
        :RESistive
            :ISOLated
    :CURRent
        :ISOLated
        :RESistive
            :ISOLated
[:VOLTage]
    :PROTection
        [:OVER]
:REStore
:DEFault
[:]INITiate
    [:IMMediate]
[:]MEASure
    :AProgram
        [:VOLTage]
            [:DC]
            :ISOLated
                [:DC]
        :CURRent
            [:DC]
            :ISOLated
                [:DC]
    [:SCALar]
        [:VOLTage]
            [:DC]?
        :CURRent
            [:DC]?
[:]OUTPut
    :PROTection
        :CLEar
        :FOLDback
            [:MODE]
        :DELay

```

```

        :LATCh
:POLarity
[:POWER]
    [:STATe]
    :PowerON
        [:STATe]
:AUXilliary
    [:STATe]
    :PowerON
        [:STATe]
[ : ] PROGram
    :READback
    :STATe
    [:RECORD]
        :START
        :STOP
    :DELeTe
        [:ALL]
    :REPeat
    [:STEP]
        :DWELL
[ : ] SOURce
    :COMBine
        :CSHare
            [:MODE]
:VOLtage
    [:LEVEL]
        [:IMMediate]
            [:AMPLitude]
    :PROTection
        [:OVERvoltage]
            [:LEVel]
        :UNDer
            [:LEVel]
:CURRent

```



```
    [:LEVEL]
      [:IMMEDIATE]
        [:AMPLITUDE]

[:]SENSe:
  :PROTECTION
    :INTERLOCK
      [:STATE]
    :TEMPERATURE
      [:LATCH]

[:]STATus
  :PRESET
  :QUESTIONABLE
    [:EVENT]?
    :ENABLE
    :CONDITION?
    :PTRANSITION
    :NTRANSITION
  :VOLTAGE
    [:EVENT]?
    :ENABLE
    :CONDITION?
    :PTRANSITION
    :NTRANSITION
  :TEMPERATURE
    [:EVENT]?
    :ENABLE
    :CONDITION?
    :PTRANSITION
    :NTRANSITION
  :OPERATION
    [:EVENT]?
    :ENABLE
    :CONDITION?
    :PTRANSITION
```

```

:NTRansition
:CSHare
  [:EVENT]?
  :ENABle
  :CONDition?
  :PTRansition
  :NTRansition
:SHUTdown
  [:EVENT]?
  :ENABle
  :CONDition
  :PTRansition
  :NTRansition
  :PROTectioN
    [:EVENT]?
    :ENABle
    :CONDition?
    :PTRansition
    :NTRansition
:STANdard
  [:EVENT]?
  :ENABle
:CLEar
:SBYTE
  [:EVENT]?
:SREQuest
  [:ENABle]
[:]SYSTem
:FPANel
  [:TIMEout]
:PROTectioN
  :LATCh
  [:MASK]
:RESet
:WAIT

```



```
:TEST?
:RESet
:IDENtify?
:REMOte
  :STATe
  :SOURce
    [:VOLTage]
    :CURRent
:COMMunicate
  :APROgram
    :LEVel
      [:VOLTage]
      [:ISOLated]
    :CURRent
      [:ISOLated]
  [:MCHannel]
    :ADDRESS
:PON
  :VOLT
  :CURR
  :ENA
    :VOLT
    :CURR
:SAVE
:RECall
:VERSion?
:ERRor
  [:NEXT]?
  :CODE
  [:NEXT]?
  :COUNT?
:HELP
  [:HEADers]?
  :SYNTAX?
  :LEGacy?
```

## SCPI Command Summary

The SCPI commands supported by this programmable power supply are described in the tables in the remainder of this section. These tables use the following column headings:

- **Function** The commonly used name for the function.
- **SCPI Command** The full command in long form.

**Description** Explains what the command does or what is affected by it.

Query? Indicates whether the unit supports a query version of the listed command. N/A indicates Not applicable. (The command has no query form and will respond with an error if queried.)

**Table A-1** IEEE 488.2 Commands

Function	SCPI Command	Description	Parameter and Range	Query
Select Address	*ADR	Select the power supply unit to communicate with.	?!<Address (1–30)>	Yes
Clear Status	*CLS [:]STATUS [<channel>]:CLEAR	Clears all the status data structures.		N/A
Query the Error Queue	*ERR	Query the Error Queue for the oldest error event.		
Standard Event Status Enable Query	*ESE? [:]STATUS [<channel>]:STANDARD:ENABLE	Query the Standard Event Status Enable register settings.		Yes
Standard Event Status Enable	*ESE [:]STATUS [<channel>]:STANDARD:ENABLE <ESE-word>	Set the Standard Event Status Enable Register bits.	<Enable Flags(0–255)>	N/A
Standard Event Status Register Query	*ESR? [:]STATUS [<channel>]:STANDARD[:EVENT]?	Query the Standard Event Status Register (SERS).		Yes

**Table A-1** IEEE 488.2 Commands (Continued)

Display All SCPI Command Headers	*HELP?	Display all the SCPI command headers available on this device.		Yes
Identification Query	*IDN? [:]SYSTem[<channel>]:IDENTify?	Query device identification string.		Yes
Operation Complete Command	*OPC	Operation Complete Command		N/A
Query Operation Complete Command	*OPC?	Operation Complete Query		Yes
Recall	*RCL OR [:]SYSTem[<channel>]:RECall <setting_location>	Recall a User Memory Setting. See *SAV below.	<Setting Index (1–5)>	N/A
Reset	*RST [:]SYSTem[<channel>]:RESet	Resets all values to default state (excluding calibration data).		N/A
Save User Settings	*SAV [:]SYSTem[<channel>]:SAVE <setting location>	Save a User Memory Setting.		N/A
Query Service Request Enable	*SRE? [:]STATus[<channel>]:SREQuest:ENABle?	Service Request Enable Query		Yes
Service Request Enable	*SRE [:]STATus[<channel>]:SREQuest:ENABle <status-enable>	Service Request Enable Command	<Enable Flags(0–255)>	N/A
Read Status Byte	*STB? [:]STATus[<channel>]:SBYTE[EVENT]?	Read the status byte.		Yes

**Table A-1** IEEE 488.2 Commands (Continued)

Trigger	*TRG	Trigger system		N/A
Self-Test Query	*TST? [:]SYSTem[<channel>]:TEST?	Perform unit Self Test (Pass=0).		Yes
Wait To Continue	*WAI [:]SYSTem[<channel>]:WAIT	Wait to continue command.		N/A

**Table A-2** Readback Commands

Function	SCPI Command	Description	Parameter and Range	Query
Read Output Current	[:]MEASure[<channel>][:SCALar]:CURRent[:DC]?	Measure and readback output current at the output terminals.		Yes
Read Output Voltage	[:]MEASure[<channel>][:SCALar][:VOLTagE][:DC]?	Measure and readback output voltage at the output terminals.		Yes
Read APG Input Voltage	[:]MEASurement[:SCALar]:APRogram[:VOLTagE][:DC]?	Measure and readback the voltage being input to the non isolated voltage analog programming input pin.		Yes
Read Isolated APG Input Voltage	[:]MEASurement[:SCALar]:APRogram[:VOLTagE]:ISOLated[:DC]?	Measure and readback the voltage being input to the isolated voltage analog programming input pin.		Yes
Read APG Input Voltage	[:]MEASurement[:SCALar]:APRogram:CURRent[:DC]?	Measure and readback the voltage being input to the non isolated current analog programming input pin.		Yes
Read APG Input Voltage	[:]MEASurement[:SCALar]:APRogram:CURRent:ISOLated[:DC]?	Measure and readback the voltage being input to the isolated current analog programming input pin.		Yes

**Table A-3** SCPI Commands for Output Control

Function	SCPI Command	Description	Parameter and Range	Query
Set Current Sharing Mode	[[[:]]SOURce[<channel>]:COMBine:CSHare[: MODE]	Set the unit to operate in the current share controller or slave mode. If only a single unit is being used it should be set to controller.	? CONTroller SLAVE	Yes
Set (Immediate) Current Set point	[[[:]]SOURce[<channel>]:CURRent[:LEVel][: IMMEDIATE][:AMPLitude]	Set current set point (immediate)	? <Current Set Point> MAXimum MINimum	Yes
Set (Immediate) Voltage Set point	[[[:]]SOURce[<channel>]:VOLTage[:LEVel][: IMMEDIATE][:AMPLitude]	Change voltage set point (immediate)	? <Voltage Set Point> MAXimum MINimum	Yes
Set Over Voltage Protection Level	[[[:]]SOURce[<channel>]:VOLTage:PROTect ion[:OVERvoltage][:LEVel]	Set the over voltage protection level.	? <OVP Set Point> MAXimum MINimum	Yes
Set Under Voltage Protection Level	[[[:]]SOURce[<channel>]:VOLTage:PROTect ion:UNDer[:LEVel]	Set the under voltage protection level.	? <UVP Set Point> MAXimum MINimum	Yes

**Table A-4 SCPI Commands for Calibration**

Function	SCPI Command	Description	Parameter and Range	Query
Restore Factory Calibration	[:]CALibration[<channel>]:REStore	Restores the calibration to the factory defaults.	N/A	N/A
Restore Default Calibration	[:]CALibration[<channel>]:DEFault	Restores the default calibration for all variables. (Unit gain and zero offset).	N/A	No
Calibrate OVP protection.	[:]CALibration[<channel>][:VOLTagE]:PROTection[:OVER]	Calibrate the over voltage protection.	<OVP Voltage Set in Volts>	No
Enter Output Voltage Data	[:]CALibration[<channel>]:OUTPut:VOLTagE	Sets the voltage output calibration level.	<Voltage set in volts>	No
Enter Output Current Data	[:]CALibration[<channel>]:OUTPut:CURRent	Sets the current output calibration level	<Current set in amps>	No
Calibrate the Voltage controlled Non Isolated Voltage APG feature	[:]CALibration[<channel>]:MONitor[:VOLTagE]	Calibrate the voltage monitor signal system.	?   <NR1>   <nothing for interactive mode>	Yes
Calibrate the Voltage controlled Isolated Voltage APG feature	[:]CALibration[<channel>]:MONitor[:VOLTagE]:ISOLated	Calibrate the isolated voltage monitor signal system.	?   <NR1>   <nothing for interactive mode>	Yes

**Table A-4** SCPI Commands for Calibration (Continued)

Calibrate the Voltage controlled Non Isolated Current APG feature	[:]CALibration[<channel>]:MONitor:CURRent	Calibrate the current monitor signal system.	?   <NR1>   <nothing for interactive mode>	Yes
Calibrate the Voltage controlled Isolated Current APG feature	[:]CALibration[<channel>]:MONitor:CURRent:ISOLated	Calibrate the isolated current monitor signal system.	?   <NR1>   <nothing for interactive mode>	Yes
Calibrate the Voltage APG Input	[:]CALibration:INPut :ANALog[:VOLTage]	Calibrates the isolated and non-isolated VA P measurement commands.	<? NR1>	Yes
Calibrate the Current APG Input	[:]CALibration:INPut :ANALog:CURRent	Calibrates the isolated and non-isolated CAP measurement commands.	<? NR1>	Yes
Calibrate the Voltage controlled Non Isolated Voltage APG feature	[:]CALibration[<channel>]:OUTPut:ANALog[:VOLTage]	Calibrate the voltage analog programming system.	?   <NR1>   <nothing for interactive mode>	Yes
Calibrate the Voltage controlled Isolated Voltage APG feature	[:]CALibration[<channel>]:OUTPut:ANALog[:VOLTage]:ISOLated	Calibrates the voltage analog programming system.	?   <NR1>   <nothing for interactive mode>	Yes

**Table A-4** SCPI Commands for Calibration (Continued)

Calibrate the Voltage controlled Non Isolated Current APG feature	[:]CALibration[<channel>]:OUTPut:ANALog:CURRent	Calibrate the current analog programming system.	?   <NR1>   <nothing for interactive mode>	Yes
Calibrate the Voltage controlled Isolated Current APG feature	[:]CALibration[<channel>]:OUTPut:ANALog:CURRent:ISOLated	Calibrates the current analog programming system.	?   <NR1>   <nothing for interactive mode>	Yes
Calibrate the Resistive controlled Non Isolated Voltage APG feature	[:]CALibration[<channel>]:OUTPut:ANALog[:VOLTage]:RESistive	Calibrate the Resistive controlled voltage analog programming system.	?   <NR1>   <nothing for interactive mode>	Yes
Calibrate the Resistive controlled Isolated Voltage APG feature	[:]CALibration[<channel>]:OUTPut:ANALog[:VOLTage] :RESistive:ISOLated	Calibrates the Resistive controlled voltage analog programming system.	?   <NR1>   <nothing for interactive mode>	Yes
Calibrate the Resistive controlled Non Isolated Current APG feature	[:]CALibration[<channel>]:OUTPut:ANALog:CURRent:RESistive	Calibrate the Resistive controlled current analog programming system.	?   <NR1>   <nothing for interactive mode>	Yes



**Table A-4** SCPI Commands for Calibration (Continued)

Calibrate the Resistive controlled Isolated Current APG feature	[:]CALibration[<channel>]:OUTPut :ANALog:CURRent:RESistive:ISOLated	Calibrates the Resistive controlled current analog programming system.	? <NR1> <nothing for interactive mode>	Yes
Get Input Calibration Parameters	[:]CALibration[<channel>]:PARAmeter [:INPut]	Queries and loads the input calibration parameters in arbitrary program block data format.	? <arbitrary program block data>	Yes
Get Output Calibration Parameters	[:]CALibration[<channel>]:PARAmeter [:OUTPut]	Queries and loads the output calibration parameters in arbitrary program block data format.	? <arbitrary program block data>	Yes
Get Analog Programming Calibration Parameters	[:]CALibration[<channel>]:PARAmeter :APROgram	Queries and loads the APG calibration parameters in arbitrary program block data format.	? <arbitrary program block data>	Yes

**Table A-5** SCPI Commands to Clear All Protection Mechanisms

Function	SCPI Command	Description	Parameter and Range	Query
Clear Output Protection	[:]OUTPut [<channel>]:PROTection:CLEAr	Clears the currently set alarms.		N/A

**Table A-6** SCPI Commands for Foldback Protection

Function	SCPI Command	Description	Parameter and Range	Query
Set Output Foldback Delay	[:]OUTPut [<channel>]:PROTection:FOLDback:DELAy	Set the delay time (seconds) before foldback protection is triggered.	?!<Delay - (0.5-50)>	Yes
Set Output Foldback Mode	[:]OUTPut [<channel>]:PROTection:FOLDback[:MODE]	Select condition for foldback.	?!CVICINONE	Yes

**Table A-7** SCPI Commands for Power

Function	SCPI Command	Description	Parameter and Range	Query
Shutdown Logic Control	[:]OUTPut:POLarity	Sets the TTL level that will trigger an External Shutdown.	?HIGHLOW	Yes
Main Output Control	[:]OUTPut[:POWER][:STATe]	Control Main Output State (Enable/Disable)	?IONIOFF	Yes
Power On Main Output Control	[:]OUTPut[:POWER]:PON[:STATe]	Control Main Output Autostart State (Enable/Disable)	?IONIOFF	Yes
Aux Output Control	[:]OUTPut:AUXilliary[:STATe]	Control Aux Output State (Enable/Disable)	?IONIOFF	Yes
Power Auxiliary Output Control	[:]OUTPut:AUXilliary:PON[:STATe]	Control Aux Output Autostart State (Enable/Disable)	?IONIOFF	Yes

**Table A-8** SCPI Commands for Triggering

Function	SCPI Command	Description	Parameter and Range	Query
Set Immediate Initiation of Trigger System	[:]INITiate[<channel>][:IMMediate]	Triggers the Autosequence Program.		N/A

**Table A-9** System Commands

Function	SCPI Command	Description	Parameter and Range	Query
Set the menu system timeout	[ : ] SYSTem:FPANel [ : TIMEout ]	Sets the menu system timeout.	<1–20 to one decimal place seconds>	Yes
Resets the Instrument to default values.	[ : ] SYSTem[<channel>]:RESet	Resets all values to default state (excluding calibration data).		N/A
Wait to Continue	[ : ] SYSTem[<channel>]:WAIT	Wait to continue command.		N/A
Self Test	[ : ] SYSTem[<channel>]:TEST?	Perform unit Self test, returns 0 if pass, non zero value for failure.		Yes
ID Query	[ : ] SYSTem[<channel>]:IDENtify	Query device ID string.		Yes
Save User Preset	[ : ] SYSTem[<channel>]:SAVE	Save the user preset values. Select any slot from 0-3.	<Setting Index (0-3)>	No
Recall User Preset (previously saved)	[ : ] SYSTem[<channel>]:RECall	Load the user preset values. Select any slot from 0-3.	<Setting Index (0-3)>	No
Query System Error	[ : ] SYSTem[<channel>]:ERRor [ : NEXT ] ?	Returns the next error in the instrument's error queue		Yes
Query System Error Code	[ : ] SYSTem[<channel>]:ERRor:CODE [ : NEXT ] ?	Returns the error code only for the next error in the instrument's error queue.		Yes

**Table A-9** System Commands (Continued)

Query the Error Queue for the number of entries.	[:]SYSTem[<channel>]:ERRor:COUnT?	Returns the number of errors currently in the error queue.		Yes
Select Voltage Analog Programming Input Voltage Input Level/Range	[:]SYSTem[<channel>]:COMMunicate:APROgram:LEVel[:VOLtagE][:ISOLated]	Select level for Voltage APG. Level can be between 2 -10 volts.	?<Level(2-10)> MAXimum MINimum	Yes
Select Current Analog Programming Input Voltage Input Level/Range	[:]SYSTem[<channel>]:COMMunicate:APROgram:LEVel:CURRent[:ISOLated]	Select level for Current APG. Level can be between 2 -10 volts.	?<Level(2-10)> MAXimum MINimum	Yes
Select the address to communicate with.	[:]SYSTem[<channel>]:COMMunicate[:MCHannel]:ADDRESS	Select the current device to receive the commands. The parameter for this command is the address set on the front panel under the remote		Yes
Setup the Voltage control APG source	[:]SYSTem[<channel>]:REMote:SOURce[:VOLtagE]	Alter or query the state of the remote programming voltage APG source.	? LOCAL AVOLtagE IAVOLTage ARESistive IAREsistive	Yes

**Table A-9** System Commands (Continued)

Setup the Current control APG source	[:]SYSTem[<channel>]:REMOte:SOURce:CURRent	Alter or query the state of the remote programming current APG source.	? LOCAL AVOLTage IAVOLTage AREsistive IAREsistive	Yes
Set Front Panel lock state.	[:]SYSTem[<channel>]:REMOte:STATe	Change front panel control mode	? LOCAL REMOte	Yes
Power On Voltage Low	[:]SYSTem[<channel>]:PON:VOLTage	Set the voltage set point to zero when the power is turned on.	? ON OFF	Yes
Power On Current Low	[:]SYSTem[<channel>]:PON:CURRent	Set the current set point to zero when the power is turned on	? ON OFF	Yes
Output Enable Voltage Low	[:]SYSTem[<channel>]:PON:ENAbLe:VOLTage	Set the voltage set point to zero when the output enable button is pressed.	? ON OFF	Yes
Output Enable Current Low	[:]SYSTem[<channel>]:PON:ENAbLe:CURRent	Set the current set point to zero when the output enable button is pressed.	? ON OFF	Yes
Query SCPI Version	[:]SYSTem[<channel>]:VERSion?	Returns the SCPI version to which the instrument complies. Format is YYYY.V		Yes
SCPI Help	[:]SYSTem[<channel>]:HELP[:HEADers]?	Query system for all supported SCPI command headers.		Yes
Legacy Help	[:]SYSTem[<channel>]:HELP:LEGacy?	Query the system for all supported legacy commands.		Yes
Alarm Masking	[:]SYSTem[<channel>]:PROTEction[:MASK]	Enable/disable alarms/protection.	? <Alarm Mask - (0–2047)	Yes

**Table A-9** System Commands (Continued)

Set Alarm Output Latches	[:]SYSTem[<channel>]:PROTection:LATCh	Sets the Alarm Output Latches. See Table 3-6 on page Table 3-6.	?l <Sum of output latch flags>	Yes
--------------------------	---------------------------------------	---	--------------------------------	-----

**Table A -10** Status Commands

Function	SCPI Command	Description	Parameter and Range	Query
Query Operation Status Condition Register	[:]STATus[<channel>]:OPERation:CONDition?	Query the Operations Condition Register. See Table 5-11 on page 5-40.		Yes
Set Operation Status Enable Register	[:]STATus[<channel>]:OPERation:ENABle	Access the Operations Enable Register. See Table 5-11 on page 5-40.	?l<Enable Flags -(0-65535)>	Yes
Query Operation Status Event Register	[:]STATus[<channel>]:OPERation[:EVENT]?	Query the Operations Event Register. See Table 5-11 on page 5-40.		Yes
Set Operation Status Negative Transition Register	[:]STATus[<channel>]:OPERation:NTRansition	Access the Operation Negative Trans Filter Register. See Table 5-11 on page 5-40.	?l<Transition Flags -(0-65535)>	Yes

**Table A-10** Status Commands (Continued)

Set Operation Status Positive Transition Register	[:]STATUS[<channel>]:OPERATION:PTRANSITION	Access the Operation Positive Trans Filter Register. See Table 5-11 on page 5-40.	?!<Transition Flags - (0-65535)>	Yes
Query Operation Status Shutdown Condition Register	[:]STATUS[<channel>]:OPERATION:SHUTDOWN:CONDITION?	See Table 5-12 on page 5-41.	Query the Operation Shutdown Condition Register	Yes
Set Operation Status Shutdown Enable Register	[:]STATUS[<channel>]:OPERATION:SHUTDOWN:ENABLE	Access the Operation Shutdown Enable Register. See Table 5-12 on page 5-41.	?!<Enable Flags - (0-65535)>	Yes
Query Operation Status Shutdown Event Register	[:]STATUS[<channel>]:OPERATION:SHUTDOWN[:EVENT]?	See Table 5-12 on page 5-41.	Query the Operation Shutdown Event Register	Yes
Set Operation Status Shutdown Negative Transition Register	[:]STATUS[<channel>]:OPERATION:SHUTDOWN:NTRANSITION	See Table 5-12 on page 5-41.	?!<Transition Flags - (0-65535)>	Yes



**Table A-10** Status Commands (Continued)

Set Operation Status Shutdown Positive Transition Register	[:]STATUS[<channel>]:OPERation:SHUTdown:PTRansition	Access the Operation Shutdown Positive Trans Filter Register. See Table 5-12 on page 5-41.	?!<Transition Flags - (0-65535)>	Yes
Query Operation Status Shutdown Protection Condition Register	[:]STATUS[<channel>]:OPERation:SHUTdown:PROTection:CONDition?	Query the Operation Shutdown Protection Condition Register. See Table 5-12 on page 5-41.		Yes
Set Operation Status Shutdown Protection Enable Register	[:]STATUS[<channel>]:OPERation:SHUTdown:PROTection:ENABle	Access the Operation Shutdown Protection Enable Register. See Table 5-12 on page 5-41.	?!<Enable Flags -(0-65535)>	Yes
Query Operation Status Shutdown Protection Event Register	[:]STATUS[<channel>]:OPERation:SHUTdown:PROTection[:EVENT]?	Query the Operation Shutdown Protection Event Register. See Table 5-12 on page 5-41.		Yes
Set Operation Status Shutdown Protection Negative Transition Register	[:]STATUS[<channel>]:OPERation:SHUTdown:PROTection:NTRansition	Register. See Table 5-12 on page 5-41.	?!<Transition Flags - (0-65535)>	Yes

**Table A-10** Status Commands (Continued)

Set Operation Status Shutdown Protection Positive Transition Register	[:]STATUS[<channel>]:OPERATION:SHUTDOWN:PROTECTION:PTRANSITION	Access the Operation Shutdown Protection Positive Trans Filter Register. See Table 5-12 on page 5-41.	?!<Transition Flags - (0-65535)>	Yes
Query Operation Status Event Register	[:]STATUS[<channel>]:OPERATION:CSHARE[:EVENT]?	Query the Operations Event Register. See Table 5-11 on page 5-40.		Yes
Set Operation Status Enable Register	[:]STATUS[<channel>]:OPERATION:CSHARE:ENABLE	Access the Operations Enable Register. See Table 5-11 on page 5-40.	?!<Transition Flags - (0-65535)>	Yes
Query Operation Status Condition Register	[:]STATUS[<channel>]:OPERATION:CSHARE:CONDITION?	Query the Operations Condition Register. See Table 5-11 on page 5-40.		Yes
Set Operation Status Positive Transition Register	[:]STATUS[<channel>]:OPERATION:CSHARE:PTRANSITION	Access the Operation Positive Trans Filter Register. See Table 5-11 on page 5-40.	?!<Transition Flags - (0-65535)>	Yes
Set Operation Status Negative Transition Register	[:]STATUS[<channel>]:OPERATION:CSHARE:NTRANSITION	Access the Operation Negative Trans Filter Register. See Table 5-11 on page 5-40.	?!<Transition Flags - (0-65535)>	Yes

**Table A-10** Status Commands (Continued)

Preset Enable, Positive Transition and Negative Transition Status Registers	[:]STATUS[<channel>]:PRESet	Restores the configuration of the SCPI status registers to known reporting conditions, IE Transition registers and enable register. See “Status Reporting in SCPI” on page 5-29 for more details.		
Query Questionable Status Register	[:]STATUS[<channel>]:QUESTionable { :EVENT } ?	Query the Questionable Status Register		Yes
Set Questionable Status Enable Register	[:]STATUS[<channel>]:QUESTionable :ENABle <status-enable> { ? }	Access the Questionable Status Register.		Yes
Query Questionable Status Condition Register	[:]STATUS[<channel>]:QUESTionable :CONDition?	Query the Questionable Status Register Condition		Yes
Set Questionable Status Negative Transition Register	[:]STATUS[<channel>]:QUESTionable :NTRansition	Access the Questionable Negative Trans Filter Register. See Table 5-15 on page 5-49.	?[<Transition Flags - (0-65535)>	Yes
Set Questionable Status Positive Transition Register	[:]STATUS[<channel>]:QUESTionable :PTRansition	Access the Questionable Positive Trans Filter Register. See Table 5-15 on page 5-49.	?[<Transition Flags - (0-65535)>	

Query Questionable Status Temperature Condition Register	[:]STaTus[<channel>]:QUEStionable :TEMPerature:CONDition?	Query the Questionable Temp Conditions Register. See Table 5-15 on page 5-49.		Yes
Set Questionable Status Temperature Enable Register	[:]STaTus[<channel>]:QUEStionable :TEMPerature:ENABle	Access the Questionable Temp Enable Register. See Table 5-15 on page 5-49.	?!<Enable Flags -(0- 65535)>	Yes

**Table A-10** Status Commands (Continued)

Query Questionable Status Temperature Event Register	[:]STATUS[<channel>]:QUESTionable:TEMPerature[:EVENT]?	Query the Questionable Temp Event Register. See Table 5-15 on page 5-49.		Yes
Set Questionable Status Temperature Negative Transition Register	[:]STATUS[<channel>]:QUESTionable:TEMPerature:NTRansition	Access the Questionable Temp Negative Trans Filter Register. See Table 5-15 on page 5-49.	?!<Transition Flags - (0-65535)>	Yes
Set Questionable Status Temperature Positive Transition Register	[:]STATUS[<channel>]:QUESTionable:TEMPerature:PTRansition	Access the Questionable Temp Positive Trans Filter Register. See Table 5-15 on page 5-49.	?!<Transition Flags - (0-65535)>	Yes
Query Questionable Status Voltage Condition Register	[:]STATUS[<channel>]:QUESTionable:VOLTage:CONDition?	See Table 5-15 on page 5-49.	Query the Questionable Voltage Condition Register	Yes
Set Questionable Status Voltage Enable Register	[:]STATUS[<channel>]:QUESTionable:VOLTage:ENABle	Access the Questionable Volt Enable Register. See Table 5-15 on page 5-49.	?!<Enable Flags - (0-65535)>	Yes

**Table A-10** Status Commands (Continued)

Query Questionable Status Voltage Event Register	[:]STATUS[<channel>]:QUESTIONABLE:VOLTAGE[:EVENT]?	Query the Questionable Volt Event Register. See Table 5-15 on page 5-49.		Yes
Set Questionable Status Voltage Negative Transition Register	[:]STATUS[<channel>]:QUESTIONABLE:VOLTAGE:NTRANSITION	Access the Questionable Voltage Negative Trans Filter Register. See Table 5-15 on page 5-49.	?[<Transition Flags - (0-65535)>	Yes
Set Questionable Status Voltage Positive Transition Register	[:]STATUS[<channel>]:QUESTIONABLE:VOLTAGE:PTRANSITION	Access the Questionable Voltage Positive Trans Filter Register. See Table 5-15 on page 5-49.	?[<Transition Flags - (0-65535)>	Yes
Query the Standard Event register (ESR?)	[:]STATUS[<channel>]:STANDARD[:EVENT]?	See Table 5-10 on 5-37. Same as *ESR.	Query the Standard Event Status Register (SERS).	Yes
Enable the Standard Event register (*ESE,*ESE?)	[:]STATUS[<channel>]:STANDARD:ENABLE	Access the Standard Event Status Register (SERS) Enable Flags. See Table 5-10 on page 5-37. Same as *ESE.	?[<Enable Flags - (0-255)>	Yes
Query the Status Byte (*STB)	[:]STATUS[<channel>]:SBYTE[:EVENT]?	Query the Status Byte. See Table 5-10 on page 5-37.		Yes

**Table A-10** Status Commands (Continued)

Service Request Enable (*SRE, *SRE ?)	[:]STATUS[<channel>]:SREquest:ENABLE	Access Service Request Enable Command.	?!<Enable Flags - (0 -255)>	Yes
	[:]STATUS[<channel>]:CLEar	Clears all the Status Data Structures.		

**Table A-11** Protection Commands

Function	SCPI Command	Description	Parameter and Range	Query
Enable the interlock functionality.	[:]SENSE[<channel>]:PROTEction:INTerlock[:STATE]	Control the Enable/Disable state of the Interlock System.	?!ONIOFF	Yes

**Table A-12** Auto Sequence Commands

Function	SCPI Command	Description	Parameter and Range	Query
Delete all sequences.	[:]PROGram[<channel>]:DELEte:ALL	Erases the sequence currently in memory.		N/A
Change Auto Sequence operating state.	[:]PROGram[<channel>]:STATe	Access to the run state of the Sequence.	?!RUNISTOPIPAUSE	Yes
Program selected sequence end action.	[:]PROGram[<channel>]:REPeaT	Sets the number of times to repeat the sequence.	?!<Repeat count (1-65534)>INFINITY	Yes

**Table A-12** Auto Sequence Commandas (Continued)

Function	SCPI Command	Description	Parameter and Range	Query
Begin Recording Auto Sequence Program	[:]PROGrama[<channel>][:RECOrd]:START	Start recording new sequence (overwrites old sequence).		N/A
Stop Recording Auto Sequence Program	[:]PROGrama[<channel>][:RECOrd]:STOP	Stop recording the auto sequence program. (Sequence ready to run.)		N/A
Set the Program Command Execution Delay Time	[:]PROGrama[<channel>][:STEP]:DWELl	Sets the amount of time to delay between commands in a Sequence.	?[<Dwell time in seconds>	Yes
Read the current contents of the Autosequence programming buffer.	[:]PROGrama[<channel>]:READback?	Read the current contents of the Autosequence programming buffer.	?	Yes



# B

## **Error Messages**

Appendix B, Error Messages, provides information on the error messages which may appear. Errors are placed in a queue as they are detected.

## Error Messages

Errors are placed in a queue as they are detected. The queue works on a first in, first out (FIFO) basis. If the queue overflows, the last error in the queue is replaced with error -350, "Queue Overflow". When all errors have been read from the queue, further error queries return 0, "No error".

The error queue is cleared when any of the following occur (IEEE 488.2, section 11.4.3.4):

- Upon receipt of a \*CLS command
- Upon reading the last item from the queue

## Command Error List

An error in the range [-199, -100] indicates that an IEEE 488.2 syntax error has been detected by the instrument's parser. The occurrence of any error in this class causes the command error bit (bit 5) in the Event Status Register to be set.

**Table B-1** Command Error List

Error Code	Error Message Description
-100	Command error This is the generic syntax error
-102	Syntax Error An unrecognized command or data type was encountered; for example, a string was received when the device does not accept strings.
-108	Parameter not Allowed More parameters were received than expected for the header; for example, the *SRE common command only accepts one parameter, so receiving *SRE 0,1 is not allowed.
-109	Missing Parameter Fewer parameters were received than required for the header; for example, the *SAV common command requires one parameter, so receiving *SAV is not allowed.
-110	Command header error An error was detected in the header.
-113	Undefined header The header is syntactically correct, but it is undefined for this specific device; for example, *XYZ is not defined for any device.
-121	Invalid character in number An invalid character for the data type being parsed was encountered; for example, an alpha in a decimal numeric or a "9" in octal data.
-140	Character data error This error is generated when parsing a character data element.
-150	String data error This error is generated when parsing a string data element fails.
-151	Invalid string data A string data element was expected, but was invalid for some reason (see <i>IEEE 488.2, 7.7.5.2</i> ); for example, an END message was received before the terminal quote character.

**B**

## Execution Error List

An error in the range [-299, -200] indicates that an error has been detected by the instrument's execution control block. The occurrence of any error in the class causes the execution error bit (bit 4) in the Event Status Register to be set.

Execution errors are reported by the device after rounding and expression evaluation operations have taken place.

**Table B-2** Execution Error List

Error Code	Error Message Description
-200	Execution Error This is the generic syntax error for devices that cannot detect more specific errors. This code indicates only that an Execution Error as defined in <i>IEEE 488.2</i> , 11.5.1.1.5 has occurred.
-203	Command protected Indicates that a legal password-protected program command or query could not be executed because the command was disabled. Check the calibration state.
-220	Parameter error Indicates that a program data element related error has occurred
-221	<p>Setting conflict Indicates that a legal program data element was parsed, but could not be executed due to the current power supply state.</p> <p>The following list is not exhaustive but does cover some of the more common conditions that may contribute to this error:</p> <ul style="list-style-type: none"> <li>• OVP/UVS Set Points —The OVP and UVS limit the setting of the voltage set point so that you cannot accidentally trigger these alarms by changing the set point outside of their range. Conversely, setting the OVP set point to be less than the voltage set point will also trigger this error.</li> <li>• Changing the Set Point while in APG mode —The user will be unable to change the set point while APG is being used to control that parameter: voltage or current.</li> <li>• Autosequence Programming —Various conflicts can occur while using Autosequence programming; for example, using the trigger command while the program is running will result in this error.</li> <li>• Calibration mode —When in calibration mode, certain settings will cause an error.</li> </ul>

**Table B-2** Execution Error List

<b>Error Code</b>	<b>Error Message Description</b>
-222	Data out of range Indicates that a legal program data element was parsed but could not be executed because the interpreted value was outside the legal range as defined by the device (see <i>IEEE 488.2</i> , 11.5.1.1.5)
-224	Illegal parameter value Used where the exact value, from a list of possible values, was expected.
-291	Out of memory Used when the Autosequence programming buffer is full.

**B**

## Device-Specific Error List

An error in the range [-399, 300] or [1, 32767] indicates that the instrument has detected an error which is not a command error, a query error, or an execution error; some device operations did not properly complete, possibly due to an abnormal hardware or firmware condition. These codes are also used for self-test response errors. The occurrence of any error in the class causes the device-specific error bit (bit 3) in the Event Status Register to be set.

**Table B-3** Device-Specific Error List

<b>Error Code</b>	<b>Error Message Description</b>
-300	Device-specific error. Indicates that the power supply could not complete the operation due to some condition of the power supply.
-313	Calibration Memory Lost
-314	Save/Recall Memory Lost
-315	Configuration Memory Lost
-350	Queue Overflow A specific code entered into the queue in lieu of the code that caused the error. This code indicates that there is no room in the queue and an error occurred but was not recorded.
-360	Communication error This is the generic communication error for devices.
-363	Input buffer overrun Software or hardware input buffer on serial port overflows with data caused by improper or nonexistent pacing.

**Table B-3** Device-Specific Error List

<b>Error Code</b>	<b>Error Message Description</b>
-365	Time out error This is a generic device-dependent error.

## Query Error List

An error number in the range [-499, -400] indicates that the output queue control of the instrument has detected a problem with the message exchange protocol described in IEEE 488.2, chapter 6. The occurrence of any error in this class causes the query error bit (bit 2) in the Event Status Register to be set.

**Table B-4** Query Error List

<b>Error Code</b>	<b>Error Message Description</b>
-400	This is the generic query error for the power supply, used only when the other types of errors do not apply.

# C

## Specifications

Appendix C, Specifications, provides the product specifications for the XG and XTR Family 850W, 1500W and 1700W Programmable DC Power Supplies.

- These specifications are represented over the full operating temperature range.
- Nominal line input voltage should be assumed unless otherwise stated.
- All sense lines are configured for local operation by default.
- Except where otherwise noted, specifications apply to single unit operation only.
- Specifications are subject to change without notice.

# Electrical Specifications for XG/XTR Family

**Table C-1** XG/XTR 850 Watt Electrical Specifications for 6 V to 600 V Models

Models	6-110	8-100	12-70	20-42	33-25	40-21	60-14	80-10.5	100-8.5	150-5.6	300-2.8	600-1.4
Output Ratings:												
Output Voltage <sup>1</sup>	6 V	8 V	12 V	20 V	33 V	40 V	60 V	80 V	100 V	150 V	300 V	600 V
Output Current <sup>2</sup>	110 A	100 A	70 A	42 A	25 A	21 A	14 A	10.5 A	8.5 A	5.6 A	2.8 A	1.4 A
Output Power <sup>3</sup>	670 W	810 W	850 W	850 W	835 W	850 W	850 W	850 W	860 W	850 W	850 W	850 W
Line Regulation:												
Voltage <sup>4</sup> (0.005% of rated output voltage +2 mV)	2.3 mV	2.4 mV	2.6 mV	3.0 mV	3.7 mV	4 mV	5 mV	6 mV	7 mV	9.5 mV	17 mV	32 mV
Current <sup>5</sup> (0.01% of rated output current +2 mA)	13 mA	12 mA	9 mA	6.2 mA	4.5 mA	4.1 mA	3.4 mA	3.1 mA	2.9 mA	2.6 mA	2.3 mA	2.1 mA
Load Regulation												
Voltage <sup>6</sup> (0.005% of rated output voltage + 2 mV)	2.3 mV	2.4 mV	2.6 mV	3.0 mV	3.7 mV	4 mV	5 mV	6 mV	7 mV	9.5 mV	17 mV	32 mV
Current <sup>7</sup> (0.02% of rated output current +5 mA)	27 mA	25 mA	19 mA	13.4 mA	10 mA	9.2 mA	7.8 mA	7.1 mA	6.7 mA	6.1 mA	5.6 mA	5.3 mA
Output Ripple (rms, 300 kHz):												
Voltage	8 mV	8 mV	8 mV	8 mV	8 mV	8 mV	8 mV	8 mV	8 mV	10 mV	25 mV	50 mV
Current <sup>8</sup>	200 mA	180 mA	120 mA	75 mA	60 mA	45 mA	35 mA	25 mA	20 mA	16 mA	10 mA	6 mA
Output Noise (p-p, 20 MHz): Voltage	50 mV	50 mV	50 mV	50 mV	50 mV	50 mV	50 mV	80 mV	80 mV	100 mV	150 mV	250 mV
Maximum Recommended Remote Sense Line Drop Compensation per Line <sup>9</sup>	1 V	1 V	1 V	1.5 V	2 V	2 V	3 V	5 V	5 V	5 V	5 V	5 V
Up-prog. Response Time, 0~Vmax <sup>10</sup>	60 ms	60 ms	60 ms	60 ms	60 ms	60 ms	60 ms	100 ms	100 ms	100 ms	150 ms	250 ms
Down-prog. Response Time: Full Load	50 ms	50 ms	50 ms	50 ms	50 ms	50 ms	50 ms	80 ms	100 ms	150 ms	150 ms	250 ms
Down-prog. Response Time: No Load	300 ms	400 ms	500 ms	600 ms	700 ms	800 ms	900 ms	1000 ms	1200 ms	1800 ms	2200 ms	3500 ms
Over-Voltage Trip Point	0.5–7.5 V	0.5–10 V	1–15 V	1–24 V	2–39 V	2–44 V	3–66 V	3–95 V	3–125 V	3–180 V	5–330 V	5–660 V



**Table C-1** XG/XTR 850 Watt Electrical Specifications for 6 V to 600 V Models

Models	6-110	8-100	12-70	20-42	33-25	40-21	60-14	80-10.5	100-8.5	150-5.6	300-2.8	600-1.4
Efficiency <sup>11</sup>	75/77%	77/80%	79.5/ 82.5%	82/85%	83/86%	83/87%	83/87%	83/87%	83/87%	83/87%	83/87%	83/87%

1. Maximum output voltage is guaranteed to be  $\leq 0.1\%$  of the rated voltage at zero output setting, using the front panel or digital remote programming modes.
  2. Maximum output current is guaranteed to be  $\leq 0.2\%$  of the rated current at zero output setting, using the front panel or digital remote programming modes, and when measured with rated load resistance.
  3. Total output power is also based on AUX1 Output Voltage (5 V) and AUX1 Output Current (0.5 A) and AUX2 Output Voltage (15 V) and AUX2 Output Current (0.5 A).
  4. From 85–132 Vac or 170–265 Vac, constant load.
  5. From 85–132 Vac or 170–265 Vac, constant load.
  6. From no load to full load, constant input voltage.
  7. For load voltage change, equal to the unit voltage rating, constant input voltage.
  8. For 6 V models the current ripple is measured at 2–6 V output voltage and full output current. For all other models, the current ripple is measured at 10–100% output voltage and full output current.
  9. When using remote sense, the total of the load voltage and the load line drops must not exceed the rated output of the power supply. For example, for an XG/XTR 6-110 in an application with 1 V of load line loss (0.5 V/Line), the maximum available load voltage would be 6–1= 5 V. Note: The unit may operate at higher output voltages than this, but there is no guarantee that the power supply will meet performance specifications. Ultimately, the upper limit of the output voltage will be determined by internal circuitry of the power supply (non-adjustable.)
  10. With rated, resistive load.
  11. At 100/200 Vac input voltage and maximum output power.
- Applies to all footnotes: Programming and Readback: RS-232, RS-485, USB built in. GPIB, Ethernet optional.  
Specifications are guaranteed from 1% to 100% of the rated output voltage, current, and power.

## AC Line Input Specifications for XG/XTR 850 Watt

The input to the power supply requires the following input specifications.

Rated AC Input Voltage/Frequency	100–240 Vac, 47–63 Hz
Operational AC Input Voltage/Frequency	85–265 Vac continuous, single phase, 47–63 Hz
Input Current (at 100/200 Vac)	11.5/6 A
Inrush Current (100/200 Vac)	Less than 25 A
Power Factor Correction	0.99@100/200 Vac, rated output power

# Electrical Specifications for XG/XTR Family

**Table C-2** XG/XTR 1500 Watt Electrical Specifications for 6 V to 600 V Models

Models	6-220	8-187.5	12.5-120	20-76	30-50	40-38	60-25	80-19	100-15	150-10	300-5	600-2.6
Output Ratings:												
Output Voltage <sup>1</sup>	6 V	8 V	12.5 V	20 V	30 V	40 V	60 V	80 V	100 V	150 V	300 V	600 V
Output Current <sup>2</sup>	220 A	187.5 A	120 A	76 A	50 A	38 A	25 A	19 A	15 A	10 A	5 A	2.6 A
Output Power <sup>3</sup>	1320 W	1500 W	1500 W	1520 W	1500 W	1520 W	1500 W	1520 W	1500 W	1500 W	1500 W	1560 W
Line Regulation:												
Voltage <sup>4</sup> (0.005% of rated output voltage +2 mV)	2.3 mV	2.4 mV	2.62 mV	3.0 mV	3.5 mV	4 mV	5 mV	6 mV	7 mV	9.5 mV	17 mV	32 mV
Current <sup>5</sup> (0.01% of rated output current +2 mA)	24mA	20.7mA	14mA	9.6mA	7mA	5.8mA	4.5mA	3.9mA	3.5mA	3mA	2.5mA	2.26A
Load Regulation												
Voltage <sup>6</sup> (0.005% of rated output voltage + 2 mV)	2.3 mV	2.4 mV	2.62 mV	3.0 mV	3.5 mV	4 mV	5 mV	6 mV	7 mV	9.5 mV	17 mV	32 mV
Current <sup>7</sup> (0.02% of rated output current +5 mA)	49 mA	42.5 mA	29 mA	20.2 mA	15 mA	12.6 mA	10 mA	8.8 mA	8 mA	7 mA	6 mA	5.5 mA
Output Ripple (rms, 300 kHz):												
Voltage	8 mV	8 mV	8 mV	8 mV	8 mV	8 mV	8 mV	8 mV	8 mV	10 mV	25 mV	50 mV
Current <sup>8</sup>	400mA	319mA	206mA	136mA	120mA	81mA	63mA	45mA	35mA	29mA	18mA	11mA
Output Noise (p-p, 20 MHz): Voltage	50 mV	50 mV	50 mV	50 mV	50 mV	50 mV	50 mV	80 mV	80 mV	100 mV	150 mV	250 mV
Maximum Recommended Remote Sense Line Drop Compensation per Line <sup>9</sup>	1 V	1 V	1 V	1.5 V	2 V	2 V	3 V	5 V	5 V	5 V	5 V	5 V
Up-prog. Response Time, 0~Vmax <sup>10</sup>	60 ms	60 ms	60 ms	60 ms	60 ms	60 ms	60 ms	100 ms	100 ms	100 ms	150 ms	250 ms
Down-prog. Response Time: Full Load	50 ms	50 ms	50 ms	50 ms	50 ms	50 ms	50 ms	80 ms	100 ms	150 ms	150 ms	250 ms
Down-prog. Response Time: No Load	300 ms	400 ms	500 ms	600 ms	700 ms	800 ms	900 ms	1000 ms	1200 ms	1800 ms	2200 ms	3500 ms
Over-Voltage Trip Point	0.5–7.5 V	0.5–10 V	1–15 V	1–24 V	2–36 V	2–44 V	5–66 V	5–88 V	5–110 V	5–165 V	5–330 V	5–660 V

**Table C-2** XG/XTR 1500 Watt Electrical Specifications for 6 V to 600 V Models

Models	6-220	8-187.5	12.5-120	20-76	30-50	40-38	60-25	80-19	100-15	150-10	300-5	600-2.6
Efficiency <sup>11</sup>	76/78%	77/79%	81/ 84%	82/85%	83/86%	84/88%	84/88%	84/88%	84/88%	84/88%	84/88%	84/88%

1. Maximum output voltage is guaranteed to be  $\leq 0.1\%$  of the rated voltage at zero output setting, using the front panel or digital remote programming modes.
  2. Maximum output current is guaranteed to be  $\leq 0.2\%$  of the rated current at zero output setting, using the front panel or digital remote programming modes, and when measured with rated load resistance.
  3. Total output power doesn't include AUX1 Output Voltage (5 V) and AUX1 Output Current (0.5 A) and AUX2 Output Voltage (15 V) and AUX2 Output Current (0.5 A).
  4. From 90–132 Vac or 170–265 Vac, constant load.
  5. From 90–132 Vac or 170–265 Vac, constant load.
  6. From no load to full load, constant input voltage.
  7. For load voltage change, equal to the unit voltage rating, constant input voltage.
  8. For 6 V models the current ripple is measured at 2–6 V output voltage and full output current. For all other models, the current ripple is measured at 10–100% output voltage and full output current.
  9. When using remote sense, the total of the load voltage and the load line drops must not exceed the rated output of the power supply. For example, for an XG 6-220 in an application with 1 V of load line loss (0.5 V/Line), the maximum available load voltage would be  $6-1=5$  V. Note: The unit may operate at higher output voltages than this, but there is no guarantee that the power supply will meet performance specifications. Ultimately, the upper limit of the output voltage will be determined by internal circuitry of the power supply (non-adjustable).
  10. With rated, resistive load.
  11. At 100/200 Vac input voltage and maximum output power.
- Applies to all footnotes: Programming and Readback: RS-232, RS-485, USB built in. GPIB, Ethernet optional.  
Specifications are guaranteed from 1% to 100% of the rated output voltage, current, and power.

## AC Line Input Specifications for XG/XTR 1500 Watt

The input to the power supply requires the following input specifications.

Rated AC Input Voltage/Frequency	100–240 Vac, 47–63 Hz
Operational AC Input Voltage/Frequency	85–265 Vac continuous, single phase, 47–63 Hz, single phase
Input Current (at 100/200 Vac)	23/12 A
Inrush Current (100/200 Vac)	Less than 50 A
Power Factor Correction	0.99@100/200 Vac, rated output power

## Electrical Specifications for XG/XTR Family

**Table C-3** XG 1700 Watt Electrical Specifications for 6 V to 600 V Models

Models	6-220	8-200	12-140	20-84	33-50	40-42	60-28	80-21	100-17	150-11.2	300-5.6	600-2.8
Output Ratings:												
Output Voltage <sup>1</sup>	6 V	8 V	12 V	20 V	33 V	40 V	60 V	80 V	100 V	150 V	300 V	600 V
Output Current <sup>2</sup>	220 A	200 A	140 A	84 A	50 A	42 A	28 A	21 A	17 A	11.2 A	5.6 A	2.8 A
Output Power <sup>3</sup>	1330 W	1610 W	1690 W	1690 W	1660 W	1690 W	1690 W	1690 W	1710 W	1690W	1690 W	1690 W
Line Regulation:												
Voltage <sup>4</sup> (0.005% of rated output voltage +2 mV)	2.3 mV	2.4 mV	2.6 mV	3.0 mV	3.7 mV	4 mV	5 mV	6 mV	7 mV	9.5 mV	17 mV	32 mV
Current <sup>5</sup> (0.01% of rated output current +2 mA)	24 mA	22 mA	16 mA	10.4 mA	7 mA	6.2 mA	4.8 mA	4.1 mA	3.7 mA	3.12 mA	2.56 mA	2.28 mA
Load Regulation												
Voltage <sup>6</sup> (0.005% of rated output voltage + 2 mV)	2.3 mV	2.4 mV	2.6 mV	3.0 mV	3.7 mV	4 mV	5 mV	6 mV	7 mV	9.5 mV	17 mV	32 mV
Current <sup>7</sup> (0.02% of rated output current +5 mA)	49 mA	45 mA	33 mA	22 mA	15 mA	13 mA	10.6 mA	9.21 mA	8.4 mA	7.2 mA	6.1 mA	5.6 mA
Output Ripple (rms, 300 kHz):												
Voltage	8 mV	8 mV	8 mV	8 mV	8 mV	8 mV	8 mV	8 mV	8 mV	10 mV	25 mV	50 mV
Current <sup>8</sup>	400 mA	340 mA	240 mA	150 mA	120 mA	90 mA	70mA	50 mA	40 mA	32 mA	20 mA	12 mA
Output Noise (p-p, 20 MHz): Voltage	50 mV	50 mV	50 mV	50 mV	50 mV	50 mV	50 mV	80 mV	80 mV	100 mV	150 mV	250 mV
Maximum Recommended Remote Sense Line Drop Compensation per Line <sup>9</sup>	1 V	1 V	1 V	1.5 V	2 V	2 V	3 V	5 V	5 V	5 V	5 V	5 V
Up-prog. Response Time, 0~Vmax <sup>10</sup>	60 ms	60 ms	60 ms	60 ms	60 ms	60 ms	60 ms	100 ms	100 ms	100 ms	150 ms	250 ms
Down-prog. Response Time: Full Load	50 ms	50 ms	50 ms	50 ms	50 ms	50 ms	50 ms	80 ms	100 ms	150 ms	150 ms	250 ms
Down-prog. Response Time: No Load	300 ms	400 ms	500 ms	600 ms	700 ms	800 ms	900 ms	1000 ms	1200 ms	1800 ms	2200 ms	3500 ms
Over-Voltage Trip Point	0.5–7.5 V	0.5–10 V	1–15 V	1–24 V	2–39 V	2–44 V	3–66 V	3–95 V	3–125 V	3–180 V	5–330 V	5–660 V

**Table C-3** XG/XTR 1700 Watt Electrical Specifications for 6 V to 600 V Models

Models	6-220	8-200	12-140	20-84	33-50	40-42	60-28	80-21	100-17	150-11.2	300-5.6	600-2.8
Efficiency <sup>11</sup>	76/78%	77/79%	81/ 84%	82/85%	83/86%	84/88%	84/88%	84/88%	84/88%	84/88%	84/88%	84/88%

1. Maximum output voltage is guaranteed to be  $\leq 0.1\%$  of the rated voltage at zero output setting, using the front panel or digital remote programming modes.
  2. Maximum output current is guaranteed to be  $\leq 0.2\%$  of the rated current at zero output setting, using the front panel or digital remote programming modes, and when measured with rated load resistance.
  3. Total output power is also based on AUX1 Output Voltage (5 V) and AUX1 Output Current (0.5 A) and AUX2 Output Voltage (15 V) and AUX2 Output Current (0.5 A).
  4. From 90–132 Vac or 170–265 Vac, constant load.
  5. From 90–132 Vac or 170–265 Vac, constant load.
  6. From no load to full load, constant input voltage.
  7. For load voltage change, equal to the unit voltage rating, constant input voltage.
  8. For 6 V models the current ripple is measured at 2–6 V output voltage and full output current. For all other models, the current ripple is measured at 10–100% output voltage and full output current.
  9. When using remote sense, the total of the load voltage and the load line drops must not exceed the rated output of the power supply. For example, for an XG/XTR 6-220 in an application with 1 V of load line loss (0.5 V/Line), the maximum available load voltage would be 6–1= 5 V. Note: The unit may operate at higher output voltages than this, but there is no guarantee that the power supply will meet performance specifications. Ultimately, the upper limit of the output voltage will be determined by internal circuitry of the power supply (non-adjustable.)
  10. With rated, resistive load.
  11. At 100/200 Vac input voltage and maximum output power.
- Applies to all footnotes: Programming and Readback: RS-232, RS-485, USB built in. GPIB, Ethernet optional.  
Specifications are guaranteed from 1% to 100% of the rated output voltage, current, and power.

## AC Line Input Specifications for XG/XTR 1700 Watt

The input to the power supply requires the following input specifications.

Rated AC Input Voltage/Frequency	100–240 Vac, 47–63 Hz
Operational AC Input Voltage/Frequency	85–265 Vac continuous, single phase, 47–63 Hz, single phase
Input Current (at 100/200 Vac)	23/12 A
Inrush Current (100/200 Vac)	Less than 50 A
Power Factor Correction	0.99@100/200 Vac, rated output power

# Remote Operation

**Table C-4 Remote Operation**

Programming Mode	APG	ISOL	Digital
Voltage and Current Output Voltage Programming	0–100%. Voltage control range is 0.0 to 2.0-10.0V in 0.1V increments.		
Voltage and Current Output Resistive Programming	0-100%. Resistive control range is 0.0 to 2.0 - 10.0K in 0.1K increments.		
Output Voltage and Current Monitor	0-100%. Output voltage monitor range is 0.0 to 2.0 - 10.0V in 0.1V increments.		
Voltage Programming Accuracy <sup>1</sup>	± 0.5% of rated output voltage, max. (0 to 4.0V / 4K Ohm range) ± 0.5% of rated output voltage, typical in other ranges		±0.1% of rated output voltage
Current Programming Accuracy <sup>1</sup>	± 1.0% of rated output current, max. (0 to 4.0V / 4K Ohm range) ± 1.0% of rated output current, typical in other ranges		±0.2% of rated output current
Voltage Readback Accuracy	± 1% of range full scale		±0.1% of rated output voltage
Current Readback Accuracy	± 1% of range full scale		±0.2% of rated output current
Isolation (Prog and Readback Lines)	With respect to chassis potential: 500 V	With respect to: chassis potential: 600 V . negative or positive main output: 1500 V .	
Voltage and Current Programming Resolution			0.012% of full scale
Voltage and Current Readback Resolution			
Parallel Operation	Up to 4 units in master/slave mode	Up to 4 units in master/slave mode	Up to 4 units in master/slave mode
Series Operation	Up to 2 units (with external diodes)		
Constant Voltage (CV)/Constant Current (CC) Indicator	CV: TTL High (4–5 V) CC: TTL Low (0–0.6 V)		
Shutdown Control <sup>2</sup>		Logic low 0.0 - 1.4V Logic high 2.0 - 15V Dry contact compatible	
OUTPUT ENABLE Auxiliary Control		TTL level or dry contact compatible	
Power Supply Status Signal		TTL high: OK (4–5 V) TTL low: fail (0–0.6 V)	
Interlock Enable/Disable		Dry contact. Open/Short: On or Off, programmable	

1. Typical APG or isolated APG accuracy can be improved to max accuracy by user calibration at the specific range selected.
2. The shutdown input has user selectable negative logic operation via front panel or remote digital input/output.

# Common Specifications for All Models

## Output Performance Specifications

Aux output <sup>1</sup>	+5V: +0.4V, – 0.5V at 0.4A +15V: +1.2V, – 1.4V at 0.4A
Temperature Coefficient	100 PPM/° C from rated output voltage, after a 30-minute warm-up
Drift (8 hours)	0.05% of rated output (over an 8 hour interval with constant line, load and temperature, after a 30-minute warm-up)
Hold-up Time	Typical 20 ms at any rated input line.
Transient Response Time <sup>2</sup>	Less than 1 ms for 6 V to 60 V models. Less than 2 ms for 80 V to 600 V models
Meter Accuracy	0.5% of actual output voltage or current ± 1 count
Isolation	
AC Input to Output	1350 Vac
AC Input to Chassis	1350 Vac
Output to Chassis <sup>3</sup>	500 Va c

1. Current: 0.51A minimum guaranteed, 0.72A typically available. Overcurrent protection (each output) is automatic, non-latching. When OCP is tripped the aux voltage folds back and will recover to nominal condition when the over current condition is removed (typ. < 0.2A).

To protect external circuits attached to the aux outputs it is recommended that customers use an appropriately rated fuse in series with the aux outputs being used.

2. Time for the output voltage to recover within 0.5% at its rated output for a load change 10–90% of rated output current. Output set point 10–100%.

3. For floating chassis ground applications, please contact applications engineering for system design assistance.

**Environmental Specifications (Indoor use)**

Operating Temperature Range	0 °C to 50 °C, 100% load
Storage Temperature Range	-20 °C to 70 °C
Operating Humidity Range	30-90% RH (no condensation)
Storage Humidity Range	10-95% RH (no condensation)
Operating Altitude	Up to 6,500 feet (2,000 m)
Installation Category	II (IEC 1010-1)
Pollution Degree	2 (IEC 1010-1)

**Mechanical Specifications**

XG/XTR 850 Watt (WxHxD) XG/XTR 1500 Watt and 1700 Watt (WxHxD)	8.4 × 1.7 × 19.0 inch (214 × 43.6 × 483 mm) 16.8 × 1.7 × 19.0 inch (428 × 43.6 × 483 mm)
Weight XG/XTR 850 Watt XG/XTR 1500 Watt and 1700 Watt	11 lb (5kg) 20 lb (9.5 kg)
Cooling	Forced air cooling by internal fans

**Regulatory Approvals**

Safety	CSA 22.2 No. 61010-1 and UL61010-1. Marked with cCSAus, CE EN61010-1
EMC	Complies with EN61326-1 Complies with EN55022, Class A, FCC Part 15A for conducted emissions Complies with EN55022, Class A, FCC Part 15A for radiated emissions Complies with EN61000-4 series of standards for immunity



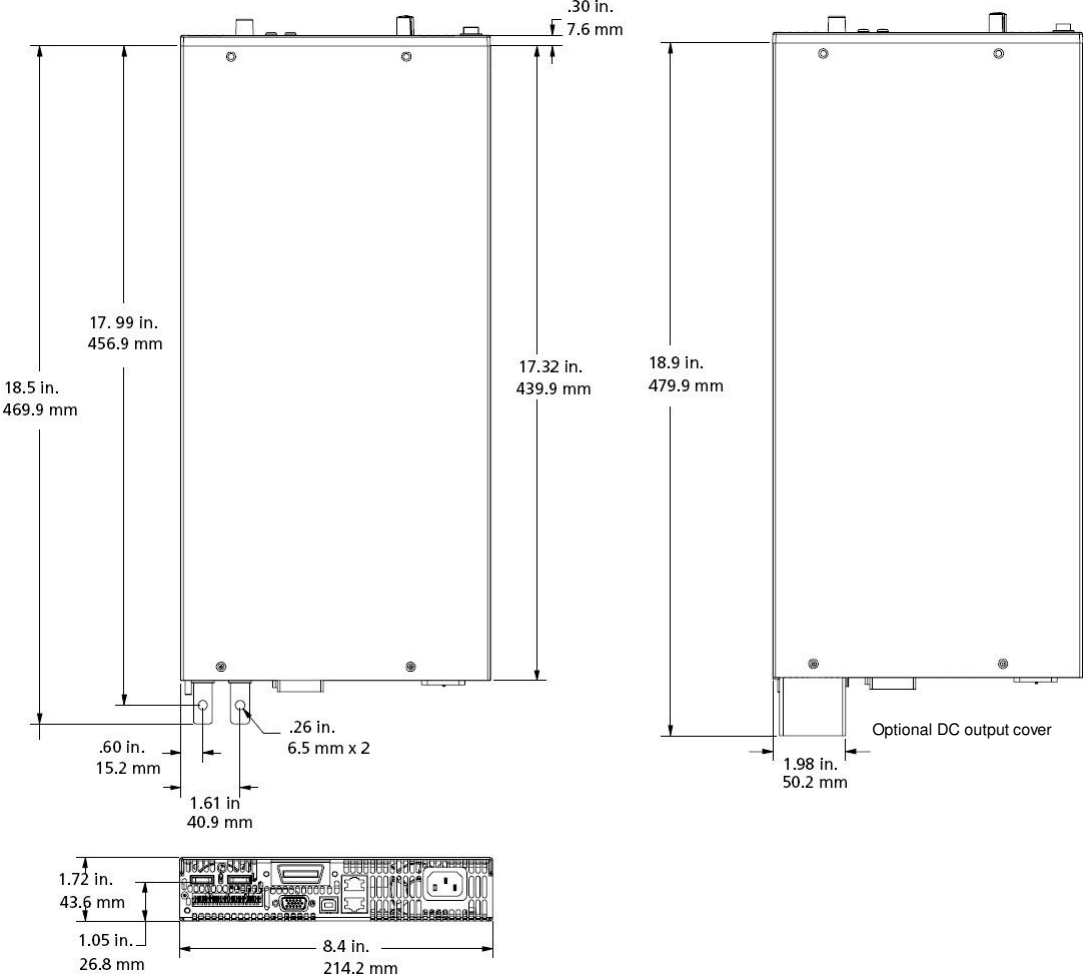
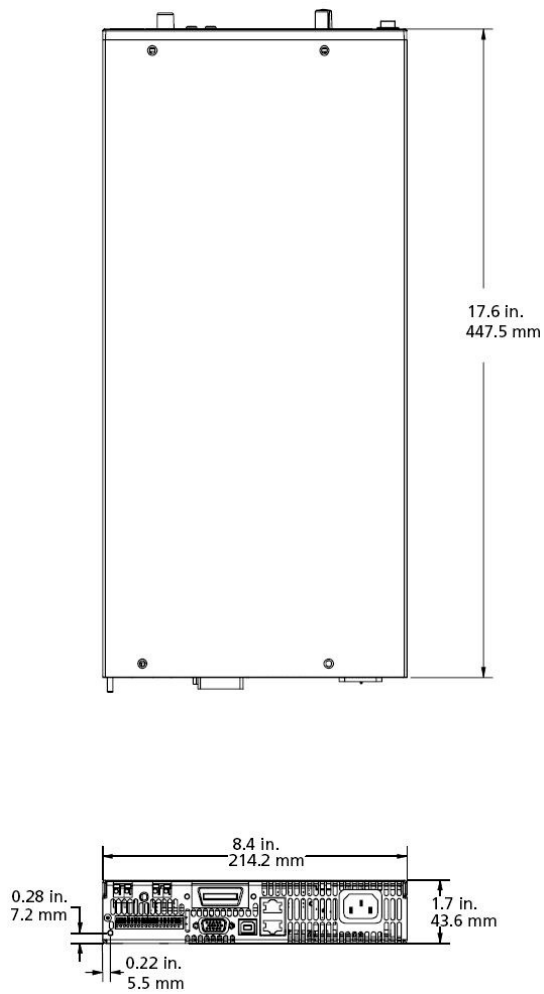


Figure C-1 XG/XTR 850 Watt Mechanical Dimensions: 6 to 40 V Models

## Specifications

---



**Figure C-2** XG/XTR 850 Watt Mechanical Dimensions: 60 V to 600 V Models

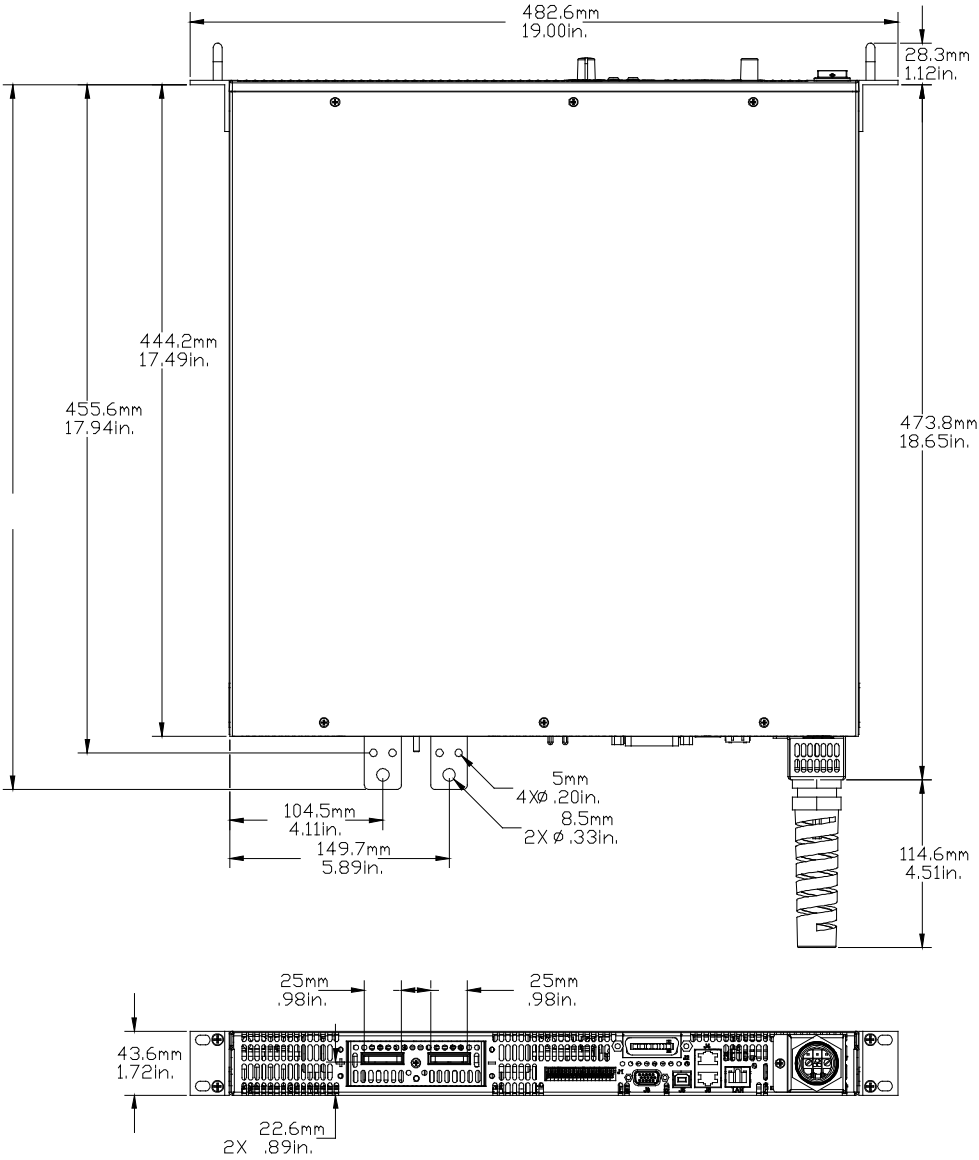
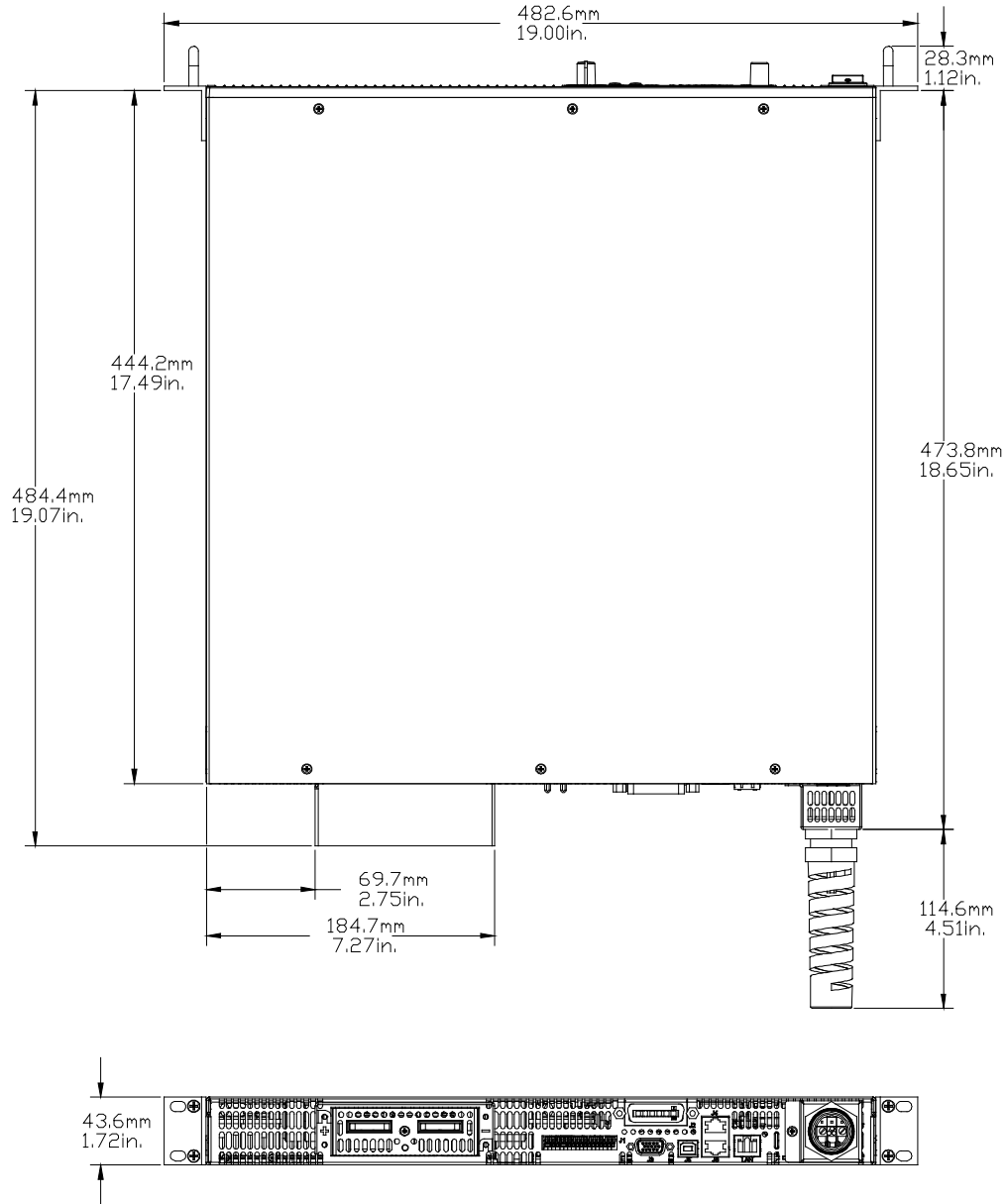


Figure C-3 XG/XTR 1700 Watt Mechanical Dimensions: 6 V to 40 V Models



**Figure C-4** XG/XTR 1700 Watt Mechanical Dimensions: 6 V to 40 V Models DC Output Cover

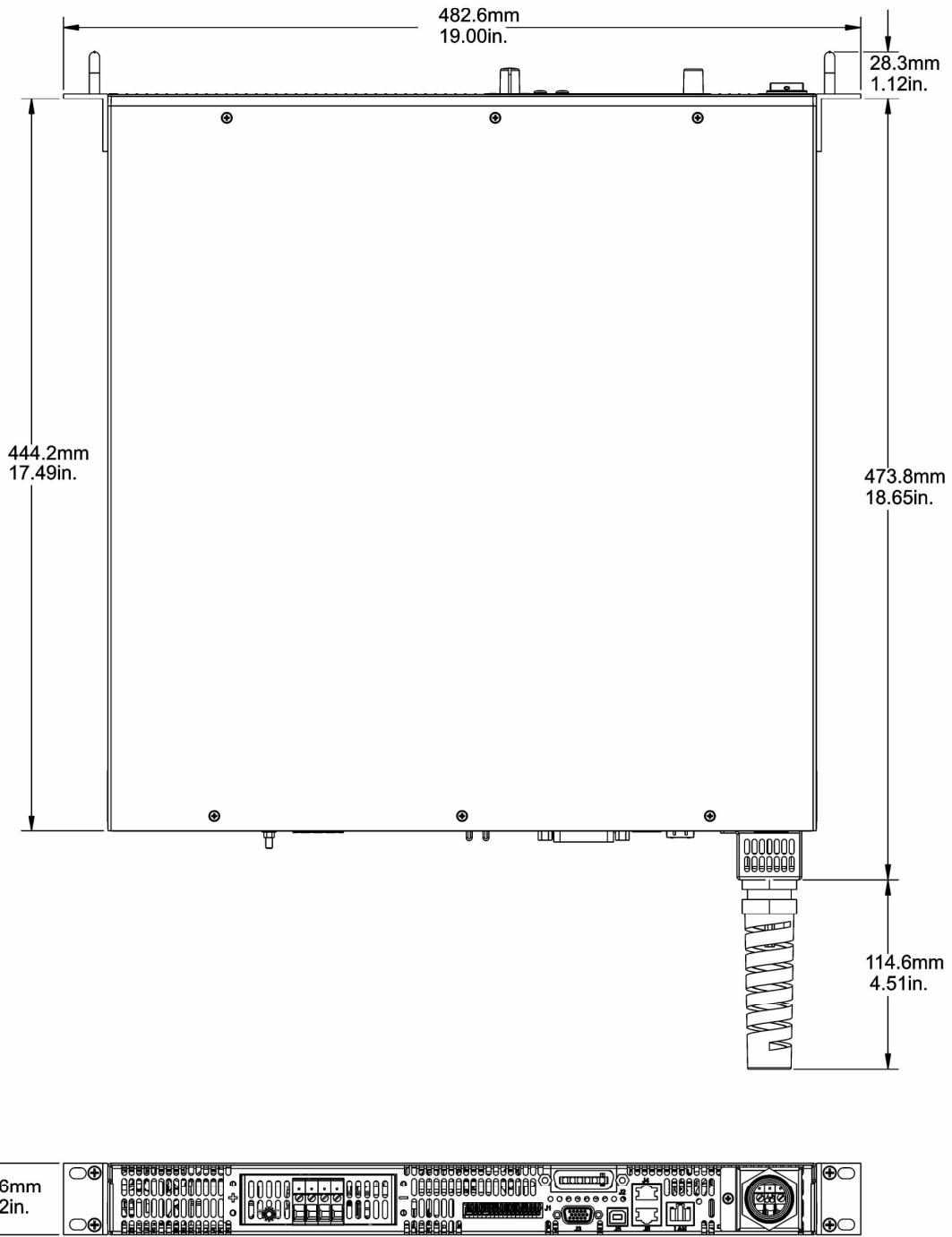
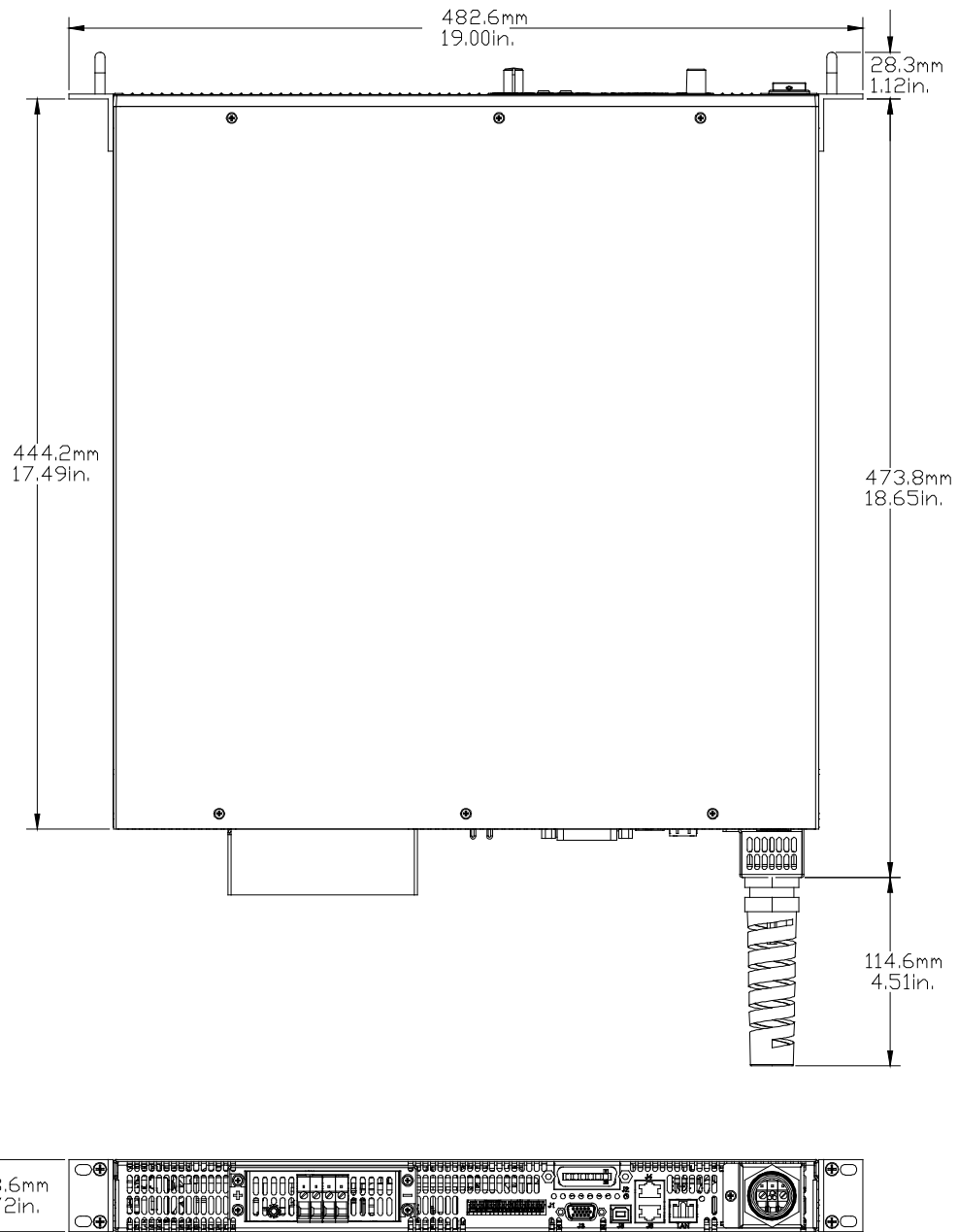


Figure C-5 XG/XTR 1700 Watt Mechanical Dimensions: 60 V to 600 V Models

# Specifications



**Figure C-6** XG/XTR 1700 Watt Mechanical Dimensions: 60 V to 600 V Models w/DC Output Cover

# D

## **Rack Mount Options and Installation Instructions**

Appendix D provides information on rack mount kit options and instructions for XG/XTR half-rack and full-rack mounting.



## Rack Mount Kit Options

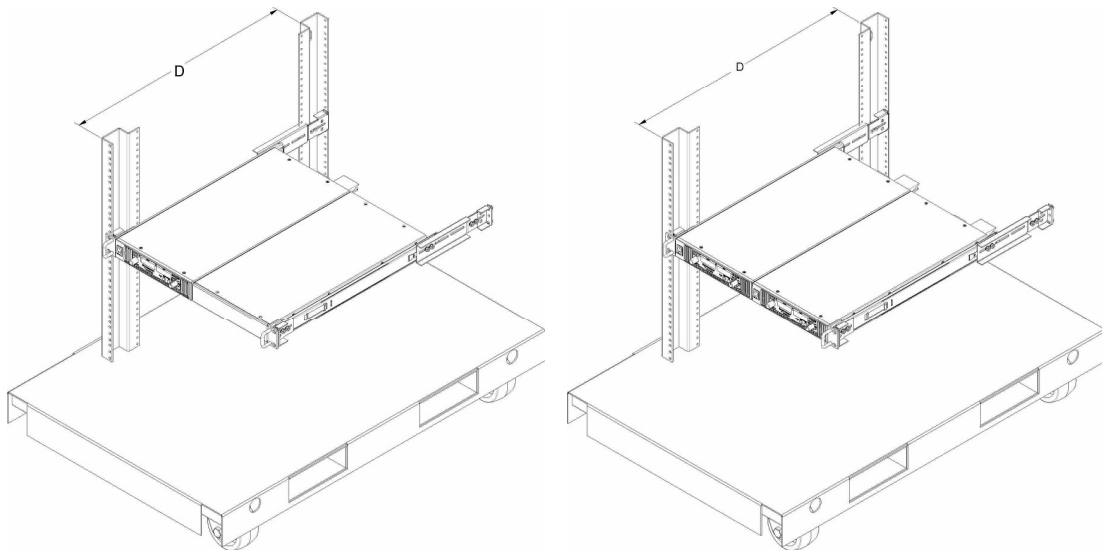
Table D-1 describes the options available for rack mounting the power supply and provides the part numbers for each option.

**Table D-1 Rack Mount Options**

Unit	Option A: Rack Mount with Rails	Option B: Rack Mount with Slides
XG Single	RM-S-XG2 (Fig D-1, left) and RM-XG2	RM-S-XG2 (Table D-2, page D-7)
XG Dual	RM-D-XG2 (Fig D-1, right) and RM-XG2	RM-D-XG2 (Table D-2, page D-7)
XTR Single	RM-S-XTR2 (Fig D-1, left) and RM-XTR2	RM-S-XTR2 (Table D-2, page D-7)
XTR Dual	RM-D-XTR2 (Fig D-1, right) and RM-XTR2	RM-D-XTR2 (Table D-2, page D-7)

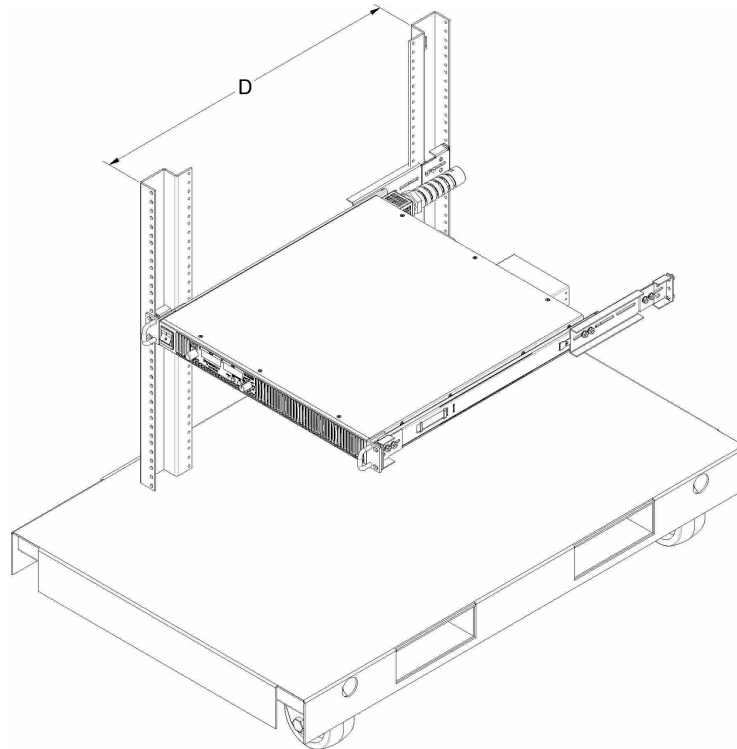
### XG/XTR Single (Half Rack) and Dual (Full Rack)

Figure shows the rack mount kit options for installing the XG/XTR into a half rack and a full rack. Note that the 850 Watt units are the only units that can be installed in either; all other units can be installed in the half rack only.



**Figure D-1 Single (left,) and Dual (right) Half Rack Mount Kit Options**





**Figure D-2 Full Rack Mount Kit Option**

## Location Requirements

Install the power supply in a location that meets the following requirements:

Condition	Description
Clean	The power supply should not be exposed to metal filings or any other form of conductive contamination.
Cool	The ambient air temperature should be between 0 °C–50 °C (32 °F–122 °F) for best performance.
Ventilated	Whether operating the power supply in a rack or on a bench, allow air to reach the ventilation inlets on the front and rear of the unit for cooling. The direction of airflow is from the front to the back of the unit. Ventilation space at the top, bottom or sides of the power supply is not required



### **WARNING: Shock hazard**

Ensure that any mounting screws do not penetrate more than 1/8 in. (3.0 mm) into the bottom and/or the back of the unit.

## Mounting Option A: 1U Rails

1U rails are to support the power supply rack mount packages. The rail is a flanged rail type and only available for a rack depth of 25 inches.

The part number to order this option is RM-XG2 for the XG family and RM-XTR2 for the XTR family.

### Tools and Materials Required

To mount and connect the power supply, you will need the following tools and materials:

- Screwdriver (Phillips head, #2)
- Standard carpenter's level
- Eight #10-24 × 1/4" (30 mm) Phillips head screws.

### Installation Procedures

To install the power supply in an equipment rack:

1. Ensure that your rack resembles the rack shown in Figure D-3, and has inner holes within the specified dimensions.
2. Find the 1U space in which you wish to install your power supply in the specific rack.
3. Place the lower plain flange of the RM-XG2/RM-XTR2 rail at the lowest point of the 1U space. If it is placed correctly, a hole on the inner flange of the vertical rack will line up to the oval mounting slot in the rail.
4. Using the carpenter's level for accuracy, install the rail using two #10-24 screws.
5. Tighten the screws to a torque of 20.5 to 22.5 in-lbs.
6. Repeat on the opposite side, using the level to ensure both rails align.
7. Slide the power supply assembly onto the rails, and against the front rails of the rack.
8. If there are four front mounting locations available, then install four #10-24 screws. Tighten the screws to a torque of 20.5 to 22.5 in-lbs. If there is only one hole available on either side, then the RM-XG2/RM-XTR2 rails are not installed correctly.

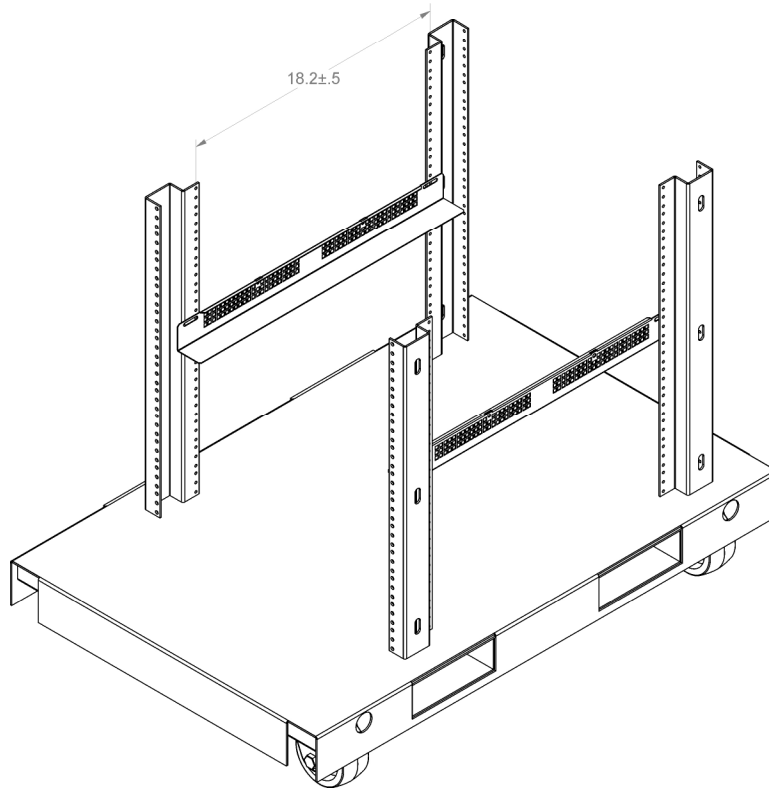


Figure D-3 RM-XG2/RM-XTR2 Rack Rails

## Mounting Option B: Manufactured Slides from Jonathan® Engineered Solutions

Jonathan Engineered Solutions offers a wide variety of manufactured slides to allow the easy installation and removal of the power supply assemblies into all rack sizes. Follow these steps to find the Jonathan product that suits your needs.

### To install a single power supply in an equipment rack:

1. Find your rack depth (D), which is the distance between the front and back flanges. See Figure D-4.

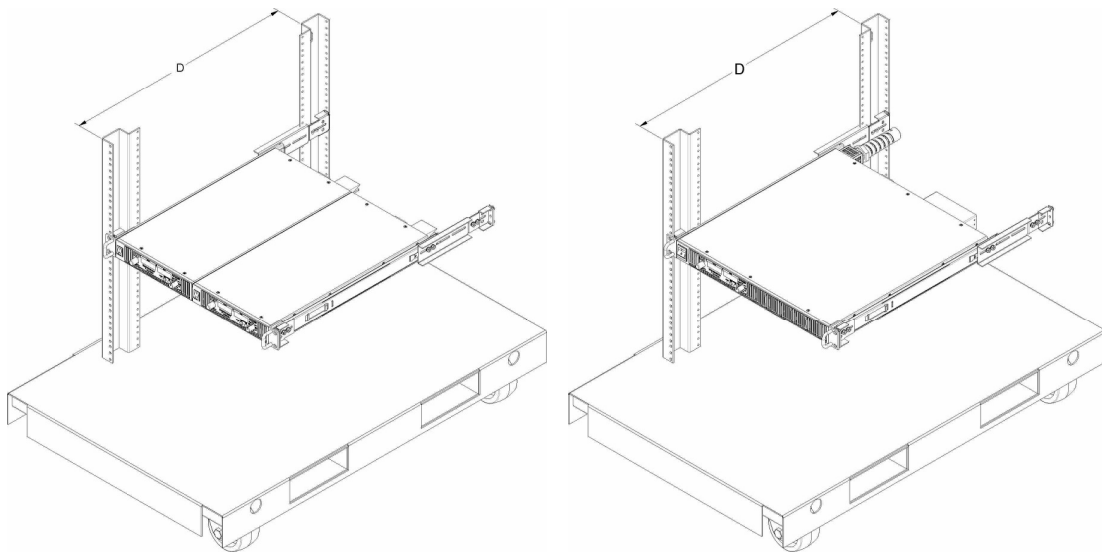


Figure D-4 Finding Rack Depth

2. Select your rail type. See Figure D-5.

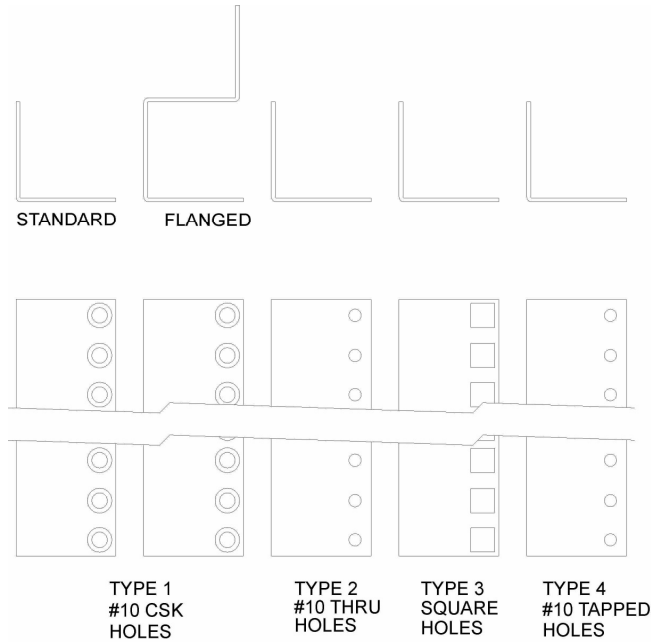


Figure D-5 Selecting a Rail Type

3. Refer to **Table D-2** to select the correct Jonathan Engineered Solutions (Jonathan) slide part number for your rack depth and rail type.

Table D-2 Part Numbers for Jonathan Manufactured Slides

Rack Depth "D" (in.)	Jonathan Slide Part Number	Bracket For Rail Types 1, 2, 3		Bracket for Rail Type 4	
		Front	Rear	Front	Rear
Less than 20	XG/XTR Chassis will not fit within cabinet (depth of unit 19.25")				
20–22.5	375QD-18	SPO-622	SPO-683-2	SPO-857	SPO-857
20–25.5	375QD-18	SPO-622	SPO-683	SPO-857	SPO-857
20–27.5	375QD-18	SPO-622	SPO-683-1	SPO-857	SPO-857
20–30	375QD-18	SPO-683	SPO-683	SPO-857	SPO-683
20–34	375QD-18	SPO-683-1	SPO-683-1	SPO-857	SPO-683-12
25.5–27.5	375QD-26	SPO-622	SPO-622	SPO-857	SPO-857
27.5–29.5	375QD-28	SPO-622	SPO-622	SPO-857	SPO-857
29.5–32.5	375QD-28	SPO-622	SPO-683-2	SPO-857	SPO-857
29.5–35.5	375QD-28	SPO-622	SPO-683	SPO-857	SPO-857
29.5–37.25	375QD-28	SPO-622	SPO-683-1	SPO-857	SPO-6832

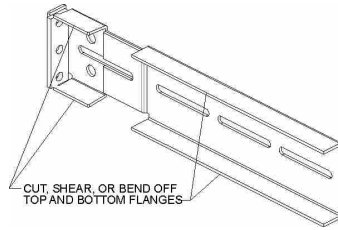


Figure D-6 Modifying Rear Bracket

4. Remove the chassis member from the slides and assemble to the chassis using M5 × 6mm pan head screw SST (6X) which are not supplied. See Figure D-7.

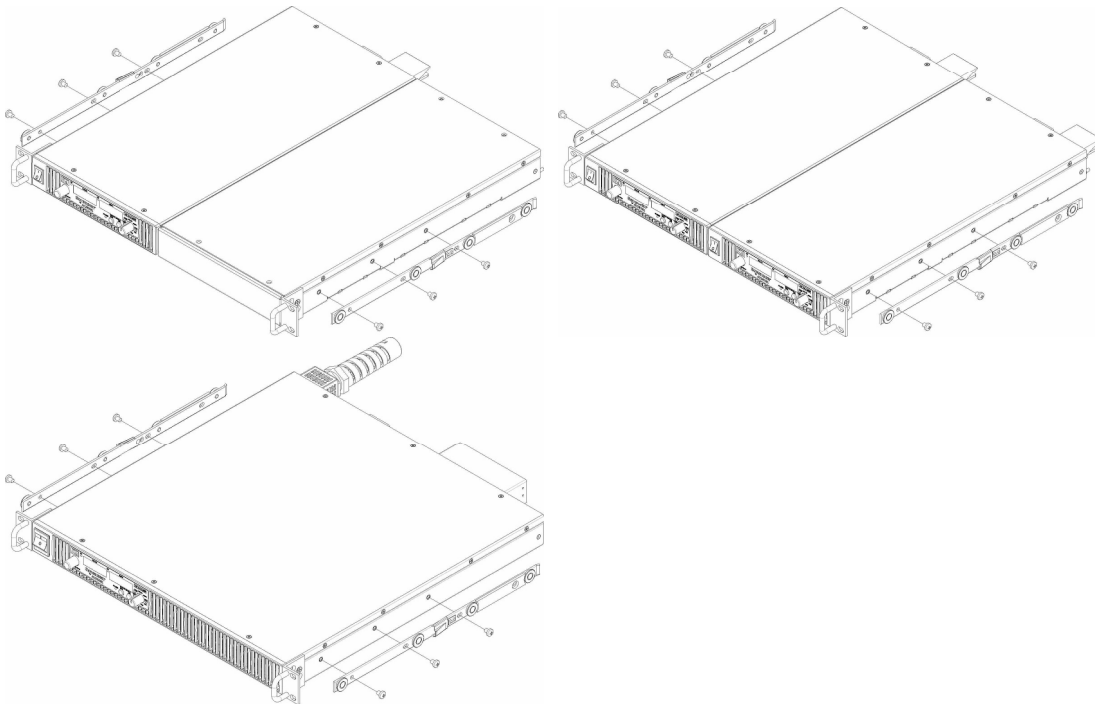


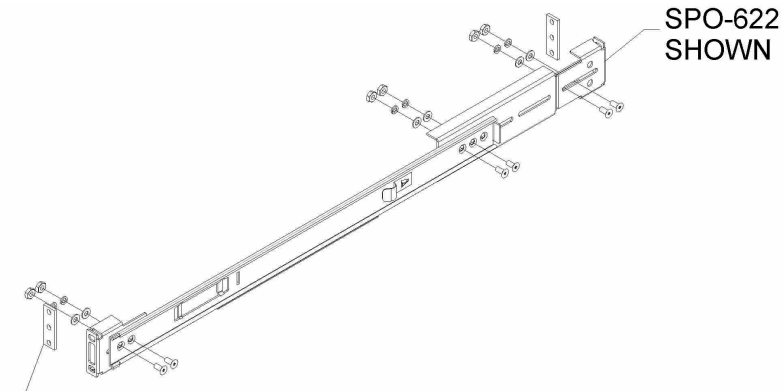
Figure D-7 Removing Chassis Member From Slides

---

**Important:** Figure 6 shows the chassis member for slide 375QD-18. The chassis member will be longer for Jonathan slide 375QD-26/28.

---

5. Attach front and rear brackets to cabinet section (see Figure D-8) using the following materials supplied with the slides:
  - (4) #8 × 0.375 Flat Head Countersunk Screws SST
  - (4) #8 Lock Washers
  - (4) #8 Regular Washers
  - (4) #8 Hex Nuts



BAR NUT, SPO-623, SHOWN  
INSTALL NOW TEMPORARILY  
IF USING TYPE 1, 2, OR 3 RAILS  
(2X)

Figure D-8 Attaching Front And Rear Bracket To Cabinet Section

---

**Important:** Do not tighten hardware completely.

---

6. Mount cabinet section into rack between upright rails using:
  - (4) Bar nuts (SPO-623 sold separately)
  - (6) #10 × 0.375 flat head countersunk Phillips SST screw (not supplied by Jonathan). Two for each side. See Figure D-9.

---

**Important:** The hardware used will change depending on the type of mounting hole available in your equipment rack. Ensure rails are level.

---

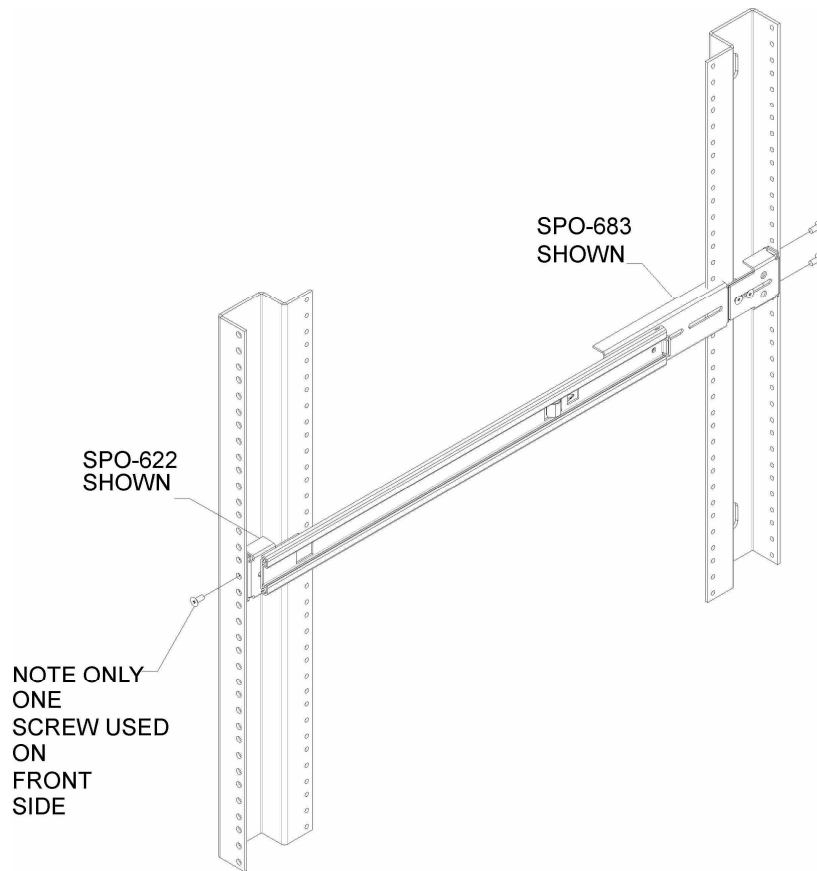


Figure D-9 Mounting Cabinet Section Into Rack

7. Install chassis.
8. Cycle chassis twice (push in and out two times).  
Ensure that rollers are engaged and the lock functions properly.
9. Remove chassis and securely tighten hardware from step 4. See Figure D-10.



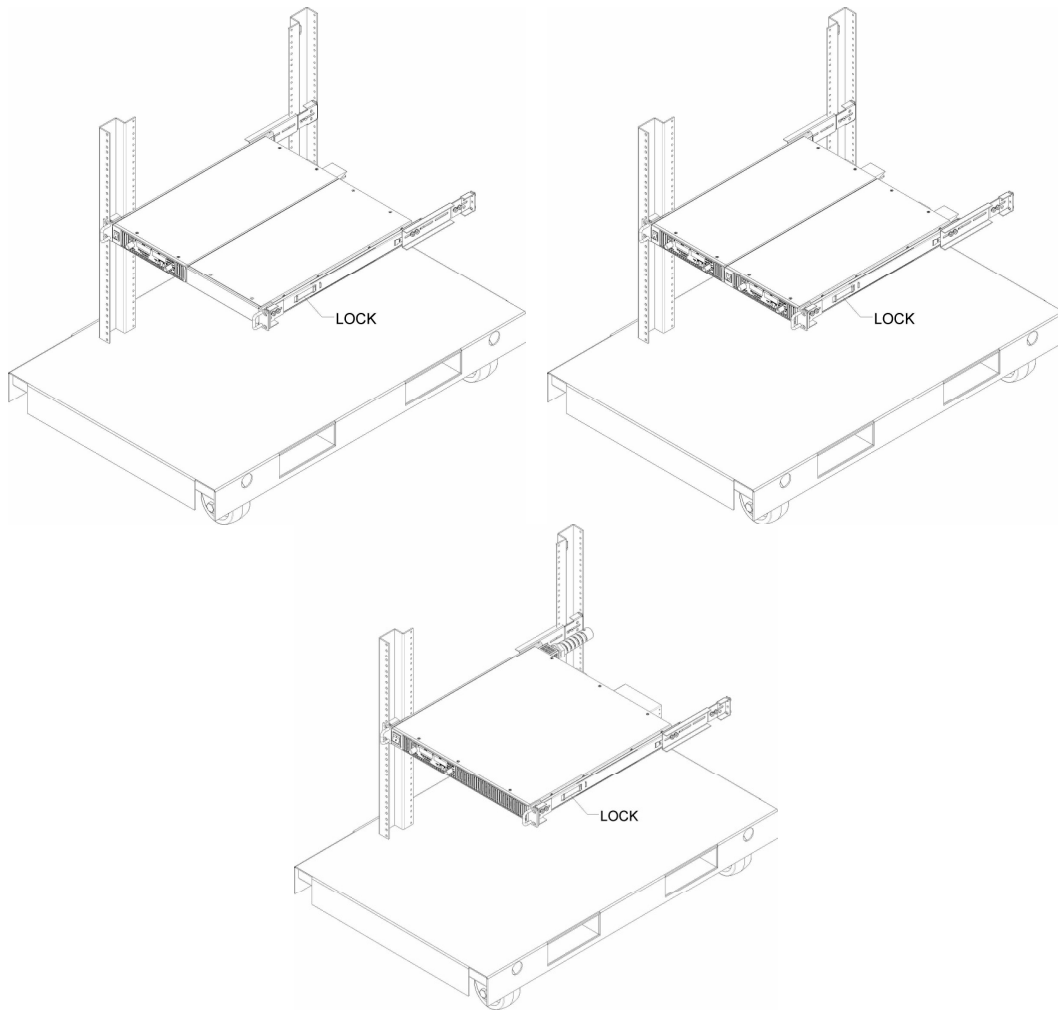


Figure D-10 Installing Chassis



# Index

## Numerics

- 7 segment font, use of vi
- 9-position mode control knob
  - illustrated 3-2
  - positions described 3-3

## A

- AC input connector
  - defined 2-5
  - illustrated 1-6, 1-8
- active power factor correction 1-2
- alarm conditions 3-19
- ALARM LED
  - clearing 3-21
  - illuminated 3-21
  - latched 3-16
- alarm output latching, defined 3-23
- alarm, masked, defined 3-22
- analog programming
  - defined 4-2
  - lines 4-3
- approvals
  - EMC C-6
  - safety C-6
- automatic mode crossover, described 3-13

## C

- calibration
  - exiting the mode 6-10
  - items 6-2
  - loading parameters 6-25
  - performing via SCPI commands 6-2
  - restoring factory calibration 6-26
  - saving parameters in a text file 6-25
  - storing parameters 6-25
- command string
  - punctuation not sent A-5

- command string punctuation
  - blank spaces A-4
  - colons A-4
  - commas A-4
  - semicolons A-4
- constant current mode, described 3-13
- constant voltage mode, described 3-13
- current configuration memory settings 3-35
- current share command 3-46
- current sharing, defined 3-42

## D

- DC output connector
  - illustrated 4-7
  - short circuit protection of 1-2
- DC output connectors, hole diameter 1-7, 1-8
- display
  - behavior of 2-8
  - font 3-2
  - front panel 1-5
  - output current 1-2
  - output current, illustrated 1-5
  - output voltage 1-2
  - output voltage, illustrated 1-5

## E

- ENET, cable specifications 5-15
- error messages, execution errors B-4
- execution errors, list of B-4

## F

- foldback
  - disabling 3-24
  - resetting activated 3-25
  - setting delay time 3-24
  - setting protection 3-24
- foldback mode, defined 3-24
- Front panel display
  - 7 segment font 3-9
  - illustrated 1-5

## G

gain calibration, effect of 6–6  
gain error, described 6–3

## I

IEEE  
  GPIB cable 5–15  
  Std. 488.1 1987 A–2  
  Std. 488.1999 2 17.1.2 5–52  
  Std. 488.2 1992 A–2  
  Std. 488.2 1999 12.5.2 5–52  
  Std. 488.2 1999 12.5.3 5–52  
  Std. 488.2 Register Model 5–27  
  Std. 488.2 registers 5–27  
  Std. 488.2 syntax error 5–33  
inactivity timeout  
  default 3–7  
  described 3–7

## L

local lockout, described 3–12  
local operation  
  coarse adjustment mode 3–3  
  fine adjustment mode 3–3

## M

menu system  
  navigating 3–2, 3–5  
  select and set model procedure 3–5  
  setting VOL and CUR modes 3–5

## N

Normal display mode, described 3–7

## O

offset calibration, effect of 6–6  
offset error, described 6–3

## P

parameter types A–7  
  boolean A–7  
  discrete A–7  
  numeric A–7  
  string A–7  
parameters, units of measure and multipliers  
  A–2

## S

SCPI A–4  
  command hierarchy A–3  
  command structure A–3  
  command summary A–14  
  command tree A–8  
  common commands A–6  
  conformance information A–2  
  described A–3  
  minimum and maximum A–6  
  parameter types A–7  
  requirements A–2  
  terminating characters A–6  
  using queries A–5  
select and set mode, described 3–5  
standard operation, described 3–12

## T

TIA/EIA-232 F A–2  
tracking mode, described 3–5

## U

user setting memory locations 1–2  
  described 3–7, 3–16  
  number available 3–36  
  stored values 3–36

