

DisplayPort 1.4 Transmitter Compliance and Debug Solution

Datasheet

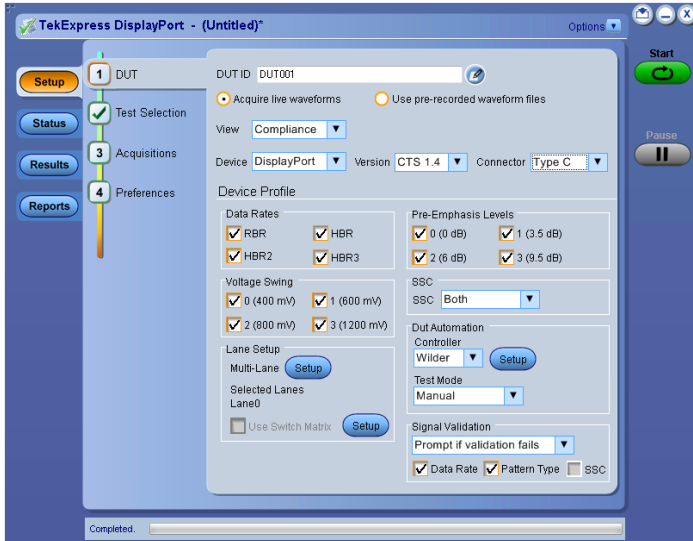

TekExpress DisplayPort 1.4 Transmitter Compliance Automation Software.

Tektronix provides the most comprehensive solutions to serve the needs of engineers designing DisplayPort silicon for computer systems and embedded systems, as well as those validating the physical-layer compliance of DisplayPort devices to the DisplayPort 1.4 Compliance Test Specification.

The Tektronix option DP14 application is compatible with Tektronix DPO/MSO 70000 DX/SX series oscilloscopes that are designed to meet the challenges of the next generation of display standards such as HDMI and DisplayPort.

Key offerings

- Complete automated compliance testing in less than 7 hours for data rates up to HBR2 and less than 11 hours for data rates up to HBR3
- Intelligent pattern recognition before test execution
- Fixture de-embed feature: Use the default filter file for de-embedding fixture effect or create a custom filter file using SDLA software to leverage the channel modeling and receiver equalization functionality
- Easy option to support repeatability of measurements
- Customization of reports according to tests, lanes, data rates or pass/fail results
- Timer pop-ups for **zero** user interaction during entire DisplayPort testing
- Enhanced TekExpress report with new measurement plots
- Single application for standard and Type-C DisplayPort testing

- 100% DisplayPort high speed transmitter test coverage
- Complete DUT automation for hands free testing
- Simplistic user experience with single UI for DUT configuration
- Optimized algorithms execute tests with improved accuracy
- Optional signal validation helps to detect anomalies quickly in the signal
- Reports available in mht, pdf and csv formats for advanced data analysis
- Compliance (TekExpress) and characterization (DPOJET) test support
- Support for DUT automation over SCPI based Programmatic Interface (PI)
- Automation support and scripting interface with iron python which supports socket based programming remote interface
- Supports manual and automated test modes for Type-C and Standard DP testing
- Stand-alone utility support for DPR-100 aux controller
- Capture and save DUT waveforms for offline analysis

DisplayPort 1.4 compliance/debug solution

Solution overview

One of the biggest challenges for DisplayPort compliance testing has been long test times and need for complete DUT automation. Most of the time, engineers need to spend a great deal of their time in front of the test setup monitoring the execution in progress. What makes this even more challenging is the integration of DisplayPort and USB Type-C and this challenge is reaching a wider audience.

Tektronix DisplayPort transmitter test solution solves this challenge by introducing a test application with an integrated Type-C and HBR3 data rate test support. The Tektronix DP12 software, combined with a DisplayPort Aux controller automates DisplayPort physical layer source compliance testing for standard and Type-C compliance needs. The TekExpress solution integrates with Unigraf DPR-100 reference sink and eliminates the need for user interaction during testing. you can simply select the desired tests to run and work on other tasks while the tests are being executed.

The new option DP14 supports transmitter compliance testing up to 8.1 Gbps (HBR3) as per the DisplayPort 1.4 spec. The application also includes support for debugging the setup using a new utility developed for controlling the DPR-100 controller.

Simple setup and test execution

Test setup and test execution is very simple with the DP1.4 automated software. The schematic corresponding to each test provides the details

of the connections. The TekExpress software provides a Graphical User Interface (GUI) and an intuitive workflow through setup and testing. When setting up a test, nothing can be simpler than hooking up the test system by looking at a schematic. View the schematic of the selected test with a click of a button.

DisplayPort Type-C setup overview

With the introduction of Type-C, DisplayPort broadens its reach and functionality by operating as one of the alternate modes of the USB over Type-C technology. This gives a great advantage to end user adopting Type-C who can integrate display, data and power needs into single physical connector. The test challenge here is the user now needs to test the same physical layer for three different standards for complete Type-C compliance.

For DisplayPort, there are some functional differences between a standard and Type-C DUT and the procedure involved to make these DUTs transmit a signal. The HPD (Hot Plug Detect) signal needed for a source DUT to start transmitting a signal is changed from interrupt based to message based in Type-C.

This is achieved by putting the Type-C DUT from default mode (USB) to DisplayPort mode by exchanging series of PD messages over CC (Configuration Channel) lines as per the power delivery spec. This requires a presence of a USB PD controller in the setup. Once this controller negotiates the messages and DUT goes into DisplayPort mode, it can be controlled using a second controller (test mode controller) to change the DUT configuration (control data rates, patterns, amplitude, pre-emphasis etc.).

The Tektronix Type-C setup below automates both the controllers using TekExpress framework and integrates the Type-C fixture to achieve complete 4-lane DUT automation using P7313SMA differential probes.

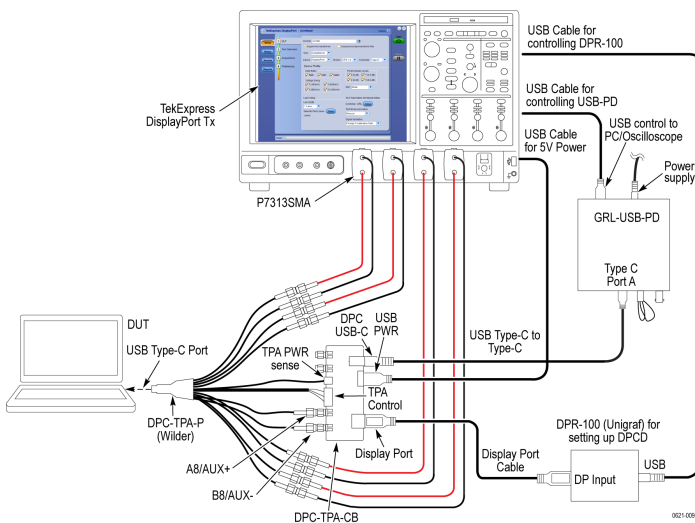

DisplayPort Type-C Setup

For testing ML0 and ML3 signals (i.e Pins A10-A11, B10-B11), connect recommended DC blocks at the output of the test fixture.

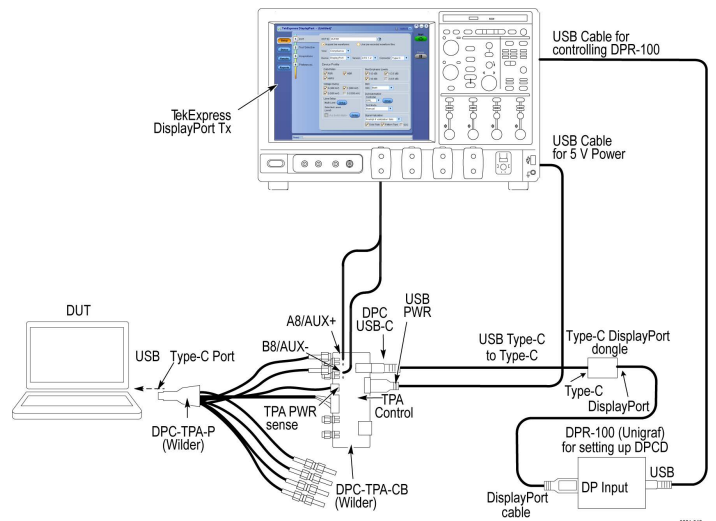
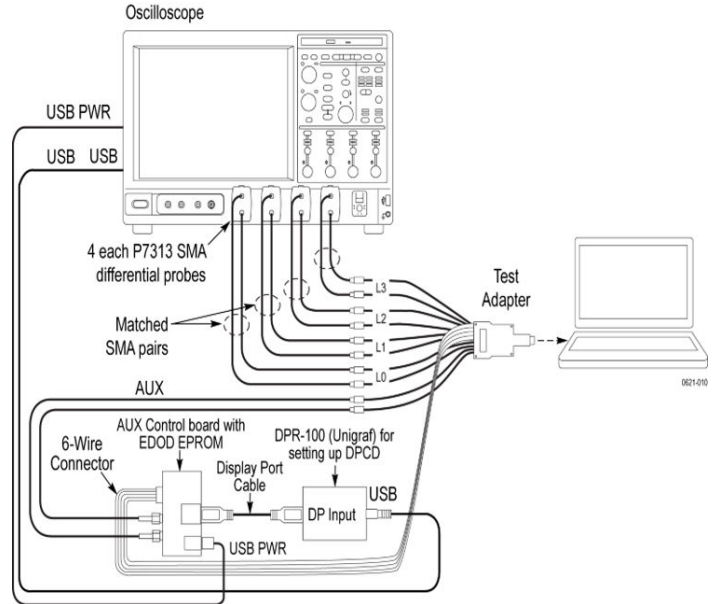

DisplayPort Type-C setup with dongle

DisplayPort transmitter test overview

DisplayPort sources (transmitters) have state control requirements in order to transmit the data patterns and signal properties required to demonstrate conformance as per the compliance test specification. The following properties and patterns need to be transmitted for full measurement coverage:

- Bit rates: RBR, HBR, HBR2, and HBR3
- Data patterns: D10.2, PRBS7, COMPEYE, PLTPAT, and TPS4
- FFE (pre-emphasis): 0 dB, 3.5 dB, 6 dB, and 9.5 dB
- Output levels: 400 mV, 600 mV, 800 mV, and 1200 mV
- SSC (spread spectrum): On/Off

TekExpress compliance solution overview

TekExpress provides automated test support for standard and Type-C DisplayPort compliance testing. The new and advanced TekExpress DisplayPort application leverages the features of the latest TekExpress 4.0 framework and optimizes the overall testing by nearly three times.

Tektronix TekExpress Automated Test Solution
 TekExpress DisplayPort

Setup Information			
DUT ID	DUT001	Scope Model	MSO73304DX
Date/Time	2021-07-16 17:19:10	Scope Serial Number	PQ00010
Device Type	DisplayPort	SPC, Factory Calibration	PASS,PASS
App Version	DisplayPort:10.3.7.29	Scope FW Version	10.12.1 Build 25
TekExpress Version	Framework: 4.9.0.5	DPOJET Version	10.12.1
Execution Mode	Pre-Recorded	ProbeCH1 Model	N.A
Overall Compliance Mode	Yes	ProbeCH1 Serial Number	N.A
Overall Result	Pass	ProbeCH2 Model	N.A
Overall Execution Time	0:01:46	ProbeCH2 Serial Number	N.A
DUT Automation Method	DPR-100	ProbeCH3 Model	N.A
Connector	Standard	ProbeCH3 Serial Number	N.A
CTS Version	CTS 1.4	ProbeCH4 Model	N.A
DPR100 Version	DP Rev 1.2	ProbeCH4 Serial Number	N.A
DUT COMMENT:	General Comment - DisplayPort		

Test Name Summary Table	
HBR2/HBR3 Level and Equalization Verification Testing	Pass
Total Measurements Executed : 18	Pass = 18 : Fail = 0 : Skipped = 0 : Error = 0 : Informative = 0

Detailed report with summary table

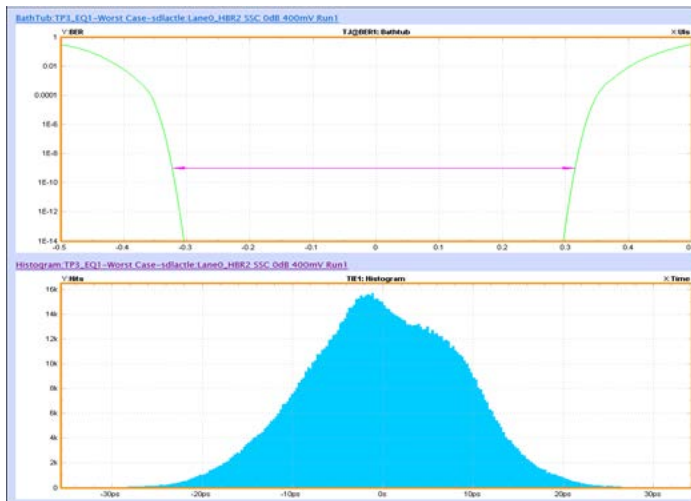

Bathtub and Histogram plot for HBR2 data rate at TP3_EQ

Lane	Test Id	Measur	Measured	Units	Test Result	Margin	Low Limit	High Limit
HBR2/HBR3 Level and Equalization Verification Testing								
Lane0	Test 3.4	0dB VTX_C	3.4072	dB	Pass	1.8072,1.0	1.6	4.5
Lane0	Test 3.4	0dB VTX_C	3.4072	dB	Pass	1.8072	1.6	N.A
Lane0	Test 3.4	400 mV TX	3.2471	dB	Pass	1.9471,0.7	1.3	4
Lane0	Test 3.4	400 mV TX	5.0506	dB	Pass	2.6506,0.9	2.4	6
Lane0	Test 3.4	600 mV TX	3.5485	dB	Pass	2.2485,0.4	1.3	4
Lane0	Test 3.4	600 mV TX	5.6074	dB	Pass	3.2074,0.3	2.4	6
Lane0	Test 3.4	400 mV VT	3.2471	dB	Pass	1.9471	1.3	N.A
Lane0	Test 3.4	400 mV VT	1.8036	dB	Pass	1.1036	0.7	N.A
Lane0	Test 3.4	600 mV VT	3.5485	dB	Pass	2.2485	1.3	N.A
Lane0	Test 3.4	600 mV VT	2.059	dB	Pass	1.359	0.7	N.A
Lane0	Test 3.4	400 mV PE	4.0511	dB	Pass	1.5246	2.5264	N.A
Lane0	Test 3.4	400 mV PE	6.6035	dB	Pass	2.4711	4.1324	N.A
Lane0	Test 3.4	600 mV PE	3.564	dB	Pass	0.7835	2.7805	N.A
Lane0	Test 3.4	600 mV PE	6.431	dB	Pass	1.7478	4.6832	N.A
Lane0	Test 3.4	400 mV Tr	4.0511	dB	Pass	4.0511	0	N.A
Lane0	Test 3.4	400 mV Tr	2.5524	dB	Pass	2.5524	0	N.A
Lane0	Test 3.4	600 mV Tr	3.564	dB	Pass	3.564	0	N.A
Lane0	Test 3.4	600 mV Tr	2.867	dB	Pass	2.867	0	N.A

CSV reporting for data analysis

Transmitter eye diagram measurement

The screen shots below show how an adaptive mask is used in a DP eye diagram measurement.

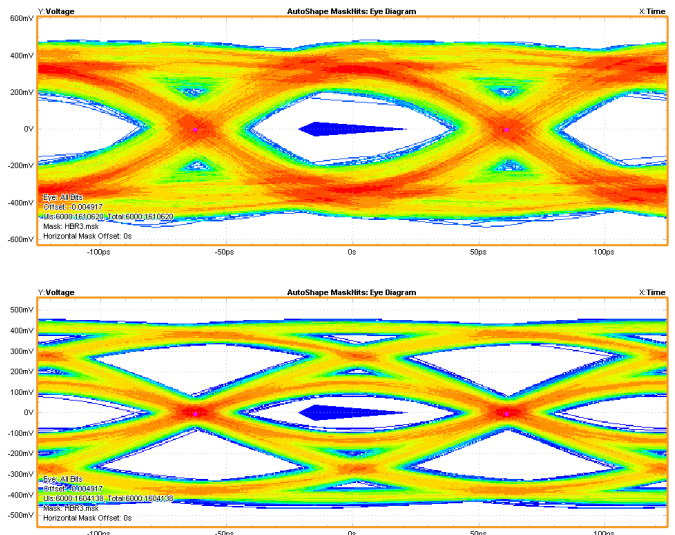

Eye-diagram with dynamic mask generation capability

According to the spec, the eye diagram needs to follow the mask limits:

- Eye diagram width is established at any passing location along 0mV.
- Eye diagram height (symmetric around 0mV) is established at any passing location between 0.375 to 0.625UI.

The measured eye must be equal to or larger than the appropriate eye mask.

The TekExpress application leverages the DPOJET analysis engine to generate a dynamic mask appropriate to the acquired signal and auto adjusts the position of the mask based on eye opening along the horizontal axis. The vertical coordinates are placed at the eye mask location corresponding to the max amplitude level.

Compliance to characterization support

Tektronix offers DisplayPort DPOJET essentials package which comes bundled with TekExpress that can be used to characterize a DUT and analyzing its finer behavior. It serves as an analysis tool when the DUT fails any portion of the compliance tests or you want to take a deeper look into the failures. All the compliance tests which are supported in the application and requires a single acquisition are supported in this package. You can build automation scripts around these measurements to setup a custom test environment.

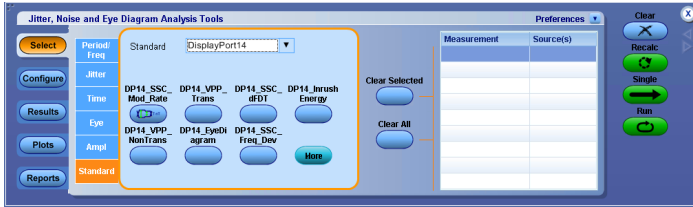

DisplayPort DPOJET Essentials package

You can enable this package by running 'DisplayPort 1.4 essentials' from the **Oscilloscope** → **Analyze** menu. The DisplayPort DPOJET measurement library helps in characterizing the silicon. Other advantage of this library is the ability to debug the measurement in case of failures. If any of the tests fail during compliance testing, you can tap into the DPOJET DisplayPort measurement library for a deeper dive into the failures such as eye diagram mask hit failures and look at relation between pre-emphasis level vs voltage swing tests to perform root cause analysis. The solution also gives users the flexibility to configure measurements with different settings, make configuration changes in existing measurements on the fly, and run tests in single-shot or free-run repetitive modes.

Introducing DPR-100 utility

This new utility helps verify setup connections and DUT behavior before running compliance tests and comes bundled with TekExpress DP 1.4 installer. The utility controls DPR-100 Aux controller to change the DUT settings like data rates, patterns and levels. The utility also helps control PD controller as part of DisplayPort Type-C setup.



DPR-100 utility

SDLA features

SDLA enables the user to probe and visualize data at the required location (de-embed / embed) using virtual probing through test points. It can remove (de-embed) the effects of the cables, probes, and fixtures to get more accurate measurement results. It can embed user defined channel models to simulate the signal at the end of the link. It can also be used to open a closed eye using receiver equalization, Continuous Time Linear Equalizer (CTLE), Decision Feedback (DFE), or Feed Forward Equalization (FFE). SDLA also has advanced analysis and modeling capabilities. One can view and measure multiple test points using DPOJET Jitter and Eye analysis comprehensive frequency and time domain plots, enable quick verification of S-parameters and test point transfer functions.

Switch matrix support

Switch matrix for DisplayPort (SWX-DP) is a software solution integrated with TekExpress DisplayPort application which simplifies the user experience to configure and setup automated multi-lane testing using RF switch.

The user can perform both differential and single ended tests as per DP 1.2/1.4 spec, without a need to make change connections. which significantly cuts down the test times.

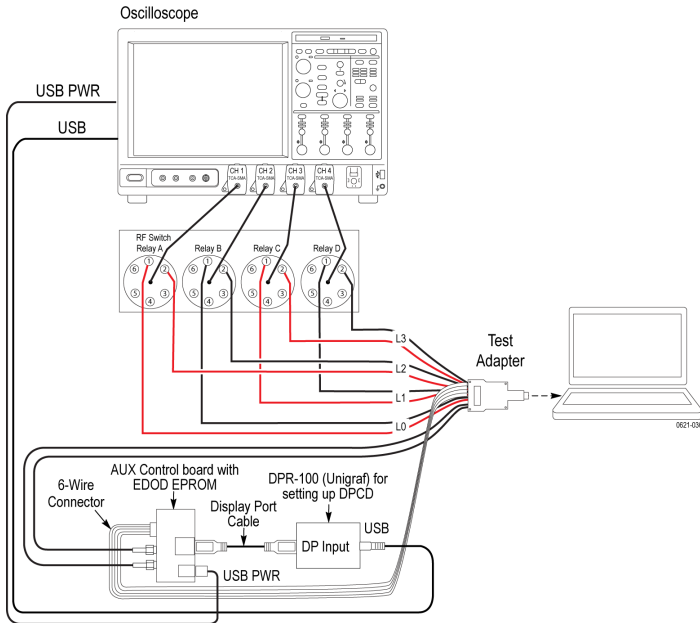

Key features of SWX-DP include:

- Auto detects the Keithley switch on the GPIB/LAN interface.
- De-embed using filter files – with multiple de-embed options (per relay, per input, etc.).
- Operates with TekExpress and DPOJET (Debug Mode).
- Save/recall switch configurations.
- Graphical view with print option to support hardware wiring.
- Graphical view integration with TekExpress report.
- Built-in error handling to support easy and error-free configuration.
- Support for custom input labels such as lane, port, etc. via XML file edits.
- Programmatic interface to support scripting and easy integration into user's automation environment.

Proposed measurements

List of supported measurements as per DP 1.4a Standard/Type-C CTS

- 3.1 Eye-diagram Testing
- 3.2 Non Pre-Emphasis Level Verification Testing
- 3.3 Pre-Emphasis Level Verification Testing
- 3.4 HBR2/HBR3 Level and Equalization Verification Testing
- 3.5 HBR2/HBR3 peak to peak voltage
- 3.6 Inter Pair Skew Test
- 3.7 Intra-Pair Skew Test
- 3.8 AC Common Mode Noise
- 3.9 Non ISI Jitter Measurements
- 3.11.1 Total Jitter (TJ) and Deterministic (DJ) Measurements
- 3.11 Random Jitter (RJ) Measurements
- 3.12 Main Link Frequency Compliance
- 3.13 Spread Spectrum Modulation Frequency
- 3.14 Spread Spectrum Modulation Deviation
- 3.15 dF/dt Spread Spectrum Deviation HF Variation
- 3.18 Dual mode TMD5 Clock
- 3.19 Dual-mode EYE Diagram Testing
- 9.1 AUX Manchester Channel Eye Test
- 9.2 AUX Manchester Channel Sensitivity Test
- 9.5 AUX Slew Rate
- 9.6 AUX Inrush Test

General characteristics

Physical characteristics

Configuration	Description
Oscilloscope	DPO/MSO71604SX/DX or above with Option DJA, 5XL and SDLA64 <ul style="list-style-type: none"> • 4 GHz and above is recommended for RBR • 8 GHz and above is recommended for HBR • 12.5 GHz and above is recommended for HBR2 • 16 GHz and above is recommended for HBR3
Probe	P7313SMA x 4 (for multilane testing up to HBR2) P7716-P77C292MM x4 or P7720-P77C292MM x4 (for multilane testing up to HBR3) P7625/P7633 x4 and P76CA-292 or P76CA-292C x4 (for multilane testing up to HBR3)

Ordering information

Software ordering information

DP1.4 software can be ordered separately as an upgrade option for a Tektronix oscilloscope or ordered along with a new oscilloscope. Please refer to <http://www.tektronix.com/displayport> for detailed product configuration on Source testing.

Option	Description
DP14	TekExpress DisplayPort - DisplayPort 1.4 Tx Compliance Solution (Requires Opt. DJA, SDLA, DP12); Node Lock
DPOFL-DP14	TekExpress DisplayPort - DisplayPort 1.4 Tx Compliance Solution (Requires Opt. DJA, SDLA, DP12); Floating License
DPO-UP DP14	TekExpress DisplayPort - DisplayPort 1.4 Tx Compliance Solution (Requires Opt. DJA, SDLA, DP12); Software Upgrade
DP12/DPOFL-DP12/DPOFT-DP12	TekExpress DP 1.2 – DisplayPort 1.2 Tx Compliance Automation Solution
SWX-DP/DPOFL-SWX-DP/DPOFT-SWX-DP	Switch Matrix option for DisplayPort testing
SDLA64	Serial Data Link Analysis 64-bit software

Recommended fixture and accessories for DisplayPort testing

Option	Description
PMCABLE1M (1x or 4x)	Precision Phase Matched Cable Pair, 1m
TF-DP-TPA-P	Standard DisplayPort Plug fixture
DP-TPA-A	DisplayPort Aux Control Adapter from Wilder Tech
DPR-100	DisplayPort Reference Sink Aux Controller from Unigraf (product #065910)
DPR-100 FW	DisplayPort Aux Refsink Controller (product #065053) and DisplayPort Reference Sink Aux Controller from Unigraf (product #065910)
GRL-USB-PD-C1	Type-C Power Delivery Controller from Granite River Labs
Type-C to Display Port Dongle	Dongle acts as a Alt mode controller
Fairview Microwave SDL3473 (4x)	Recommended DC Block for DP Type-C testing

Prerequisite host system software requirements for DisplayPort testing

Option	Description
Operating system	Windows 10, 64 bit
Software	<ul style="list-style-type: none"> Microsoft Internet Explorer 7.0 SP1 or later Adobe Reader 7.0 or equivalent software for viewing Portable Document Format (PDF) file Microsoft Excel 2007 or equivalent software for viewing Comma-separated Value (CSV) file

For more information about DisplayPort testing, visit our website www.tek.com/displayport

ASEAN / Australasia (65) 6356 3900
Belgium 00800 2255 4835*
Central East Europe and the Baltics +41 52 675 3777
Finland +41 52 675 3777
Hong Kong 400 820 5835
Japan 81 (120) 441 046
Middle East, Asia, and North Africa +41 52 675 3777
People's Republic of China 400 820 5835
Republic of Korea +822 6917 5084, 822 6917 5080
Spain 00800 2255 4835*
Taiwan 886 (2) 2656 6688

Austria 00800 2255 4835*
Brazil +55 (11) 3759 7627
Central Europe & Greece +41 52 675 3777
France 00800 2255 4835*
India 000 800 650 1835
Luxembourg +41 52 675 3777
The Netherlands 00800 2255 4835*
Poland +41 52 675 3777
Russia & CIS +7 (495) 6647564
Sweden 00800 2255 4835*
United Kingdom & Ireland 00800 2255 4835*

Balkans, Israel, South Africa and other ISE Countries +41 52 675 3777
Canada 1 800 833 9200
Denmark +45 80 88 1401
Germany 00800 2255 4835*
Italy 00800 2255 4835*
Mexico, Central/South America & Caribbean 52 (55) 56 04 50 90
Norway 800 16098
Portugal 80 08 12370
South Africa +41 52 675 3777
Switzerland 00800 2255 4835*
USA 1 800 833 9200

* European toll-free number. If not accessible, call: +41 52 675 3777

For Further Information. Tektronix maintains a comprehensive, constantly expanding collection of application notes, technical briefs and other resources to help engineers working on the cutting edge of technology. Please visit www.tek.com.

Copyright © Tektronix, Inc. All rights reserved. Tektronix products are covered by U.S. and foreign patents, issued and pending. Information in this publication supersedes that in all previously published material. Specification and price change privileges reserved. TEKTRONIX and TEK are registered trademarks of Tektronix, Inc. All other trade names referenced are the service marks, trademarks, or registered trademarks of their respective companies.