



ISN T8 IMPEDANCE STABILIZATION NETWORK (ISN) FOR UNSHIELDED BALANCED PAIRS



Impedance stabilization networks (ISN) are coupling/decoupling networks according to CISPR 22 (EN 55022) for measurement of conducted common mode disturbances of information technology equipment (ITE). The ISN is placed between the equipment under test (EUT) and the auxiliary equipment (AE) or load which is necessary for the operation of the EUT. The ISN establishes the common mode termination impedance seen by the telecommunication port during measurement.

The ISN T8 is designed for measurements on up to four unshielded single balanced pairs shown at D.3 (ISN with high longitudinal conversion loss (LCL) for use with one, two, three, or four unshielded balanced pairs) in CISPR 22, Ed.5.2, 2006 and EN 55022 Sept. 2006 (IEC/CISPR 22: 2005 modified). The ISN T8 consists of one basic network (ISN T800) with D-Sub-25- connectors and special adapter sets. A set of adapters consists of two pieces of LCL adapters to arrange the lines and realize longitudinal conversion loss (LCL)- requirements for the EUT-side in relation to the use cable category (cat.3, cat.5) and one piece of connection adapter arranges the lines for the AE-side. Teseq offers two different adapter sets – ADS T800 and ADS T8x0. ADS T800 gives the connection to RJ45 sockets with pin-arrangements of EIA/TIA T568A respectively T568B. The adapter set ADS T8x0 offers changeable pin-arrangements via 1 mm banana connectors for each pin combination of RJ11 / RJ45.



Technical specifications

- For use with one, two, three, or four unshielded balanced pairs
- CISPR 22, Ed.5.2, 2006 and EN 55022 Sept. 2006 (IEC/CISPR 22: 2005 modified) for Cat.3 and Cat.5
- 1000BaseT and PoE application
- Changeable pin-arrangements with RJ11 and RJ45

Frequency range:	150 kHz to 30 MHz
Line parameters:	1 up to 4 pair(s)
Power rating (EUT- and AE Port)	
AC max. voltage (line to ground):	63 V
DC max. voltage (line to ground):	100 V
Current max :	400 mA (line), 800 mA (pair)
Test voltage:	200 VDC, 2 sec
Common mode impedance (EUT Port) 150 kHz to 30 MHz:	150 Ω ±20 Ω
Phase angle (EUT Port) 150 kHz to 30 MHz:	0° ±20°
Coupling path (In/Out-port/EUT)	
Connection:	BNC 50 Ω
RF voltage:	<15 V
Frequency range:	150 kHz to 30 MHz
Voltage division factor (RF input to EUT port) 150 kHz to 30 MHz:	10 dB ±1 dB
Transmission bandwidth (wanted signal) EUT/AE B3 dB: *	> 100 MHz sin.
LCL (EUT) *)	
Cat. 3 150 kHz to 30 MHz:	55 dB to 39.3 dB ±3 dB
Cat. 5 150 kHz to 2 MHz:	65 dB ±3 dB
Cat. 5 2 MHz to 30 MHz:	65 dB to 49.3 dB +4.5/-3 dB
Decoupling of common mode disturbances (EUT / AE)	
150 kHz to 1.5 MHz:	≥35 dB to ≥55 dB
1.5 MHz to 30 MHz:	≥55 dB
Crosstalk (PSELFEXT) (EUT / AE) 1 MHz to 100 MHz:	≥61 dB to ≥21 dB
*) all balanced parameters are in relation to a symmetrical load of 100 Ω	

ISN T8

IMPEDANCE STABILIZATION NETWORK (ISN) FOR UNSHIELDED BALANCED PAIRS



ISN T8 with adapter sets in suitcase

Mechanical specifications

Size (W x H x D) (basic network):	105 x 65 x 110 mm ³
(basic network with adaptors):	105 x 65 x 190 mm ³
Weight:	approx. 550 g

Application

Pin-arrangement for EIA/TIA T568B

		Pair 1/ Pin 4,5	Pair 2/ Pin 1,2	Pair 3/ Pin 3,6	Pair 4/ Pin 7,8
Token ring, ISDN basic rate access / S0	RJ45	X		X	
ISDN primary rate access (2Mbps)	RJ45	X	X		
10BaseT, 100BaseTX	RJ45		X	X	
100BaseT4, 100Base VG-AnyLan, 1000BaseT	RJ45	X	X	X	X
ATM, FDDI, TP-PMD	RJ45		X		X
Dt. Telekom, UPO, AS400	RJ11	X			
IBM 3270	RJ45		X		

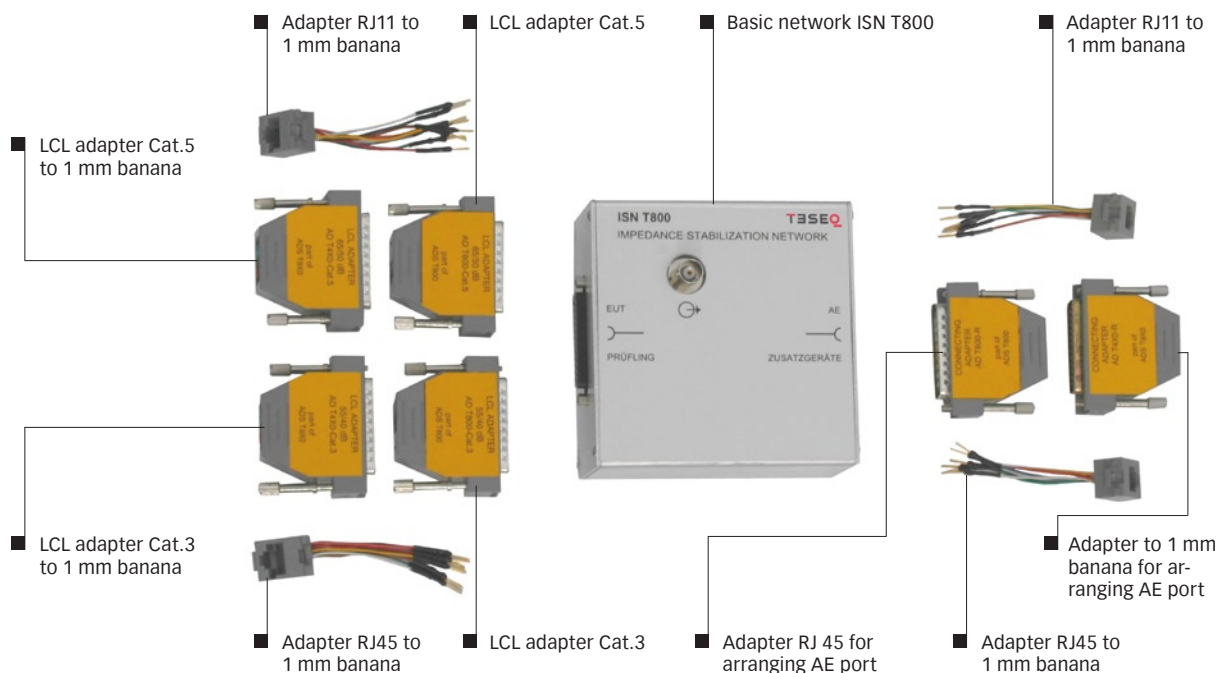

Teseq GmbH
Landsberger Str. 255 · 12623 Berlin · Germany
T +49 30 56 59 88 35 F +49 30 56 59 88 34
desales@teseq.com www.teseq.com



Advanced Test Solutions for EMC