

OPERATION AND MAINTENANCE MANUAL

**BENCHTOP TWO-PRESSURE
HUMIDITY GENERATOR
SERIES 2500**



**SERIES 2500
BENCHTOP TWO-PRESSURE
HUMIDITY GENERATOR**

**OPERATION AND
MAINTENANCE MANUAL**

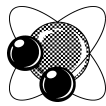

Copyright © 1991-2014
THUNDER SCIENTIFIC CORPORATION
623 WYOMING BLVD. SE
ALBUQUERQUE, NEW MEXICO 87123-3198

www.thunderscientific.com

Printed 2014

Tel: 505.265.8701 ✎ FAX: 505.266.6203

e-mail: support@thunderscientific.com

Document Edition 15 ♦ July 2014
Firmware Version 2.14

THUNDER SCIENTIFIC® is the registered trademark of Thunder Scientific Corporation.
All the information provided in this document is correct and true at the time of publication.
Thunder Scientific Corporation reserves the right to change any technical data without notice.



Model 2500 Two-Pressure Two-Temperature Humidity Generator

TABLE OF CONTENTS

Section 1 - GENERAL INFORMATION

| | | |
|----------|---|------|
| | List of Illustrations | |
| | List of Reference Drawings | |
| | Warranty | |
| 1.1 | INTRODUCTION ----- | 1-1 |
| 1.2 | PRINCIPLE OF OPERATION ----- | 1-1 |
| 1.2.1 | General Description----- | 1-1 |
| 1.2.2 | RH Formula For Ideal Gas----- | 1-2 |
| 1.2.3 | RH Formula For Air ----- | 1-4 |
| 1.2.4 | Pressure Ratio ----- | 1-5 |
| 1.2.5 | Effective Degree Of Saturation ----- | 1-5 |
| 1.2.6 | Enhancement Factor Ratio----- | 1-6 |
| 1.3 | SPECIFICATIONS----- | 1-7 |
| 1.3.1 | Facility Requirements ----- | 1-7 |
| 1.3.2 | Environmental ----- | 1-7 |
| 1.4 | COMPUTER CONTROL SYSTEM ----- | 1-8 |
| 1.4.1 | General Description----- | 1-8 |
| 1.4.2 | Central Processing Unit (STD-CPU)----- | 1-9 |
| 1.4.3 | Liquid Crystal Display (LCD)----- | 1-9 |
| 1.4.4 | Liquid Crystal Display Driver (STD-LCD) ----- | 1-9 |
| 1.4.5 | Keypad----- | 1-9 |
| 1.4.6 | Memory Card (STD-MEM) ----- | 1-9 |
| 1.4.7 | Analog to Digital Converter (STD-A/D) ----- | 1-9 |
| 1.5 | ELECTRICAL ----- | 1-10 |
| 1.5.1 | AC Power Distribution ----- | 1-10 |
| 1.5.2 | Power Supply 24 VAC ----- | 1-10 |
| 1.5.3 | Power Supply (STD-PS) ----- | 1-10 |
| 1.5.4 | Analog Inputs (STD-A/D) ----- | 1-11 |
| 1.5.4.1 | Temperature Measurement----- | 1-11 |
| 1.5.4.2 | Mass Flow Transducer (T1)----- | 1-11 |
| 1.5.4.3 | 50 PSIA Pressure Transducer (T2)----- | 1-11 |
| 1.5.4.4 | 150 PSIA Pressure Transducer (T3) ----- | 1-12 |
| 1.5.5 | Control Logic ----- | 1-12 |
| 1.5.5.1 | Air Supply Solenoid Valve (SOL1)----- | 1-12 |
| 1.5.5.2 | Refrigerant Solenoid Valve (SOL2) ----- | 1-12 |
| 1.5.5.3 | Pressure Bleed Solenoid Valve (SOL3)----- | 1-12 |
| 1.5.5.4 | Pressure Select Solenoid Valve (SOL5)----- | 1-13 |
| 1.5.5.5 | Heat Transfer Fluid Heater (H3) ----- | 1-13 |
| 1.5.5.6 | Presaturator Heaters (H1 & H2)----- | 1-13 |
| 1.5.5.7 | Expansion Valve Heaters (H4 & H5)----- | 1-13 |
| 1.5.5.8 | Fluid Circulation Pump (FP1) ----- | 1-13 |
| 1.5.5.9 | Refrigeration Compressor (C1)----- | 1-14 |
| 1.5.5.10 | Flow Valve (V1) - Actuation ----- | 1-14 |
| 1.5.5.11 | Expansion Valve (V2) - Actuation ----- | 1-14 |
| 1.5.5.12 | Reservoir Liquid Level Transducer (LL1)----- | 1-14 |
| 1.5.5.13 | Presaturator Liquid Level Transducer (LL2)----- | 1-15 |
| 1.5.5.14 | Console Fan (CF1)----- | 1-15 |

TABLE OF CONTENTS CONTINUED

| | | |
|-------|----------------------------------|------|
| 1.6 | PNEUMATIC SYSTEM ----- | 1-16 |
| 1.6.1 | General Description ----- | 1-16 |
| 1.6.2 | Presaturator ----- | 1-17 |
| 1.6.3 | Saturator ----- | 1-17 |
| 1.6.4 | Expansion Valve ----- | 1-17 |
| 1.6.5 | Reservoir ----- | 1-17 |
| 1.7 | HEAT TRANSFER FLUID SYSTEM ----- | 1-19 |
| 1.7.1 | General Description ----- | 1-19 |
| 1.7.2 | Fluid Heating ----- | 1-20 |
| 1.7.3 | Fluid Refrigeration ----- | 1-20 |

Section 2 – INSTALLATION

| | | |
|---------|---|-----|
| 2.1 | GENERAL ----- | 2-1 |
| 2.2 | FACILITIES REQUIRED ----- | 2-1 |
| 2.2.1 | Bench / Floor Space ----- | 2-1 |
| 2.2.2 | Power ----- | 2-1 |
| 2.2.3 | Air Supply (if used without pneumatic cart) ----- | 2-2 |
| 2.2.4 | Distilled Water Supply ----- | 2-2 |
| 2.3 | PREPARATION ----- | 2-2 |
| 2.3.1 | Chamber Fluid Filling ----- | 2-2 |
| 2.3.1.1 | Chamber Fluid Filling Procedure ----- | 2-2 |
| 2.3.2 | Positioning and Connections ----- | 2-3 |
| 2.3.2.1 | Pneumatic Cart ----- | 2-3 |
| 2.3.2.2 | Bench Space ----- | 2-4 |
| 2.3.2.3 | Power ----- | 2-4 |
| 2.3.2.4 | Air Supply ----- | 2-5 |

Section 3 – OPERATION

| | | |
|---------|--|------|
| 3.1 | GENERAL ----- | 3-1 |
| 3.2 | STANDARD OPERATING PROCEDURES ----- | 3-1 |
| 3.2.1 | Power-Up ----- | 3-1 |
| 3.2.2 | Control/Display Screen ----- | 3-1 |
| 3.2.2.1 | Changing the Display Contrast ----- | 3-3 |
| 3.2.3 | Changing Setpoints ----- | 3-3 |
| 3.2.4 | Changing Units ----- | 3-5 |
| 3.2.5 | Control Modes ----- | 3-5 |
| 3.2.6 | Run/Stop ----- | 3-6 |
| 3.2.7 | Printer (optional) ----- | 3-7 |
| 3.2.8 | Power-Off ----- | 3-7 |
| 3.2.8.1 | Maintenance Power-Off ----- | 3-8 |
| 3.2.9 | Filling the Reservoir ----- | 3-8 |
| 3.3 | EDITING SYSTEM COEFFICIENTS AND PARAMETERS ----- | 3-9 |
| 3.3.1 | Edit Mode ----- | 3-9 |
| 3.3.2 | Coefficients and Parameters ----- | 3-11 |

TABLE OF CONTENTS CONTINUED

| | | |
|---------|---------------------------------------|------|
| 3.3.2.1 | Temperature Coefficients ----- | 3-11 |
| 3.3.2.2 | Reference Resistor Coefficients ----- | 3-12 |
| 3.3.2.3 | Pressure Coefficients----- | 3-12 |
| 3.3.2.4 | Flow Coefficients----- | 3-13 |
| 3.3.2.5 | Console Port Parameters ----- | 3-14 |
| 3.3.2.6 | Printer Port Parameters ----- | 3-15 |
| 3.3.2.7 | Time and Date ----- | 3-15 |

Section 4 - CALIBRATION AND MAINTENANCE

| | | |
|---------|--|------|
| 4.1 | GENERAL ----- | 4-1 |
| 4.2 | CALIBRATION ----- | 4-1 |
| 4.2.1 | A/D Board (STD-A/D) ----- | 4-2 |
| 4.2.2 | Temperature Calibration ----- | 4-2 |
| 4.2.2.1 | Temperature Calibration Procedure----- | 4-3 |
| 4.2.3 | Pressure Transducer Calibration ----- | 4-7 |
| 4.2.3.1 | Pressure Calibration Procedure----- | 4-7 |
| 4.2.4 | Flow Transducer Calibration ----- | 4-11 |
| 4.2.4.1 | Flow Calibration Procedure----- | 4-11 |
| 4.2.5 | Printing the Calibration Report ----- | 4-14 |
| 4.3 | ROUTINE MAINTENANCE----- | 4-17 |
| 4.3.1 | Console Intake: Monthly----- | 4-17 |
| 4.3.2 | Chamber Fluid Level: Yearly ----- | 4-17 |
| 4.3.3 | Pre-saturator Drain: Yearly ----- | 4-17 |
| 4.3.4 | Mobile Pneumatic Cart: Daily----- | 4-17 |
| 4.4 | ERROR CODES and TROUBLESHOOTING----- | 4-18 |

Section 5 - PARTS LISTS

| | | |
|-----|----------------------------------|-----|
| 5.1 | COMPUTER CONTROL SYSTEM ----- | 5-1 |
| 5.2 | ELECTRICAL SYSTEM----- | 5-1 |
| 5.3 | PNEUMATIC SYSTEM ----- | 5-2 |
| 5.4 | HEAT TRANSFER FLUID SYSTEM ----- | 5-2 |
| 5.5 | REFRIGERATION SYSTEM ----- | 5-3 |
| 5.6 | PNEUMATIC CART ----- | 5-3 |
| 5.7 | AIR BOX ELECTRICAL ----- | 5-3 |
| 5.8 | OPTION INDICATORS----- | 5-4 |

LIST OF ILLUSTRATIONS

| FIGURE | TITLE | PAGE |
|--------|--|------|
| 1-1 | Two Pressure Elemental Schematic ----- | 1-2 |
| 1-2 | STD Bus Diagram----- | 1-8 |
| 1-3 | Pneumatic System----- | 1-16 |
| 1-4 | Heat Transfer Fluid System----- | 1-19 |
| 1-5 | Refrigeration System ----- | 1-20 |
| 2-1 | Mechanical / Utility----- | 2-1 |
| 2-2 | Chamber Fluid Fill Port Location----- | 2-3 |
| 2-3 | Generator / Cart Mechanical----- | 2-3 |
| 2-4 | Pneumatic Cart w/Air Compressor Sound Enclosure----- | 2-4 |
| 2-5 | Pneumatic Cart w/o Air Compressor----- | 2-5 |

LIST OF REFERENCE DRAWINGS

| DRAWING # | DRAWING TITLE |
|----------------|--|
| 91D25901 ----- | Layout, Utility / Mechanical |
| 91D25902 ----- | Probe Location |
| 91D25903 ----- | Circuit Card and Component Location |
| 91D25904 ----- | Electrical Sub Panel Layout |
| 91D25905 ----- | Terminal Layout |
| 91S25906----- | AC / DC Power |
| 91S25907----- | Solid State Relay Module Board |
| 91S25908----- | Compressor / Heater Schematic |
| 91S25909----- | Liquid Level / Speaker Schematic |
| 91S25910----- | Flow Valve (V1) Schematic |
| 91S25911----- | Expansion Valve (V2) Schematic |
| 91S25912----- | Temperature Probe / Transducer Schematic |
| 91D25913 ----- | STD Bus Diagram |
| 91S25914----- | Display Block Diagram |
| 91D25915 ----- | RS-232C Console / Printer |
| 91S25916----- | Pneumatic System |
| 91S25917----- | Heat Transfer Fluid System |
| 91S25918----- | Refrigeration System |
| 98D25919 ----- | Layout, Compressor Enclosure w/Cart |
| 91S25921----- | Schematic, Cart - Pneumatic System |
| 97D25924 ----- | Instructions, Chamber Fluid Filling |
| 97D25926 ----- | Cart Mechanical Dimensions R Model |
| 08S25942----- | 2500 Fuse Upgrade Schematic |
| ACS2031 ----- | Schematic, ACS Twin Electrical |

WARRANTY

Thunder Scientific Corporation (TSC) warrants, to the Buyer, the Product manufactured by TSC to be free of defects in material and workmanship under normal use and service and to be free from inadequate mechanical design when operated within the specified design limitations for a period of twelve months from date of acceptance. TSC's obligation under this warranty shall be limited to the following: the Product is returned to TSC with transportation charges prepaid and that TSC's examination reveals the Product to be defective. TSC, at its option, shall either refund to the Buyer the purchase price of the product or repair or replace at TSC's plant, any part or parts of the Product which is or are defective. This warranty shall not apply to any Product which has been maintained, handled, stored, repaired or altered in any manner, or by anyone other than an authorized TSC representative, so as to affect adversely such Product or which has been subject to improper installation, misuse, negligence, accident or corrosion. THIS WARRANTY IS EXCLUSIVE AND IN LIEU OF ANY WARRANTY OF MERCHANTABILITY, FITNESS FOR A PARTICULAR PURPOSE OR ANY OTHER WARRANTY, WHETHER EXPRESS OR IMPLIED, AND ALL OTHER LIABILITIES AND OBLIGATIONS ON THE PART OF TSC; TSC SHALL NOT BE LIABLE FOR ANY OTHER CLAIMS OR DAMAGES, EITHER DIRECT OR CONSEQUENTIAL, ARISING DIRECTLY OR INDIRECTLY OUT OF SUPPLYING THE PRODUCT. All warranties, express or implied, with respect to any device or component not manufactured by TSC but incorporated into its Product are the responsibility of the original manufacturer and shall not affect or apply to TSC.

2500 Item Check List

1. Certificate of Calibration (In Manual)

2. Operation and Maintenance Manual

3. HumiCalc[®] with Uncertainty Software

4. 2500 ControLog[®] Software

5. Chamber Insulation Foam

6. Chamber Port Foam Plug

7. Power Cable

8. Torx Driver with Screws

9. Reservoir Fluid Funnel

10. Chamber Fill Funnel

11. Elbow, ¼ Flare x ¼ MPT Brass

12. Communication Cables (Printer & Computer)

13. Chamber Fluid

PROPYLENE GLYCOL 3 bottles for the R, 4 bottles for the ST

1. **Optional Equipment** – Air compressor power cable

2. **ACS-517B** – Air Compressor System Manual

3. **Air Hose** – On Air Box

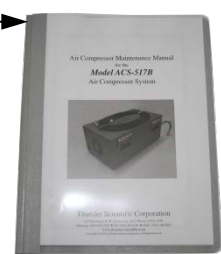

Suomi

Tämä tuote noudattaa WEEE-direktiivin (2002/96/EY) merkintävaatimuksia. Kiinnitetty etiketti osoittaa, että tätä sähkö-/elektroniikkalaitetta ei saa hävittää kotitalousjätteissä.

Tuoteluokka: Viitaten WEEE-direktiivin liitteessä I mainittuihin laitteisiin, tämä tuote on luokiteltu luokan 9 "Tarkkailu- ja ohjauslaitteet" -tuotteeksi.



Ei saa heittää kotitalousjätteiden mukana!

Palauta tarpeettomat tuotteet ottamalla yhteyttä valmistajan websivustoon, joka mainitaan tuotteessa tai paikalliseen myyntitoimistoon tai jakelijaan.

Dansk

Dette produkt er i overensstemmelse med kravene om afmærkning i WEEE-direktivet (2002/96/EC). Det påhæftede mærkat angiver, at du ikke må bortskaffe dette elektriske/elektroniske produkt via husholdningsaffald.

Produktkategori: Med reference til kravene i WEEE-direktivets bilag I klassificeres dette produkt som et produkt til "overvågning og kontrolinstrumentering" i kategori 9.



MÅ ikke bortskaffes via husholdningsaffald!

Hvis du vil returnere uønskede produkter, skal du besøge producentens websted, som vises på produktet, eller den lokale forhandler eller distributør.

English

This product complies with the WEEE Directive (2002/96/EC) marking requirements. The affixed label indicates that you must not discard this electrical/electronic product in domestic household waste.

Product Category: With reference to the equipment types in the WEEE Directive Annex I, this product is classed as category 9 "Monitoring and Control Instrumentation" product.



Do not dispose in domestic household waste!

To return unwanted products, contact the manufacturer's web site shown on the product or your local sales office or distributor.

Français

Ce produit est conforme aux normes de marquage de la directive DEEE (2002/96/CE). La présence de cette étiquette indique que cet appareil électrique/électronique ne doit pas être mis au rebut avec les déchets ménagers.

Catégorie de DEEE : Cet appareil est classé comme catégorie 9 parmi les « instruments de surveillance et de contrôle » en référence aux types d'équipements mentionnés dans l'Annexe I de la directive DEEE.



Ne pas éliminer avec les autres déchets ménagers !

Pour renvoyer les produits indésirables, contacter le site Web du fabricant mentionné sur le produit, ou son distributeur ou bureau de ventes local.

Español

Este producto cumple la Directiva WEEE (2002/96/EC) sobre requisitos de las marcas. La etiqueta que lleva pegada indica que no debe desechar este producto eléctrico o electrónico con los residuos domésticos.

Categoría del producto: con referencia a los tipos de equipo del anexo I de la Directiva WEEE, este producto está clasificado como categoría 9 de "Instrumentación de supervisión y control".



¡No lo deseche con los residuos domésticos!

Para devolver productos que no desee, póngase en contacto con el sitio Web del fabricante mostrado en el producto, o con la oficina de ventas o distribuidor local.

Deutsch

Dieses Produkt stimmt mit den Kennzeichnungsanforderungen der WEEE-Richtlinie (2002/96/EC) überein. Das angebrachte Etikett weist darauf hin, dass dieses elektrische/elektronische Produkt nicht in Hausmüll entsorgt werden darf.

Produktkategorie: In Bezug auf die Gerätetypen in Anhang I der WEEE-Richtlinie ist dieses Produkt als Kategorie 9 "Überwachungs- und Kontrollinstrument" klassifiziert.



Nicht in Hausmüll entsorgen!

Zur Rückgabe von unerwünschten Produkten die auf dem Produkt angegebene Website des Herstellers oder die zuständige Verkaufsstelle bzw. den zuständigen Fachhändler konsultieren.

Italiano

Questo prodotto risponde ai requisiti sull'etichettatura stabiliti nella Direttiva RAEE (2002/96/CE). Il simbolo apposto indica che non si deve gettare questo prodotto elettrico o elettronico in un contenitore per rifiuti domestici.

Categoria del prodotto: con riferimento ai tipi di apparecchiature elencate nell'Allegato 1 della Direttiva RAEE, questo prodotto rientra nella categoria 9 "Strumenti di monitoraggio e di controllo".



Non gettare in un contenitore per rifiuti domestici.

Per restituire prodotti non desiderati, visitare il sito Web del produttore riportato sul prodotto o rivolgersi al distributore o all'ufficio vendite locale.

Português

Este produto está em conformidade com as exigências de rotulagem da Directiva WEEE (2002/96/EC). O rótulo afixado indica que o utilizador não deve deitar este produto eléctrico/electrónico fora juntamente com o lixo doméstico.

Categoria do produto: No que se refere aos tipos de equipamento listados no Anexo I da Directiva WEEE, este produto está classificado como produto da categoria 9, "Instrumentação de monitorização e controlo".



Não deite fora juntamente com o lixo doméstico!

Para devolver produtos indesejados, contacte o fabricante através do Website constante do produto ou contacte o seu representante de vendas ou distribuidor local.

Nederlands

Dit product voldoet aan de merktekenvereisten van de AEEA-richtlijn (2002/96/EG). Het aangebrachte merkteken duidt erop dat dit elektrische/elektronische product niet met het huishoudelijk afval mag worden afgevoerd.

Productcategorie: Met betrekking tot de apparatuurcategorieën van bijlage I van de AEEA-richtlijn, valt dit product onder categorie 9 'meet- en controle-instrumenten'.



Niet afvoeren met huishoudelijk afval!

Om ongewenste producten te retourneren, neemt u contact op met de website van de fabrikant die op het product staat vermeld, of met uw plaatselijke verkoopkantoor of distributeur.

Svenska

Denna produkt uppfyller märkningskraven enligt WEEE Directive (2002/96/EC). Märkningsetiketten anger att du inte får kassera denna elektriska/elektroniska produkt tillsammans med vanliga hushållssopor.

Produktkategori: Med hänvisning till utrustningstyperna i WEEE Directive Annex I, är denna produkt klassad som kategori 9 "Monitoring and Control Instrumentation" (Instrument för övervakning och styrning).



Får ej kasseras tillsammans med vanliga hushållssopor!

Returnera ej önskvärda produkter genom att gå till tillverkarens webbplats, vilken anges på produkten, eller till det lokala försäljningskontoret eller distributören.

Norsk

Dette produktet oppfyller bestemmelsene ifølge WEEE-direktiv (2002/96/EC) med krav til merking. Påsatt merke viser at det ikke er tillatt å kassere dette elektriske/elektroniske produktet sammen med husholdningsavfall.

Produktkategori: På grunnlag av utstyrstypene i WEEE-direktivet, vedlegg I, er dette produktet klassifisert i kategori 9, "Instrumentering for overvåking og kontroll".



Må ikke kastes sammen med husholdningsavfall!

Ved behov for returforsendelse av uønskede produkter må du gå til produsentens nettside som er angitt på produktet, eller du må kontakte det lokale salgskontoret eller den lokale forhandleren.

GENERAL INFORMATION

1.1 INTRODUCTION

The Model 2500 Benchtop Humidity Generator is a self contained facility capable of producing known humidity values using the fundamental principle of the "two pressure" generator developed by NIST. This system is capable of continuously supplying accurately known humidity values for instrument calibration, evaluation and verification.

The 2500 operates using an on board computer and control system to perform calculation and control functions. The Computer Control System utilizes a multifunction STD Bus CPU in conjunction with other STD Bus peripheral cards for control and is incorporated into the benchtop humidity generator. Peripheral equipment, such as a printer or computer, may be connected using the bi-directional RS-232C interfaces.

Humidity and temperature setpoint values are input by the operator from the front panel keypad. Visual indications of system status are displayed in real time on the Liquid Crystal Display. The automatic features of this system allow the 2500 to generate humidity and temperature setpoints completely unattended. This automated approach frees the operating technician from the task of system monitoring and adjustments, allowing him time to perform other vital tasks.

1.2 PRINCIPLE OF OPERATION

1.2.1 General Description

Operation of the 2500 humidity generator is based on the two-pressure method of producing known atmospheres of relative humidity and assumes that the water vapor pressure remains a fraction of the total pressure, known as Dalton's Law of Partial Pressure. Dalton's Law states that the pressure exerted by a mixture of gases in a given volume at some temperature is equal to the sum of the pressures which would be exerted by each individual gas if it alone occupied the volume at the same temperature.

The two pressure method (shown in elemental schematic form in figure 1-1) involves saturating air, or some other gas such as nitrogen, with water vapor at a given pressure and temperature. The saturated gas then flows through an expansion valve where it is isothermally reduced to chamber pressure. If the temperature of the gas is held constant during pressure reduction, the humidity, at chamber pressure, may then be approximated as the ratio of two absolute pressures.

$$\%RH \approx \frac{P_{chamber}}{P_{saturation}} \cdot 100$$

Humidity produced in the test chamber of this system does not depend on devices such as psychrometers, dewpoint hygrometers, or solid state sensors for the measurement of water vapor content. Humidity that is produced is solely dependent on the measurement of absolute pressures and on the maintenance of isothermal conditions. Precision humidity generation is determined by the accuracy of these pressure measurements and uniformity of temperature throughout the generating system.

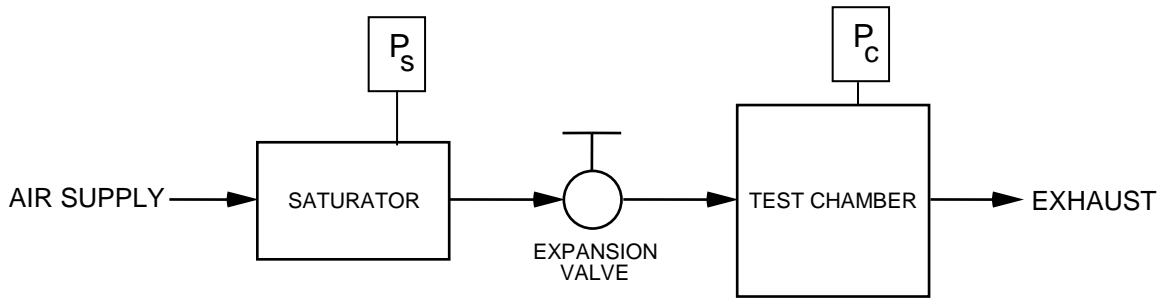

Figure 1-1

1.2.2 RH Formula For Ideal Gas

The relative humidity formula, equation 1 given in section 1.2.1, is a correct relationship between pressures and relative humidity when dealing with perfectly isothermal conditions and perfectly ideal gases. However, under dynamic conditions where some slight temperature differences do exist and since gases do not behave ideally, any expectation of this equation to accurately represent the actual relative humidity would be overly optimistic. In its strictest form, relative humidity is defined in terms of mole fractions and is given as

$$\%RH = \frac{X_v}{X_w} \Big|_{P,T} \cdot 100$$

where X_v = the mole fraction of water vapor in a sample of moist air at a specific pressure, P , and temperature, T , and

X_w = the mole fraction of water vapor which would exist in a sample of air if it were saturated with water vapor at the same pressure, P , and temperature, T , as the unsaturated sample X_v .

The mole fraction of water vapor in a sample of gas is given by

$$X = \frac{P_v}{P}$$

where P_v = the partial pressure of the gas which is exerted by the water vapor constituent alone, and

P = the absolute (or total) pressure of the gas, which is also equal to the sum of the partial pressures exerted by the water vapor and dry air constituents.

When a gas is fully saturated with water vapor, the partial pressure, P_v , exerted by the water vapor constituent is a known quantity, $e_w(T)$, and is termed "the saturation vapor pressure of air with respect to water". Since, at saturation, $P_v = e_w(T)$, the mole fraction equation of a saturated gas may be written as

$$X = \frac{e_w(T)}{P}$$

where $e_w(T)$ = the saturation vapor pressure of air with respect to water (at temperature T), and is the partial pressure exerted by the water vapor constituent,
and

P = the absolute (or total) pressure of the gas.

The mole fraction of water vapor which would exist in a saturated gas sample at the chamber pressure, P_c , and chamber temperature, T_c , would be the quantity, X_w , which is needed to calculate the relative humidity relationship previously discussed. Here, the mole fraction, under saturated conditions, may be expressed by

$$X_w = \frac{e_w(T_c)}{P_c}$$

where $e_w(T_c)$ = the saturation vapor pressure of air with respect to water at the chamber temperature, T_c , and

P_c = the measured absolute pressure in the chamber expressed in the same units as $e_w(T_c)$.

The other quantity, X_v , required for the calculation of relative humidity, is that mole fraction of water vapor which actually exists in the air sample within the chamber at pressure P_c , and temperature T_c . If the chamber pressure, P_c , were used in the calculation of the mole fraction X_v , the expression would be

$$X_v = \frac{P_v}{P_c}$$

which would require direct measurement of the water vapor content. However, this requirement is eliminated by using the relationship

$$\frac{e_w(T_s)}{P_s} = \frac{P_v}{P_c}$$

where $e_w(T_s)$ = the saturation vapor pressure of air with respect to water at the temperature of saturation, T_s , (the saturation temperature), and

P_s = the measured absolute (or total) pressure at which the sample is saturated (the saturation pressure).

The basis for this relationship lies in the fact that the number of molecules of the constituents within a sample of gas remain constant regardless of the pressure or temperature, provided that the temperature or pressure applied does not cause a change in phase (i.e., gas to liquid).

Since the saturation vapor pressure, $e_w(T)$, is a well known function of the temperature alone, the total pressure at saturation, P_s , may be adjusted to any reasonable value to achieve the desired mole fraction of water vapor. Relying on this relationship, the mole fraction of water vapor entering the chamber (and at chamber temperature) may be written as that mole fraction of water vapor existing in the saturator at the saturation pressure and temperature. Thus,

$$X_v = \frac{e_w(T_s)}{P_s}$$

The relative humidity may now be expressed in terms of these other quantities by returning to the original definition and substituting in the appropriate expressions.

$$\begin{aligned} \%RH &= \frac{X_v}{X_w} \Big|_{P,T} \cdot 100 \\ &= \frac{\left(\frac{e_w(T_s)}{P_s} \right)}{\left(\frac{e_w(T_c)}{P_c} \right)} \cdot 100 \end{aligned}$$

After rearrangement of terms, the relative humidity formula for ideal gases may then be expressed as

$$\%RH = \frac{e_w(T_s)}{e_w(T_c)} \cdot \frac{P_c}{P_s} \cdot 100 \quad \text{eq.(2)}$$

where $e_w(T_s)$ = the saturation vapor pressure at the saturation temperature, T_s ,

$e_w(T_c)$ = the saturation vapor pressure at the chamber temperature, T_c ,

P_c = the absolute pressure in the chamber, and

P_s = the absolute pressure in the saturator.

1.2.3 RH Formula For Air

Air, a mixture of gases with varying compressibilities, exhibits non-ideal properties, which affect the saturation vapor pressure, $e_w(T)$. The saturation vapor pressures, $e_w(T_s)$ and $e_w(T_c)$, in the relative humidity formula of 1.2.2, must be replaced by their "effective" saturation vapor pressures which are related to the ideal SVP by

$$e_w'(P,T) = f_w(P,T) e_w(T)$$

where $e_w'(P,T)$ = the "effective saturation vapor pressure of air with respect to water" at absolute pressure, P , and temperature, T , and

$f_w(P,T)$ = the "enhancement factor for moist air" at pressure, P , and temperature, T .

The relative humidity formula for air, based on the effective saturation vapor pressures, is then written as

$$\%RH = \frac{e_w'(P_s, T_s)}{e_w'(P_c, T_c)} \cdot \frac{P_c}{P_s} \cdot 100$$

and, after making the appropriate substitutions, is expressed by

$$\%RH = \frac{f_w(P_s, T_s)}{f_w(P_c, T_c)} \cdot \frac{e_w(T_s)}{e_w(T_c)} \cdot \frac{P_c}{P_s} \cdot 100 \quad \text{eq.(3)}$$

It can now be seen by inspection of the relative humidity formula, expressed in its final form in equation 3, that known relative humidities may be accurately generated, using air, through measurement and control of pressure and temperature alone.

1.2.4 Pressure Ratio

The term $\frac{P_c}{P_s}$, in equation 2 of section 1.2.2 and equation 3 of section 1.2.3, is simply the ratio of the chamber pressure to the saturator pressure. This is the "idealistic" portion of the relative humidity formula which ignores minor temperature differences between the saturator and chamber. It also assumes that moist air behaves as an ideal gas. This ratio closely approximates the actual relative humidity, and is often used alone to express the humidity when ease of calculation outweighs the need for the additional accuracy provided by the temperature and pressure corrections. The pressures P_c and P_s are measured directly through the use of high accuracy absolute pressure transducers.

1.2.5 Effective Degree Of Saturation

The term $\frac{e_w(T_s)}{e_w(T_c)}$, in equation 2 of section 1.2.2 and equation 3 of section 1.2.3, referred to as the "effective" degree of saturation, is a temperature correction ratio which accounts for super-saturation and under-saturation of the gas in the saturator, at temperature T_s , with respect to the chamber temperature, T_c , due to any small temperature differences which may exist between them. When the chamber and saturation temperatures are identically matched, the effective degree of saturation is exactly equal to 1.0 and no temperature correction takes place. To obtain the effective degree of saturation when temperature differences do occur, the saturation vapor pressures at the saturation and chamber temperatures, T_s and T_c , must be calculated. There have been several formulas derived which express the saturation vapor pressure as a function of temperature. However, the most accurate formulation currently available for the limited range of 0 to 100 °C is that of Wexler, given as

$$e_w(T) = \exp \left\{ \left[\sum_{i=0}^6 C_i (T + 273.15)^{i-2} \right] + D \cdot \ln(T + 273.15) \right\}$$

where

$$\begin{aligned} C_0 &= -2.9912729 \times 10^3 \\ C_1 &= -6.0170128 \times 10^3 \\ C_2 &= 1.887643854 \times 10^1 \\ C_3 &= -2.8354721 \times 10^{-2} \\ C_4 &= 1.7838301 \times 10^{-5} \\ C_5 &= -8.4150417 \times 10^{-10} \\ C_6 &= 4.4412543 \times 10^{-13} \\ D &= 2.858487 \\ T &= \text{temperature of the gas in } ^\circ\text{C}. \end{aligned}$$

Saturation vapor pressures, $e_w(T)$, calculated with this formula are expressed in Pascals. When taking the ratio of $e_w(T_s)$ to $e_w(T_c)$, the units will cancel, leaving the effective degree of saturation as a dimensionless quantity.

1.2.6 Enhancement Factor Ratio

The term $\frac{f_w(P_s, T_s)}{f_w(P_c, T_c)}$, in equation 3 of section 1.2.3, referred to as the "enhancement factor ratio", corrects for the non-ideal behavior of air when it is used as the carrier gas. Note that the individual enhancement factors, f_w , are functions of two independent variables; pressure, P , and temperature, T . Since temperature differences within the system are relatively quite small, and pressure differences relatively large, it is typically the pressure terms, P_c and P_s , which dominate the formulas and bring about the greatest change in the enhancement factor ratio. As applied to the two pressure humidity generator, this enhancement factor ratio may be loosely viewed then as a pressure correction. At a relative humidity of 100%, the pressures P_c and P_s would be equal, causing the enhancement factor ratio to equal 1.0 (ignoring temperature differences), thereby not affecting the relative humidity calculation. Conversely, at low relative humidities (i.e., 5%), where the pressures P_c and P_s differ greatly (i.e., $P_s \approx 20 \cdot P_c$), the enhancement factor ratio may exceed 1.06, affecting relative humidity calculations by 0.3% or more. A formula for calculation of the enhancement factor $f_w(P, T)$ at any given pressure and temperature is given by Greenspan as

$$f_w(P, T) = \exp \left[\alpha \left(1 - \frac{e_w(T)}{P} \right) + \beta \left(\frac{P}{e_w(T)} - 1 \right) \right]$$

where P = the absolute pressure in Pascals, and

$e_w(T)$ = the saturation vapor pressure (in Pascals) at temperature, T .

The two remaining variables, α and β , as derived by Greenspan are given as

$$\alpha = \sum_{i=0}^3 A_i T^i$$

$$\text{and } \beta = \exp \sum_{i=0}^3 B_i T^i$$

where $A_0 = 3.53624 \times 10^{-4}$
 $A_1 = 2.93228 \times 10^{-5}$
 $A_2 = 2.61474 \times 10^{-7}$
 $A_3 = 8.57538 \times 10^{-9}$
 $B_0 = -1.07588 \times 10^1$
 $B_1 = 6.32529 \times 10^{-2}$
 $B_2 = -2.53591 \times 10^{-4}$
 $B_3 = 6.33784 \times 10^{-7}$, and
 T = temperature of the gas in °C.

This formula for the enhancement factor is valid for pressures up to approximately 300 PSIA and over the temperature range of 0 to 100 °C. Therefore it is also valid over the operating range of the humidity generator. Note that to obtain the enhancement factor ratio, the formula must be calculated once at the saturation pressure and temperature, P_s and T_s , and then again at the chamber pressure and temperature, P_c and T_c .

1.3 SPECIFICATIONS

Relative Humidity Range: ----- 10 to 95 %RH
Relative Humidity Resolution: ----- 0.02 %RH
Relative Humidity Uncertainty: @ Pc Tc * ----- 0.5 %RH
Chamber Temperature Range: ----- 0 °C to 70 °C
Chamber Temperature Range: (Optional) ----- -10 °C to 70 °C
Chamber Temperature Resolution: ----- 0.02 °C
Chamber Temperature Uniformity: ** ----- 0.1 °C
Chamber Temperature Uncertainty: ----- 0.06 °C
Chamber Pressure Range: ----- Ambient
Chamber Pressure Uncertainty: * ----- 0.15% FS
Gas Flow Rate Range: *** ----- 5 to 20 L/m
Gas Flow Rate Resolution: ----- 0.02 L/m
Gas Flow Rate Uncertainty: * ----- 2% FS
Gas Type: ----- Air or Nitrogen
Gas Pressure Rating: (MAWP) ----- 175 PSIG
Heating: ----- Stainless Steel Immersion Heater
Heating/Cooling Rate: ----- 2.5 Minutes Per °C Average
Cooling: ----- 1/3 hp R-134A Refrigeration System
Chamber Window: ----- 6" x 6" (152 mm x 152 mm)
Access Port: ----- 1.9" (48 mm) port in right side

Physical Dimensions:

2500 ----- 33" (838 mm) W x 20.25" (514 mm) H x 20" (508 mm) D
2500ST ----- 36" (914 mm) W x 23.25" (591 mm) H x 23" (584 mm) D

Physical Dimensions with cart:

2500 ----- 40" (1.02 m) W x 53.5" (1.36 m) H x 23" (584 mm) D
2500ST ----- 43" (1.09 m) W x 56.5" (1.44 m) H x 26" (660 mm) D

Chamber Dimensions:

2500 ----- 12" (305 mm) W x 12" (305 mm) H x 10" (254 mm) D
2500ST ----- 15" (381 mm) W x 15" (381 mm) H x 12" (305 mm) D

* Represents an expanded uncertainty using a coverage factor, k=2, at an approximate level of confidence of 95%.

** When operating at a test temperature that is within ± 10 °C of the ambient room temperature.

*** Optional 10 to 40 L/m flow rate available.

1.3.1 Facility Requirements

Standard Electrical Power: ----- 100VAC @ 50Hz or 120VAC @ 60Hz, 15 amps
HV Electrical Power (Optional): --- 220VAC @ 50Hz or 240VAC @ 60Hz, 8 amps
Air Supply: ----- Clean, oil free instrument air @ 175 PSIG and 20 L/m

1.3.2 Environmental

Operating Temperature: ----- 15 °C to 30 °C
Storage Temperature: ----- 0 °C to 50 °C
Relative Humidity: ----- 5% to 95 % non-condensing

1.4 COMPUTER CONTROL SYSTEM

1.4.1 General Description

Reference Drawings 91D25903 & 91D25913

The Computer Control System (figure 1-2), consisting of several STD bus plug-in circuit board modules, is embedded in the humidity generator. The computer controls all aspects of the humidity generation process (i.e., controlling temperatures, pressures, etc.) as well as performing all human interface functions of keypad input and information display. The computer also controls printer operation and interfaces with an external computer (optional) for bi-directional RS-232C communications.

The Computer Control System is considered a "single point automation" unit, controlling the functions of the humidity generator to bring it to any one operator input setpoint. The computer will always control the system at the most current setpoint that has been input, either via keypad input, or from external computer input thru the RS-232C port. The Computer Control System knows nothing of past or future setpoints, requiring the use of an external computer if automated temperature / humidity profiling is desired.

The Computer Control System consists of the following key components:

- 1) STD bus computer system, consisting of:
 - a) CPU card with 64180 processor (STD-CPU)
 - b) 8 channel, 15 bit A/D converter board (STD-A/D)
 - c) Memory board (STD-MEM)
 - d) Liquid crystal display driver board (STD-LCD)
 - e) Power supply converter board (STD-PS)
- 2) 256 x 128, backlit, dot matrix Liquid Crystal Display (LCD) module.
- 3) 16 key front panel keypad.

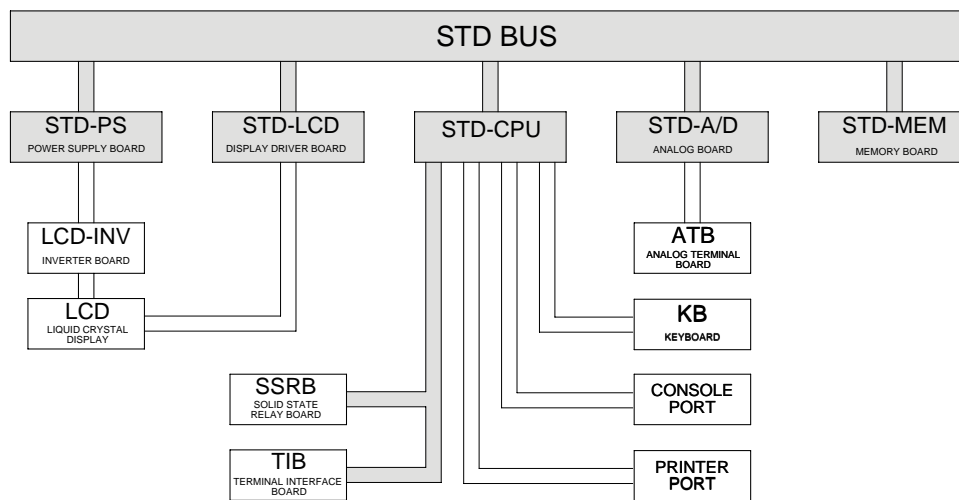

Figure 1-2

1.4.2 Central Processing Unit (STD-CPU)

The Central Processing Unit consists of a 64180 micro-processor, along with all supporting hardware required to interface with the other devices. During the humidity generation process, the main processing unit executes programming designed to control the parameters needed to generate relative humidity, such as pulsing heaters and operating valves. Virtually all functions of the system are controlled by this Central Processing Unit which is responsible for system timing, user interfacing, information display, and parameter control.

1.4.3 Liquid Crystal Display (LCD)

The display incorporated into the 2500 humidity generator is a backlit, 256 x 128, dot matrix Liquid Crystal Display (LCD). It is used for the purpose of displaying system information such as setpoints, measurements, and any other information pertinent to the operation of the 2500 humidity generator.

1.4.4 Liquid Crystal Display Driver (STD-LCD)

The Liquid Crystal Display Driver (STD-LCD) receives display commands and data from the Central Processing Unit then converts these into the signals required to drive the Liquid Crystal Display module. It also incorporates a voltage inversion circuit, which converts +5 VDC input to a -21 VDC output required by the LCD module.

Contrast adjustment is controlled via a 0 to -5 VDC analog output from the STD-CPU. The variable voltage is fed by a single wire from the STD-CPU to the STD-LCD driver board. This voltage level, and the resulting contrast, is adjusted by the user from the front panel keypad. (See section 3.2.2.1)

1.4.5 Keypad

The 4 x 4 Keypad provides operator input to the 2500 humidity generator. The keypad is used to select modes of operation from the menus, enter humidity and temperature points for humidity generation, and perform any other interface functions where user input is required. During operation, most of the screens will show four rectangular shaped blocks at the right side of the display. These blocks correspond with four blank keys on the left side of the keypad, which will be used to perform various functions within the program.

1.4.6 Memory Card (STD-MEM)

The Memory Card contains both EPROM and battery backed memory. This memory contains all program and data required for operation of the generator.

1.4.7 Analog to Digital Converter (STD-A/D)

The Analog to Digital Converter board is a 15 bit analog to digital converter, with integral signal conditioning, used to monitor thermistor resistance, pressure transducer voltage, and flowmeter voltage. It has a useable voltage range of 0 to +5 VDC.

1.5 ELECTRICAL SYSTEM

1.5.1 AC Power Distribution

Reference Drawings 91S25906 thru 91S25912

The 2500 requires a 120 VAC/60Hz or 100 VAC/50Hz, single phase, 15 amp primary power source (240 VAC/60Hz or 220 VAC/50Hz, single phase, 10 amp primary power source for HV power option). From CBS1, primary power is applied to TB1 terminals 1 & 2. From TB1 the primary power is distributed to the 24 VAC step-down transformer (TR1), the refrigeration compressor (C1) through SSR8, the presaturator heaters (H1 & H2) through SSR9, the fluid heater (H3) through SSR10, the fluid pump (FP1) through SSR6, and the console fan (CF1) through SSR7.

1.5.2 Power Supply 24 VAC

Reference Drawing 91S25906

The 24 VAC Step-down Transformer (TR1) provides 24 VAC power for all solenoid valves, as well as power input for the STD Power Supply Card (STD-PS) located in the computer card cage.

1.5.3 Power Supply (STD-PS)

Reference Drawing 91S25906

The Power Supply Card (STD-PS) is a multiple isolated output voltage source providing power to the STD bus computer system, as well as the flow transducer, pressure transducers, solid state relay board (SSRB), terminal interface board (TIB), stepper motor drives (SMD-1 & SMD-2), the liquid level monitor boards (LL1 & LL2), and the LCD backlight inverter circuit.

The Power Supply Card receives power from the 24 VAC step-down transformer (TR1), then rectifies and filters this into +24 VDC unregulated. The unregulated +24 VDC feeds an onboard DC to DC converter which provides the regulated +5 VDC and ± 12 VDC for the STD bus and other equipment. The unregulated +24 VDC also powers the stepper motor drivers (SMD-1 & SMD-2). Note that the +24 VDC Return is electrically isolated from the +5 VDC and ± 12 VDC Common.

Each item listed below utilizes the power from the Power Supply Card (STD-PS) for its particular voltage requirements.

| <u>Voltage</u> | <u>Transducer</u> |
|----------------|---|
| +24 VDC | Stepper motor drivers (SMD-1 & SMD-2) |
| +12 VDC | Mass flow transducer (T1) |
| +12 VDC | 50 PSIA transducer (T2) |
| +12 VDC | 150 PSIA transducer (T3) |
| ± 12 VDC | A/D board (STD-A/D) |
| -12 VDC | LCD backlight |
| +5 VDC | All STD bus cards (STD-CPU,STD-LCD,STD-MEM,STD-A/D) |
| +5 VDC | Solid state relay board (SSRB) |
| +5 VDC | Terminal interface board (TIB) |
| +5 VDC | Liquid level boards (LL1 & LL2) |

1.5.4 Analog Inputs (STD-A/D)

The temperature, flow, and pressure transducers are measured by the Analog to Digital Converter (STD-A/D). Each of these is discussed further in the following sections.

1.5.4.1 Temperature Measurement

Reference Drawing 91S25912

Four 10K Ω thermistors are used for temperature readout and control with continuous real time display by the computer. All are easily removable for calibration.

| | <u>ATB Channel #</u> |
|--|----------------------|
| 1. Saturation Temperature (RTD0) (indication and control) | 0 |
| 2. Presaturation Temperature (RTD1) (indication and control) | 1 |
| 3. Expansion Valve Temperature (RTD2) (indication and control) | 2 |
| 4. Test Chamber Temperature (RTD3) (indication only) | 3 |

The thermistor temperatures are measured by the STD bus Analog to Digital Converter Board (STD-A/D) with a ratio of approximately 0.01 °C/bit. Since the temperatures measured by the STD-A/D board are based on ideal R-T curves, further calibration to actual temperature values is performed by the STD-CPU prior to use or display (refer to 4.2.2 for calibration).

A reference resistor of approximately 10K Ω is connected to channel 4 of the ATB, and is used to compensate for short and long-term drift of the temperature measurement electronics of the STD-A/D circuitry. Deviations from the reference resistor's nominal value are used to mathematically offset the measured values of the four thermistor probes.

1.5.4.2 Mass Flow Transducer (T1)

Reference Drawing 91S25912

The mass flow control system utilizes a thermal type Mass Flow Transducer. Mass flow rates through the generator are manually settable from 2 to 20 L/m by keypad entry. The mass flow rate is displayed on the Liquid Crystal Display (refer to 4.2.5 for calibration).

The flow transducer is powered by +12 VDC from the STD power supply (STD-PS). Transducer output is 0 to 2.5 VDC for a mass flow rate of 0 to 20 L/m. The output voltage is connected to channel 7 of the ATB for measurement by the STD-A/D circuit board.

1.5.4.3 50 PSIA Pressure Transducer (T2)

Reference Drawing 91S25912

The 0-50 PSIA Pressure Transducer is of the piezoresistive type. When saturation pressures are above 50 PSIA this transducer continually monitors chamber pressure. When the saturation pressure is below 50 PSIA it monitors saturation pressure, but switches to chamber pressure (barometric) once every five minutes by pressure select solenoid SOL5. The output voltage is connected to channel 5 of the ATB for measurement by the STD-A/D circuit board. Transducer output is 0 to 5 VDC for 0 to 50 PSIA (refer to 4.2.3 for calibration).

1.5.4.4 150 PSIA Pressure Transducer (T3)

Reference Drawing 91S25912

The 0-150 PSIA Pressure Transducer is of the piezoresistive type. This transducer is used to measure saturation pressures above 50 PSIA. The output voltage is connected to channel 6 of the ATB for measurement by the STD-A/D circuit board. The output of the transducer is 0 to 5 VDC for 0 to 150 PSIA (refer to 4.2.3 for calibration).

1.5.5 Control Logic

All control is performed digitally at a logic level of 5 VDC. Activation of all devices is accomplished by applying a logic low to the control input of the associated solid state relay or other coupling device.

1.5.5.1 Air Supply Solenoid Valve (SOL1)

Reference Drawing 91S25907

The Air Supply Solenoid Valve is activated (air on) by applying a low from the STD-CPU (monitored at TIB terminal C5) to the optical input (-) side of SSR5 on the Solid State Relay Board (SSRB). Valve actuation voltage is 24 VAC.

1.5.5.2 Refrigerant Solenoid Valve (SOL2)

Reference Drawing 91S25907

The Refrigerant Solenoid Valve, when activated, allows refrigerant to be injected into the refrigeration evaporator to remove heat from the heat transfer fluid. This valve is activated by applying a low from the STD-CPU (monitored at TIB terminal C0) to the optical input (-) side of SSR0 on the Solid State Relay Board (SSRB). Evaporator temperature is controlled through fixed frequency pulse width modulation of the refrigerant solenoid valve. Valve actuation voltage is 24 VAC.

1.5.5.3 Pressure Bleed Solenoid Valve (SOL3)

Reference Drawing 91S25907

The Pressure Bleed Solenoid Valve, when deactivated (normally open), vents system pressure during all SHUTDOWN procedures and when electrical power is OFF. This valve is activated by applying a low from the STD-CPU (monitored at TIB terminal C3) to the optical input (-) side of SSR3 on the Solid State Relay Board (SSRB). Valve actuation voltage is 24 VAC.

1.5.5.4 Pressure Select Solenoid Valve (SOL5)

Reference Drawing 91S25907

The Pressure Select Solenoid Valve, when activated, allows the 0-50 PSIA transducer to measure the saturation pressure. This valve is activated by applying a low from the STD-CPU (monitored at TIB terminal C4) to the optical input (-) side of SSR4 on the Solid State Relay Board (SSRB). Valve actuation voltage is 24 VAC.

1.5.5.5 Heat Transfer Fluid Heater (H3)

Reference Drawing 91S25908

The Heat Transfer Fluid Heater is a 500 watt resistive heating element activated by a two stage control process. The heat limit switch (HLS2) must be in the normally closed position, indicating that the fluid temperature is within allowable limits (below 85 °C). Activation is then accomplished by applying a low from TIB channel B5 to the optical input (-) side of SSR10. Heater temperature is controlled through fixed frequency pulse width modulation. Heater voltage is 100/120 VAC (220/240 VAC for HV option).

1.5.5.6 Presaturator Heaters (H1, H2)

Reference Drawing 91S25908

The Presaturator Heaters are resistive heating elements, activated by a two stage control process. The heat limit switch (HLS1) must be in the normally closed position, indicating that the presaturation temperature is within allowable limits (below 95 °C). Activation is then accomplished by applying a low from TIB channel B6 to the optical input (-) side of SSR9. Presaturator heater temperature is controlled through fixed frequency pulse width modulation. Heater voltage is 100/120 VAC and wiring configuration is dependent on the primary power supply. In standard units the heaters are wired in parallel where HV option units have the heaters wired in series.

1.5.5.7 Expansion Valve Heaters (H4, H5)

Reference Drawing 91S25907

The Expansion Valve Heaters, when activated, are used to warm the expansion valve body, offsetting the cooling effects due to gas expansion. The heaters are activated by applying a low from the STD-CPU (monitored at TIB terminal C1) to the optical input (-) side of SSR1 on the Solid State Relay Board (SSRB). Heater temperature is controlled through fixed frequency pulse width modulation. Heater voltage is 24 VAC.

1.5.5.8 Fluid Circulation Pump (FP1)

Reference Drawing 91S25907

The Fluid Circulation Pump is a magnetically coupled pump energized by applying a low from the STD-CPU (monitored at TIB terminal C6) to the optical input (-) side of relay SSR6 on the Solid State Relay Board (SSRB). Pump voltage is 100/120 VAC (220/240 VAC for HV option).

1.5.5.9 Refrigeration Compressor (C1)

Reference Drawing 91S25908

The Refrigeration Compressor is energized by applying a low from TIB channel B4 to the optical input (-) side of SSR8. Compressor voltage is 100/120 VAC (220/240 VAC for HV option).

1.5.5.10 Flow Valve (V1) – Actuation

Reference Drawing 91S25910

The Flow Valve is used to control system mass flow rate and is driven indirectly via pulses from the Terminal Interface Board (TIB) channels B1 & B3, which trigger stepper motor driver SMD-1. Pulses on channel B1 close the valve, while pulses on channel B3 open the valve. The stepper motor driver is powered from the unregulated 24 VDC output of the STD-PS circuit board in the STD card cage. The HOME or FULLY CLOSED position is sensed by a low at TIB channel A1 resulting from the contact closure of limit switch SL-1.

1.5.5.11 Expansion Valve (V2) – Actuation

Reference Drawing 91S25911

The Expansion Valve is used to control saturation pressure and is driven indirectly via pulses from the Terminal Interface Board (TIB) channels B0 & B2, which trigger stepper motor driver SMD-2. Pulses on channel B0 will close the Expansion Valve, while pulses on channel B2 will open the Expansion Valve.

The stepper motor driver is powered from the unregulated 24 VDC output of the STD-PS circuit board. The HOME or FULLY CLOSED position is sensed by a low at TIB channel A0 resulting from the contact closure of limit switch SL-2.

1.5.5.12 Reservoir Liquid Level Transducer (LL1)

Reference Drawing 91S25910

The Reservoir Liquid Level Transducer monitors reservoir water level, which is displayed on the computer screen. A voltage corresponding to the reservoir water level is output from LL1 to the STD-CPU via TB2-9. When an empty indication occurs during RH generation an audible alarm will sound accompanied by a warning message. An empty reservoir during start up forces a shutdown, accompanied by both audible and visual alarms. The liquid level board is powered from +5 VDC.

1.5.5.13 Presaturator Liquid Level Transducer (LL2)

Reference Drawings 91S25907 and 91S25910

The Presaturator Liquid Level Transducer is used in maintaining the presaturator distilled water level constant. When the water level drops below the control point, the sensor pulls channel A2 of TIB low, informing the CPU of the condition. The CPU will then activate solenoid SOL4, allowing distilled water into the presaturator until LL2 puts a high on channel A2 signifying a full or filled condition.

SOL4 is activated by applying a low from the STD-CPU (monitored at TIB terminal C2) to the optical input (-) side of SSR2 on the Solid State Relay Board (SSRB). If the presaturator does not fill to the control point (i.e., reservoir empty) within approximately 5 minutes, the system will shut down. The liquid level board is powered from +5 VDC.

1.5.5.14 Console Fan (CF1)

Reference Drawing 91S25907

The Console Fan is energized by applying a low from the STD-CPU (monitored at TIB terminal C7) to the optical input (-) side of solid state relay SSR7 on the Solid State Relay Board (SSRB). The fan is activated when the CPU senses a cabinet temperature above 30 °C or when control is enabled (reference section 3.2.5). Fan voltage is 100/120 VAC (220/240 VAC for HV option).

1.6 PNEUMATIC SYSTEM

1.6.1 General Description

Reference Drawing 91S25916

The 2500's pneumatic system (figure 1-3) requires an air supply that is clean and oil free, and should be capable of supplying a maximum pressure of 175 PSIG at a flow rate of 20 L/m. An air supply filtered to a particle size of 0.5 microns or less, a hydrocarbon content of 1 PPM or less, with a pressure dewpoint no greater than 10 °C is recommended. The air supply is connected to a 1/4" FPT fitting located at the lower rear of the console. From this point, the airstream is admitted through the air on/off solenoid valve (SOL1) to the console air supply regulator (REG). After regulation, the airstream passes through the mass flow meter (T1) to the computer controlled mass flow valve (V1). Mass flow rates are user settable and displayed on the Liquid Crystal Display.

From the flow control valve, the air flows to the presaturator (PSAT) (refer to 1.6.2). The presaturator water temperature is maintained at a temperature approximately 15 to 20 °C warmer than the saturation temperature so as to humidify the airstream to a water vapor content greater than saturation. The presaturated air then exits the presaturator and enters the saturator (SAT) (refer to 1.6.3). As the air flows through the saturator, excess water vapor is condensed as the airstream is cooled to saturation temperature, achieving 100% saturation. Saturation pressure is measured as the air exits the saturator and flows to the expansion valve (V2) (refer to 1.6.4).

The computer controlled expansion valve allows the saturated high pressure airstream to be reduced to chamber pressure by varying the orifice from nearly closed to fully open depending upon the required saturation pressure. After expansion, the air flows into the test chamber at the desired relative humidity conditions. The airstream exits the test chamber through the chamber exhaust port, located at the bottom rear of the test chamber (if the access port is sealed).

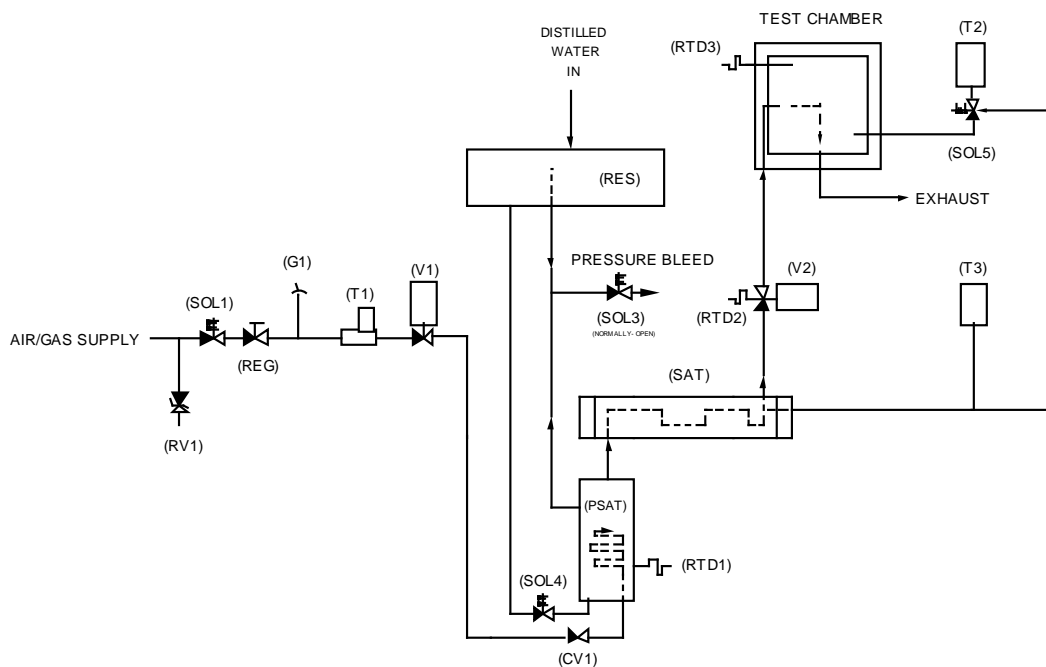

Figure 1-3

1.6.2 Presaturator

The airstream of a two-pressure generator must be 100% saturated with water vapor at test temperature on the high-pressure (saturator) side of the expansion valve. This is accomplished by first passing the airstream through a "presaturator" (PSAT). The presaturator is a vertical pressure vessel presenting a water surface to the incoming airstream and is maintained constant at a temperature 15 to 20 °C warmer than the desired system (chamber) temperature. After presaturation, the air exits the top of the presaturator and is directed to the saturator.

Presaturation temperature, sensed by a 10K Ω thermistor, is adjustable and controllable from 20 to 90 °C. Heating of the presaturator is provided by two 250-watt stainless steel immersion type heaters, powered through a solid state relay (SSR9).

The presaturator water level is maintained automatically via computer control of the presaturator liquid level control solenoid valve (SOL4). This valve controls the flow of distilled water from the supply reservoir (RES) (refer to 1.6.5) to the presaturator, maintaining the level constant to within approximately 1/16 inch (1 oz.).

1.6.3 Saturator

Saturation of the airstream to 100% relative humidity, upstream of the expansion valve, is accomplished in a "tube in shell" type heat exchanger referred to as the "saturator". The humidified airstream from the presaturator, humidified to an absolute moisture content greater than saturation at final saturation temperature, flows through the saturator. Excess water vapor is condensed from the airstream as it establishes equilibrium with the heat transfer fluid, ensuring that the airstream has a value of 100% relative humidity at fluid (saturation) temperature. The saturation pressure is monitored as the airstream exits the saturator. This measurement is used in the calculation and control of the desired relative humidity.

1.6.4 Expansion Valve

After exiting the saturator, the 100% saturated high-pressure airstream is reduced to chamber pressure through the "expansion valve". The expansion valve (V2) is an electro-mechanically actuated valve, controlled from the computer, using feedback from the saturator and chamber pressure measurements. This valve is heated and thermally insulated to maintain the valve body above the dewpoint of the adiabatically cooled airstream.

1.6.5 Reservoir

The reservoir is a pressure vessel, constructed of 300 series stainless steel, and holds a one gallon supply of distilled water for the presaturator. This vessel is maintained at system pressure and, upon demand, allows reserve distilled water to flow freely to the presaturator. If a low level reservoir water condition is sensed during operation of the humidity generator, a warning message will begin flashing on the display, accompanied by an audible warning beep.

A one gallon supply of distilled water may last from 12 hours to 9 months of continuous operation, depending on the temperature and RH being generated. High temperatures and high humidities require large amounts of water, while low temperatures and low humidities require very small amounts of water. See section 3.2.8 for reservoir filling procedure.

While not exact, the following simple formulas may be used to approximate continuous run time at specific RH and temperature values.

$$\text{Hours per gallon @ } 0 \text{ }^{\circ}\text{C, } 20 \text{ L/m} \approx \frac{68000}{\%RH}$$

$$\text{Hours per gallon @ } 25 \text{ }^{\circ}\text{C, } 20 \text{ L/m} \approx \frac{14000}{\%RH}$$

$$\text{Hours per gallon @ } 50 \text{ }^{\circ}\text{C, } 20 \text{ L/m} \approx \frac{3500}{\%RH}$$

$$\text{Hours per gallon @ } 70 \text{ }^{\circ}\text{C, } 20 \text{ L/m} \approx \frac{1200}{\%RH}$$

Using lower flow rates will increase the "hours per gallon" time directly. For instance, a 2:1 decrease in flow (i.e., 10 L/m) causes a corresponding 2:1 increase in time.

1.7 HEAT TRANSFER FLUID SYSTEM

1.7.1 General Description

Reference Drawing 91S25917

The Model 2500 Benchtop Humidity Generator incorporates a unique test chamber, in that it has a fluid shell surrounding the test space (figure 1-4). Temperature controlled fluid, consisting of approximately 30-40% water and 60-70% propylene glycol, is circulated at a rate of nearly 10 gallons per minute through the fluid shell by a magnetically coupled centrifugal pump (FP1). The fluid mass and fast circulation rate result in inherent temperature stability allowing a very stable and precise humidity to be generated. The chamber interior and fluid shell are constructed of 300 series stainless steel assuring rustproof quality. All seams are heliarc welded for hermetic sealing of the liner and shell.

In this closed loop, non-pressurized system, conditioned fluid flows from the pump outlet to the saturation temperature/control sensor (RTD0). From this point, the fluid circuit splits; one path flowing through the test chamber fluid shell and the other path flowing through the saturator assembly:

- Path 1) Temperature conditioned heat transfer fluid flows through the test chamber fluid shell, exits at the upper left of the fluid shell and enters the refrigeration evaporator (EX1). The refrigeration evaporator is a single pass, tube in shell type, heat exchanger allowing fluid cooling. After cooling, fluid enters the immersion heater housing, flows over the immersion heater (H3), and exits to the circulation pump intake, completing the chamber fluid circuit.
- Path 2) Temperature conditioned heat transfer fluid enters the saturator assembly (SAT) at the opposite end from the airstream and flows through the saturator to the expansion tank (located on top of the test chamber). The saturator fluid circuit then merges with the chamber fluid circuit at the exit of the chamber fluid shell.

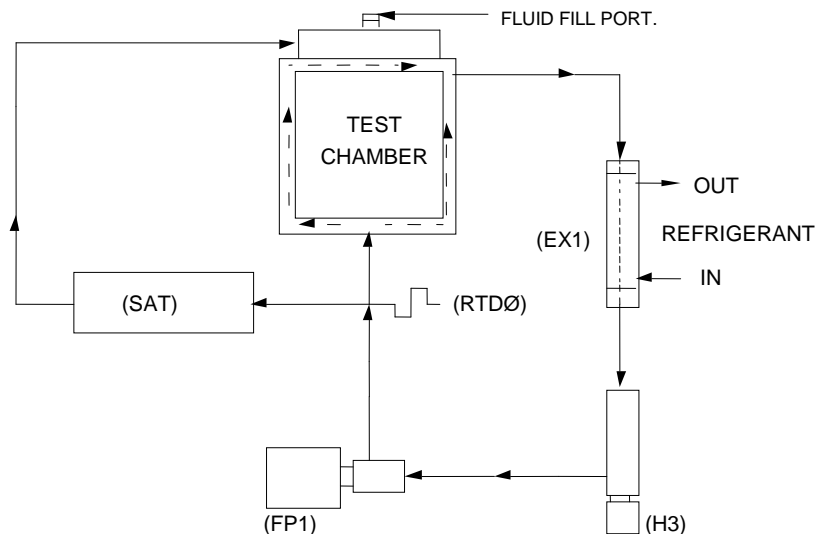

Figure 1-4

1.7.2 Fluid Heating

Reference Drawing 91S25917

The 2500's heat transfer fluid is heated by a 500 watt immersion heater (H3) (figure 1-4). The immersion heater is installed into a copper heater housing and is located in the main fluid path between the refrigeration evaporator (EX1) and circulation pump (FP1). Primary power to the immersion heater is switched by a solid state relay (SSR10). Pulsed power to the immersion heater is controlled by the computer, using feedback from the fluid control (saturation temperature) sensor (RTD0). High temperature disconnect of the immersion heater is provided for by a bi-metal temperature sensing element, (HLS2) operating single pole contacts that disconnect the primary power.

1.7.3 Fluid Refrigeration

Reference Drawing 91S25918

The heat transfer fluid of the 2500 is cooled by an R-134A refrigeration system (figure 1-5). The refrigerant is compressed from a low-pressure vapor into a heat laden high-pressure vapor by the refrigeration compressor (C1). High-pressure vapor flows to the air-cooled condenser (CON) where it is cooled to a high-pressure liquid as heat is removed. Condensed refrigerant then flows through the filter-drier (F2) and passes to the refrigerant solenoid valve (SOL2). Primary power to the refrigerant solenoid valve is switched by a solid state relay (SSR0). Pulsed power to the refrigerant valve is controlled by the computer, using feedback from the fluid control (saturation temperature) sensor (RTD0).

Upon demand from the computer, refrigerant is pulsed to the thermostatic expansion valve (V3), and metered into the refrigerant evaporator (EX1). The refrigerant expands, changes to a low-pressure vapor as it absorbs heat, and the heat laden vapor is then piped to the suction side of the compressor and the cycle is repeated. Liquid refrigerant also flows to a small thermostatic expansion valve (V4), which, depending upon suction line temperature, meters small amounts of refrigerant into the suction side of the refrigeration compressor during stand-by or hot-gas bypass (V5) modes. This allows the compressor to operate under a no-load condition until a cooling demand is sent to the refrigerant solenoid, allowing for continuous operation, eliminating repeated on/off cycling. During times of high heat demand, such as a temperature setpoint change (i.e., 25 °C to 50 °C), the refrigeration compressor will automatically shut down until such time as cooling is again demanded. Once started, the compressor will then remain on as cooling is continuously required to hold the heat transfer fluid at setpoint temperature.

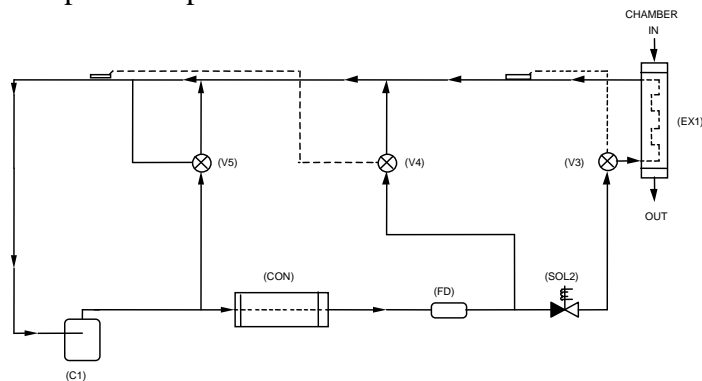

Figure 1-5

Section 2

INSTALLATION

2.1 GENERAL

Preparations should be made to have adequate bench or floor space and a source of primary power available at the location of use. A clean oil free instrument quality air supply must also be available if the generator is installed without the cart air supply.

2.2 FACILITIES REQUIRED

Reference Drawing 91D25901

2.2.1 Bench / Floor Space

A bench and/or floor, capable of supporting approximately 300 pounds, with a minimum space of 24" (610mm) deep x 40" (1.02m) wide is recommended and 27" (686mm) deep x 43" (1.09m) wide for 2500ST(drawing 91D25901). Allow an additional 20" (508mm) in width for clearance, if possible, so as to allow complete opening of the chamber door and access to the test port.

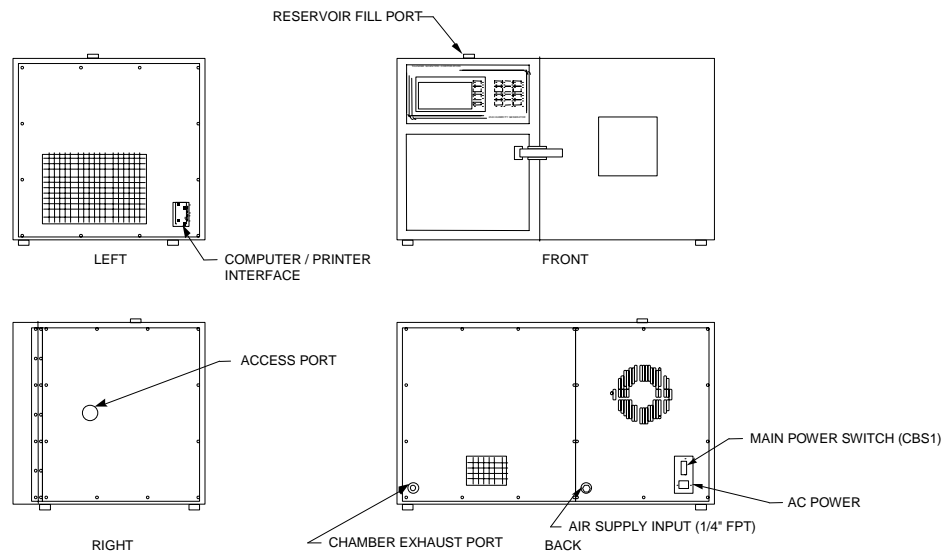

Figure 2-1

2.2.2 Power

The 2500 humidity generator requires a primary power source of 120 VAC/60Hz or 100 VAC/50 Hz at 15 amps minimum (240 VAC/60 Hz or 220 VAC/50 Hz at 10 amps minimum for HV option). The pneumatic cart with it's 1/2 horsepower air compressor requires an additional power source of 120 VAC/60 Hz or 100 VAC/50 Hz at 8 amps minimum (240 VAC/60Hz or 220 VAC/50 Hz at 5 amps minimum for HV option).

2.2.3 Air Supply (if used without pneumatic cart)

The 2500's pneumatic system requires an air supply that is clean and oil free. If the generator is to be used without the pneumatic cart, instrument air at a maximum pressure of 175 PSIG and capable of a flow rate of at least 20 l/m is recommended. The air supply should be filtered to a particle size of 0.5 microns or less, a hydrocarbon content of 1 PPM or less, with a pressure dewpoint of 15 °C or less.

2.2.4 Distilled Water Supply

The 2500 humidity generator requires one gallon (3.8 liters) of double distilled water per fill. A one gallon supply can last from 12 hours to as many as 6800 hours of continuous use depending upon the temperature and humidity at which the generator is operated (reference section 1.6.5). During operation near ambient temperature and 50% RH, one gallon should last for approximately 290 hours.

2.3 PREPARATION

2.3.1 Chamber Fluid Filling

Reference Fig 2-2 and Drawings 97D25924 & 91S25917

Temperature conditioning of the 2500 test chamber utilizes a 60-70% mixture of propylene glycol and 30-40% water as the heat transfer fluid. This fluid is circulated by a magnetically coupled centrifugal pump through the refrigeration and heating system and the fluid shell surrounding the test chamber.

2.3.1.1 Chamber Fluid Filling Procedure

Chamber fluid filling requires:

T10 Torx Driver (supplied)

Chamber fill funnel (insert into the 5/8" (15.9mm) diameter opening) (supplied)

3 US gallons (11.35 liters) of -100 °C propylene glycol mix (4 US gallons (15.14 liters) for 2500ST) (supplied)

To fill chamber fluid jacket proceed as follows:

- 1) Remove top right console panel (panel above chamber).
- 2) Locate fluid fill port (under insulation and labeled "Fluid Fill Port").
- 3) Remove "Red" cap and insert the chamber fill funnel into fluid fill port.
- 4) Using 3 U.S. gallons of -100 °C propylene glycol mix (4 U.S. gallons for 2500ST), **fill until level is approximately 1/4" (6.35 mm) below the bottom of the fill port. Note: the fluid should touch the base of the funnel.**
- 5) Remove funnel and replace fluid fill port cap and insulation.
- 6) Replace top right console panel.
- 7) Chamber fluid filling is now complete.

See figure 2-2

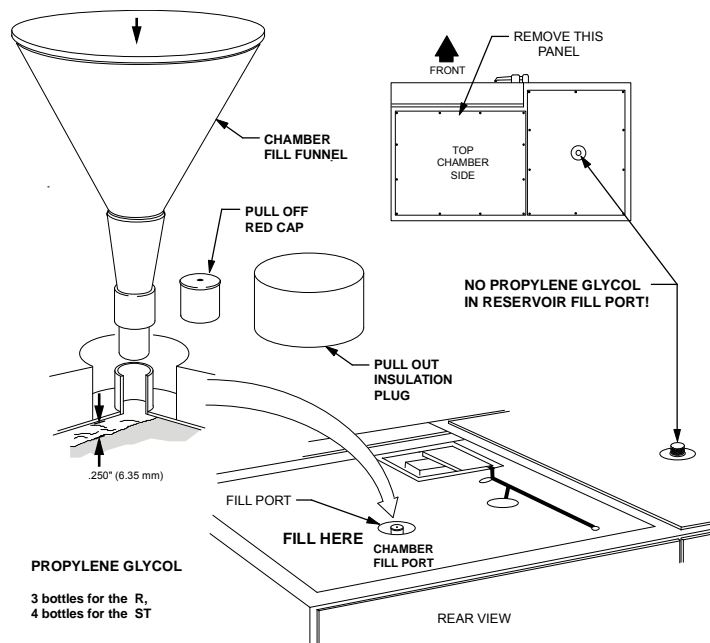

Figure 2-2

2.3.2 Positioning & Connections

Reference Drawings 91D25901, 09S25920, 91S25921, 98D25919 & 98D25925

2.3.2.1 Pneumatic Cart

Position the 2500 humidity generator on the cart (figure 2-3 & 2-4), with the cart push bar on the left side of the generator, placing the leveling feet within the circular cutouts. Connect the short air supply hose to the generator air supply inlet.

STANDARD COMPRESSOR

Remove the air compressor shipping strap. For operation, place the air compressor on the floor and connect the 25 foot (7.62m) air supply hose between the air compressor outlet and the cart air supply inlet.

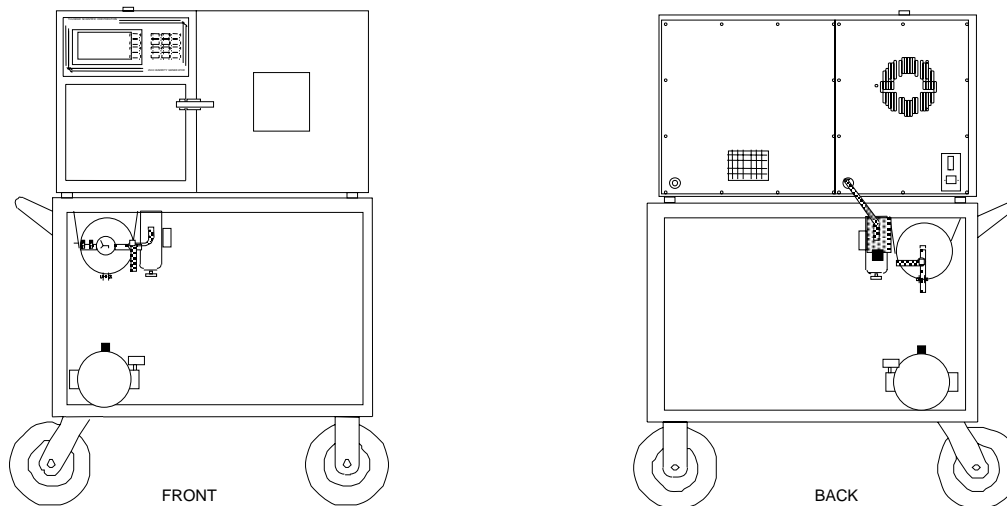

Figure 2-3

SOUND ENCLOSED COMPRESSOR (Optional)

Remove the sound enclosed air compressor shipping strap. For operation, the sound enclosed air compressor may be left on the cart and connected to the cart air supply inlet with the short air hose attached to it or may be set on the floor and connected using the 25 foot (7.62m) air supply hose between the sound enclosed air compressor outlet hose and the cart air supply inlet.

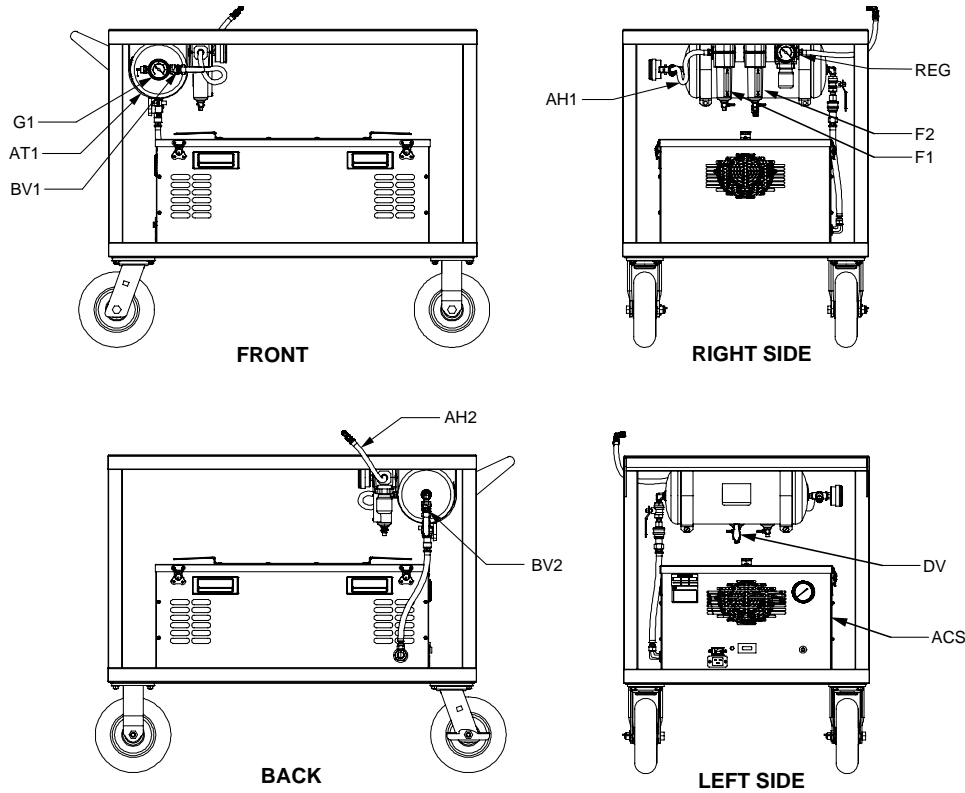

Figure 2-4

2.3.2.2 Bench Space

Position the 2500 humidity generator allowing at least 4 inches (102mm) of space near console air intake (left side), and 4 inches (102mm) at the rear of the console for the exhaust fan. Allow as much space as possible on the right side so as to allow clearance for utilizing the chamber access port and to allow for opening of the chamber door. Level the console using the top as a reference. Tighten leveling leg locking nuts against frame.

2.3.2.3 Power

Be sure the main console Power switch is OFF, then plug the 2500 into a source of 120 VAC/60Hz or 100 VAC/50 Hz at 15 amps minimum (240 VAC/60 Hz or 220 VAC/50 Hz at 10 amps minimum for HV option). If using the pneumatic cart, plug the air compressor into a source of switched 120 VAC/60Hz or 100 VAC/50 Hz at 8 amps minimum (240 VAC/60 Hz or 220 VAC/50 Hz at 5 amps minimum for HV option).

2.3.2.4 Air Supply

Using a line size equal to or larger than 1/4" (6.35mm) OD, connect a source of clean, oil free, instrument quality air (refer to 2.2.3) to the 1/4" FPT fitting located at the lower rear of the console (working pressure is 175 PSIG). If the generator is installed on the pneumatic cart, but an alternate air supply (facility) is desired, connect the alternate air supply (175 PSIG MAWP) to the air inlet of the cart air supply so as to utilize the valves, storage tank, filter, and 150 PSIG regulated output of the pneumatic cart (figure 2-5).

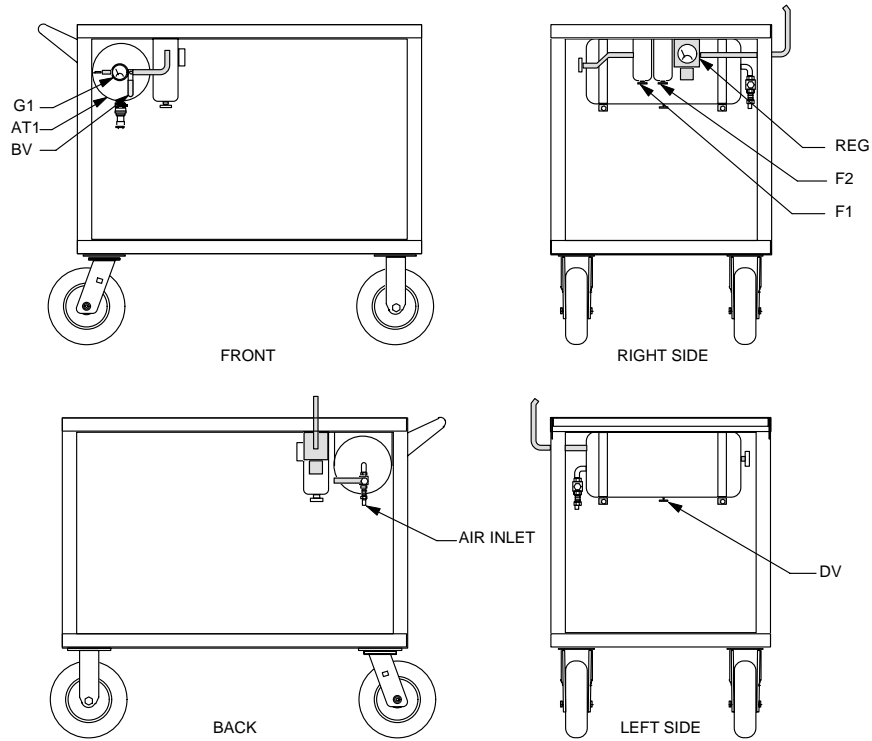

Figure 2-5

OPERATION

3.1 GENERAL

At this point, all positioning and preparation of the Series 2500 humidity generator should have been performed.

3.2 STANDARD OPERATING PROCEDURES

3.2.1 Power-Up

- A) Verify that the air supply connection has been made, that power has been applied to the air compressor, and that the air supply is pressurized. Open the On/Off valves, if installed, in this supply line.
- B) Verify that primary AC power is connected to the console and is switched ON.
- C) Toggle the Power switch located at the lower right rear of console to ON. The liquid crystal display will light, a banner will appear, and the generator will perform a very short diagnostics test.

3.2.2 Control/Display Screen

At the end of the power-up sequence, the following Control/Display Screen appears.

| | | SetPnt | Actual | |
|-------|-------|--------|---------|--------------|
| %RH | @Pc | 50.25 | | CHNG SETP |
| *%RH | @PcTc | 50.00 | | CHNG UNIT |
| SATUR | Psi | 29.40 | | EDIT /CAL |
| CHMBR | Psi | | | RUN |
| SATUR | °C | 25.00 | | |
| CHMBR | °C | | | |
| FLOW | l/m | 20.00 | | |
| | | | EWWWLIF | |

All control and measurement parameters critical to the operation of the humidity generator are displayed on this screen. Notice that in the left most column, each parameter is identified with a brief title and corresponding units. The generator operates in a variety of temperature, pressure, and flow units (section 3.2.4). Humidity is calculated and displayed in percent Relative Humidity (%RH). The asterisk in the left most column indicates the active humidity control parameter (section 3.2.5). The reservoir fluid level is graphically indicated and continually updated in the lower right hand corner (section 3.2.9).

The "SetPnt" column lists control setpoints used as a target value in order to control these parameters. Only those parameters which the generator directly controls have values listed in this column. For instance, since the 2500 has no control over the chamber pressure, that parameter has no value listed in the "SetPnt" column.

The "Actual" column lists all of the measured data and calculated parameters of the generator.

A description of each of the Control/Display parameters follows:

%RH @Pc - The %RH calculated at the chamber pressure Pc. This calculation ignores the chamber temperature and Effective Degree of Saturation (section 1.2.5), and assumes that the chamber is at saturation temperature. The humidity %RH @ Pc is calculated from the Pressure Ratio (section 1.2.4) and Enhancement Factor Ratio (section 1.2.6), resulting in

$$\%RH @ P_c = \frac{P_c}{P_s} \cdot \frac{f_{P_s, T_s}}{f_{P_c, T_s}} \cdot 100$$

Note that the enhancement factor for the chamber (the numerator of the Enhancement Factor Ratio) is calculated using saturation temperature rather than chamber temperature.

%RH @ PcTc - The %RH calculated at the chamber pressure Pc and chamber temperature Tc relative to saturation temperature Ts. This is the most accurate calculation of %RH at the point in the immediate vicinity of the chamber temperature probe. Placing the chamber temperature probe at the humidity sensing point of devices under test gives the actual value of the relative humidity being imposed on the devices, as it is dependent on both pressure and temperature.

Viewing the difference between %RH @Pc and %RH @PcTc gives a good indication of the gradient which exists between the humidity at the walls of the chamber (since they are at saturation temperature) and the humidity at the chamber temperature probe. The humidity %RH @PcTc is calculated from the formula

$$\%RH @P_c T_c = \frac{P_c}{P_s} \cdot \frac{f_{P_s, T_s}}{f_{P_c, T_c}} \cdot \frac{e_s}{e_c} \cdot 100$$

Note that this formulation utilizes the Pressure Ratio (section 1.2.4), the Effective Degree of Saturation (section 1.2.5), and the Enhancement Factor Ratio (section 1.2.6) found in equation 3 of section 1.2.3. Note also that the enhancement factor for the chamber (the numerator of the Enhancement Factor Ratio) is calculated using chamber temperature.

SATUR xxx - The saturation pressure measurement, Ps, may be displayed in units of bar, mb, Tor, kPa, "Hg, or psi. Various humidity values are generated by controlling the saturation pressure.

CHMBR xxx - The chamber pressure measurement, Pc, may be displayed in units of bar, mb, Tor, kPa, "Hg, or psi. The chamber is designed to operate at ambient barometric pressure only.

- SATUR °X - The temperature of saturation, Ts, as measured by the saturation fluid temperature probe. Saturation temperature is used in the calculation of %RH @PcTc, and is used to control the temperature of the fluid surrounding the saturator and chamber. Temperatures may be displayed in °C or °F.
- CHMBR °X - The temperature of the chamber, Tc, as measured by the chamber temperature probe. Chamber temperature is used in the calculation of %RH @PcTc. The chamber temperature probe should be placed as close as practicable to the humidity sensing element of any device under test. Chamber temperature typically lags behind the saturation temperature during excursions away from ambient. Temperatures may be displayed in °C or °F.
- FLOW xxx - The mass flow rate displayed in units of l/m, l/h, cfm, or cfh. This parameter is not used in the calculation of humidity and is only an indication of the amount of gas flowing through the system. This parameter is used when performing tests on flow sensitive humidity measurement devices such as aspirated psychrometers, chilled mirrors, etc.

3.2.2.1 Changing the Display Contrast

To increase the display contrast, press the <1> key repeatedly on the numeric keypad. To decrease the contrast, press the <0> repeatedly. The new contrast setting is automatically remembered by the system.

3.2.3 Changing Setpoints

After the initial power-up sequence of section 3.2.1, the Control/Display screen appears. At the right of the display are 4 rectangular function key menu options. These labels correspond to the four blank keys on the left side of the numeric keypad.

To change any of the RH, pressure, temperature, or flow setpoints, press the [CHNG SETP] key. The menu labels then change to arrows.

| | | SetPnt | Actual | |
|-------|-------|--------|----------|---|
| %RH | @Pc | 50.25 | | ▲ |
| *%RH | @PcTc | 50.00 | | ▼ |
| SATUR | Psi | 29.40 | | ◀ |
| CHMBR | Psi | | | |
| SATUR | °C | 25.00 | | |
| CHMBR | °C | | | |
| FLOW | l/m | 20.00 | | ▶ |
| | | | EWLWLLIF | |

A cursor block will begin flashing in the "SetPnt" column on the first digit of the current humidity control parameter (the one with the asterisk to the left). Move the cursor up, down, left, or right using the appropriate arrow key.

To change any (or all) of the setpoints, position the cursor over the desired setpoint, then edit the value using the numeric keypad. Continue using the arrow keys and the numeric keypad until all desired values have been changed.

End the setpoint editing session by pressing the <ENTER> key on the numeric keypad. The arrow keys revert back to their previously displayed functions, and the setpoints are validated and updated.

Example: Change the setpoints to 30%RH @PcTc at a temperature of 22.00 °C (or 71.60 °F)

- A) Press [CHNG SETP]. The key labels change to arrows, and the cursor begins flashing.
- B) Using the arrow keys and numeric keys as necessary, make the %RH @PcTc setpoint value on the screen appear as "30.00".
- C) Move the cursor down to the SATUR °X setpoint value. System (chamber) temperature is always changed from this saturation temperature setpoint.
- D) Using the arrows and numeric keys as necessary, make the SATUR °X setpoint value appear as "22.00" if the system is in °C or "71.60" if the system is in °F.

Note: To enter a negative temperature on systems equipped with this option, press the left arrow key until the negative sign appears, then enter the desired temperature.

- E) Find the asterisk in the left most column of the display. If it is not next to the %RH @PcTc label, use the arrow keys and position the cursor back at the %RH @PcTc setpoint value. This indicates the humidity parameter used as the active control setpoint (see section 3.2.5).
- F) Press the <ENTER> key. The cursor disappears, and the displayed labels revert back to their previous descriptions. There should also be an asterisk left of the %RH @PcTc line label.

Setpoints within legal limits are accepted. Those setpoints which are slightly above or below these limits are simply replaced by the appropriate limit value. Those setpoints which are far beyond the limits revert back to the previous setpoint value and are accompanied by a short audible warning beep. This most often occurs when the user inadvertently enters a wrong value, or fails to include a decimal point.

Note: Always take note of the units when changing setpoints. All setpoints must be entered in the units currently displayed on the screen.

3.2.4 Changing Units

The generator can operate in a variety of user selectable pressure, temperature, and flow units.

To change units from the main control screen:

A) Press the [CHNG UNIT] key. The menu labels change to indicate the currently selected pressure, temperature, and flow units.

| | | SetPnt | Actual | |
|-------|-------|--------|----------|-------------|
| %RH | @Pc | 50.25 | | |
| *%RH | @PcTc | 50.00 | | |
| SATUR | Psi | 29.40 | | PRES Psi |
| CHMBR | Psi | | | |
| SATUR | °C | 25.00 | | TEMP °C |
| CHMBR | °C | | | |
| FLOW | l/m | 20.00 | | FLOW l/m |
| | | | EWUUUUUF | |

B) Press [PRES] to select from psi (pounds per square inch), "Hg (inches of mercury), Torr (Torr), bar (bars), mbar (millibars), and kPa (kilopascals) units of pressure.

C) Press [TEMP] to select from °C (degrees centigrade) and °F (degrees fahrenheit) units of temperature.

D) Press [FLOW] to select from l/m (liters per minute), l/h (liters per hour), cfm (cubic feet per minute), and cfh (cubic feet per hour) units of flow.

E) Press <ENTER> to return to the main control screen.

3.2.5 Control Modes

The generator has the ability to control the humidity in one of three possible modes.

Mode 1) %RH @Pc is held constant even under varying conditions of saturation and chamber temperature. The saturation pressure tracks at a fixed ratio above the chamber pressure. %RH @PcTc and SATUR xxx setpoints vary under computer control.

Mode 2) %RH @PcTc is held constant by varying saturation pressure to compensate for changes in chamber (barometric) pressure, and differences between the saturation and chamber temperatures. This is considered to be the most accurate RH calculation. %RH @Pc and SATUR xxx setpoints vary under computer control.

Mode 3) SATUR xxx (saturation pressure) is controlled at a constant value independent of chamber pressure, chamber temperature, or saturation temperature. %RH @Pc and %RH @PcTc setpoints vary under computer control.

The active control mode setpoint remains constant, while the two inactive mode setpoints vary under computer control with changes in measured temperatures and pressures.

Mode 2 (%RH @PcTc) is the most often used and is the power-up default mode of the generator. The currently active mode is indicated on the display by an asterisk to the left of the parameter. Also, when a setpoint change is initiated, the cursor always begins flashing on the current control mode parameter.

To change the control mode:

- A) Press [CHNG SETP] to enter the setpoint editing mode.
- B) Position the cursor on the desired control parameter.
- C) Change its value if needed.
- D) With the cursor still on that parameter, press <ENTER>. The asterisk will then appear next to the selected control mode parameter.

Any time that a setpoint editing session is terminated (by pressing <ENTER>), AND the cursor is on one of the three control mode parameters, that control mode becomes active. If the cursor is on a non-control mode parameter (i.e., FLOW xxx, SATUR °X, etc.), the current control mode remains in effect. An altered setpoint for a non-active control parameter that is not made the active control mode will not remain as a valid setpoint.

3.2.6 Run/Stop

When the [RUN] key is pressed, the temperature, pressure, and flow control processes begin. The fluid circulation pump will start and if the system requires cooling, the refrigeration compressor will energize. The [RUN] key then toggles to [STOP].

The 2500 will generate the values of humidity, temperature, and flow indicated in the "SetPnt" column. Setpoints and units may be freely changed regardless of whether the generator is RUNNING or STOPPED (reference section 3.2.3/3.2.4). The values in the "Actual" column are the actual measured values, and begin updating every 1.5 seconds.

| | | SetPnt | Actual | |
|----------|----------|--------|---------|--------------|
| %RH | @Pc | 50.25 | 50.26 | CHNG SETP |
| *%RH | @PcTc | 50.00 | 50.01 | |
| SATUR | Psi | 24.23 | 24.20 | CHNG UNIT |
| CHMBR | Psi | | 12.11 | |
| SATUR | °C | 25.00 | 25.00 | PRNT OFF |
| CHMBR | °C | | 25.13 | |
| FLOW | l/m | 20.00 | 19.74 | STOP |
| 08/10/12 | 12:40:04 | | ■■■■■■■ | |

Pressing [STOP] causes the computer to perform a system shutdown and consists of the following actions:

- a) Pressure bleed solenoid valve opens.
- b) Fluid circulation pump and refrigeration compressor stop.
- c) Flow and Expansion valves close.
- d) All control is disabled.

Once shutdown is completed the generator is left in an idle mode.

3.2.7 Printer (optional)

Reference Drawing 91D25915

An optional printer is used for hardcopy output of system data and other parameters. While the 2500 humidity generator is operating, data is output on a timed interval basis when activated by the user. User alterable printer parameters are explained in section 3.3.2.6. The printer is connected using either a factory supplied or user made cable. Data will be printed in the currently selected units.

The [PRNT OFF] key, when pressed, toggles to [PRNT ON] and causes measured system data to be sent to the printer at regular time intervals (see section 3.3 to change default time and other print parameters).

The [PRNT ON] key, when pressed, toggles to [PRNT OFF], disables printer output, and sends a form feed command to the printer.

The <•> key, when pressed, immediately sends one line of system data to the printer regardless of the PRNT ON/OFF status, and independent of print time interval.

Using this same procedure with a PC connected to the printer port instead of a printer, data can be stored on the PC in a text file for later manipulation and printing. For instructions on how to connect and use this option, refer to Section 4.2.5.

3.2.8 Power-Off

Power-Off refers to actually removing power and/or utilities from all or part of the humidity generator. Before disconnecting primary power, a shutdown should be performed. If the generator is currently RUNNING, press the [STOP] key.

If the generator is run on a daily basis, the system may be left idle with the power switch ON so as to maintain the electronics at approximate operating temperature. If complete system shutdown is to be performed, press the main rear panel Power switch to OFF. All functions of the 2500 generator will shut off.

3.2.8.1 Maintenance Power-Off

Before maintenance of any kind, other than calibration, the following must first be performed:

- A) Press [STOP], if system is currently RUNNING, to close all valves and disable control.
- B) Press main rear panel Power switch to OFF.
- C) Disconnect console from primary power.
- D) Shut off and/or disconnect air supply.

3.2.9 Filling the Reservoir

The reservoir level is graphically displayed on the control/display screen by the computer control system. When the level displayed is empty or prior to a long term test the reservoir should be filled. The 2500 humidity generator holds approximately one gallon of distilled water which can last from 12 hours to over 9 months of continuous use, depending on the temperature and humidity at which it is operated (reference section 1.6.5)

Note: Reservoir/presaturator system has been **EMPTIED** by factory prior to shipment.

To fill the reservoir:

- A) Press [STOP], if the generator is running, and allow all pressure to be vented.
- B) Remove the reservoir fill port cap located on the top left panel of the system.
- C) Add up to 1 gallon (3.8 liters) of double distilled water until the indicator on the front panel reads full. Use the reservoir fill funnel or a small funnel may be useful. Add the distilled water slowly so as not to overflow the reservoir.
- D) Replace fill port cap, finger tighten, and proceed with operation.

3.3 EDITING SYSTEM COEFFICIENTS AND PARAMETERS

All of the calibration coefficients and system parameters may be viewed and/or edited by the operator. The following is a summary of items that may be edited.

- Temperature Probe Calibration Coefficients
- Pressure Transducer Calibration Coefficients
- Flow Transducer Calibration Coefficients
- Probe and Transducer Averaging
- Serial Port Baud Rates, Parity, etc.
- Print Interval and Lines Per Page
- Time and Date

3.3.1 Edit Mode

The EDIT mode is used for the viewing and editing process.

1. From the Control/Display screen, press [EDIT/CAL]. Note, for this menu option to appear, the generator must not be RUNNING. In a few seconds, the following menu appears.

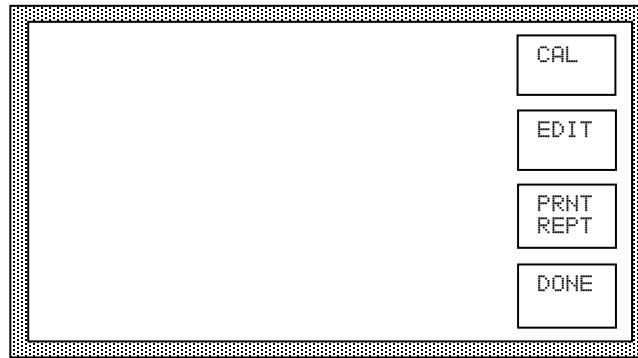

2. From the menu, press [EDIT].
3. At the prompt, enter in your authorization code (found at the back of the manual).



An incorrect code prevents access and returns to step 3. A correct code results in the display of calibration coefficients.

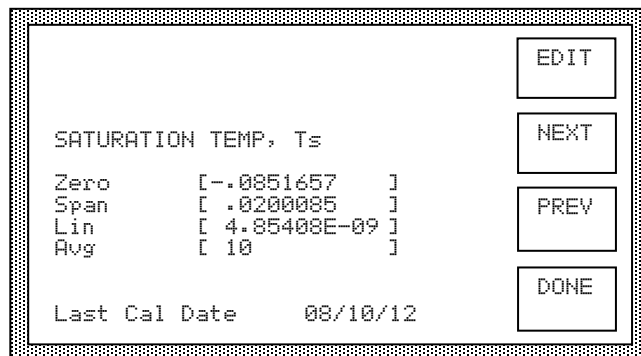

- Using the [NEXT] and [PREV] keys, view any or all of the remaining coefficient and parameter screens.

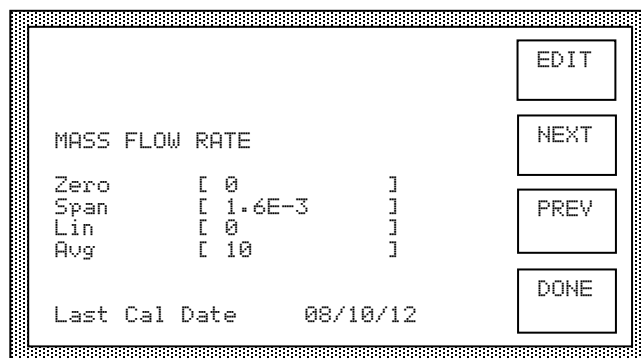

- To edit a particular displayed value, press [EDIT]. The cursor begins flashing at the left of the first parameter displayed.

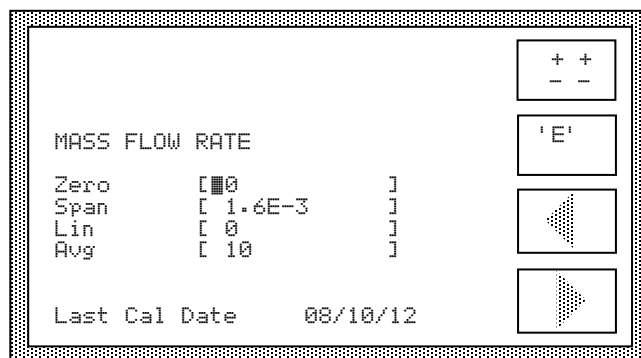

Using [±±], ['E'], arrow keys, and the numeric keys as necessary, change any or all displayed values as desired. Then press <ENTER>.

- After Editing or Viewing, press [DONE]. Then from the next menu, press [DONE] again. The system reinitializes back to the Control/Display screen.

3.3.2 Coefficients and Parameters

Each of the values on the various coefficient and parameter screens will be discussed in detail in the following sections.

3.3.2.1 Temperature Coefficients

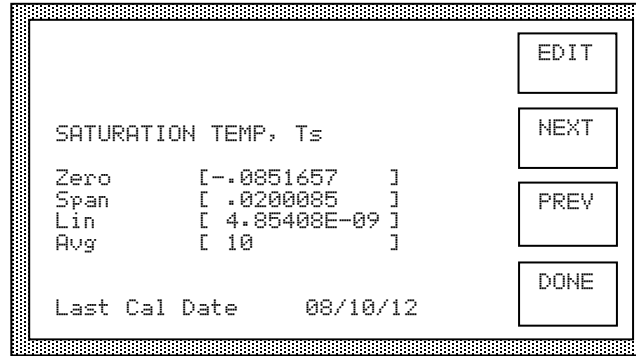

The ZERO, SPAN, and LIN values are coefficients to the formula

$$\text{Temp} = A + Bx + Cx^2$$

where A = zero coefficient
B = span coefficient
C = linearity coefficient
x = output of the STD-A/D converter board.

These coefficients are automatically computed during temperature calibration (section 4.2.2).

AVG is the amount of averaging applied to the displayed value. Averaging is applied with the formula

$$\text{New Value} = \{(\text{Previous Value} * \text{AVG}) + \text{New Reading}\} / (\text{AVG} + 1)$$

An AVG of zero (0) effectively eliminates averaging. An AVG which is very large has a correspondingly large averaging affect. Non-integer averaging amounts are allowable; however, negative amounts should never be used. An AVG of approximately 10 is typical, while an AVG of 1000 would be excessively high.

The date indicated at the bottom of the screen is the last date of calibration or the date of the most recent editing of any of the listed values. The date shown may not be edited and is updated automatically during calibration or when changing coefficients on this screen.

3.3.2.2 Reference Resistor Coefficients

These coefficients are similar to the temperature coefficients of section 3.3.2.4. The reference resistor is approximately 10KΩ, and the coefficients are chosen to provide a reference value of approximately 0 °C. An AVG amount of approximately 50 is typical.

Any change made to either the reference resistor or the coefficients (with the exception of AVG) requires that the temperature calibration of section 4.2.2 be performed on all four probes.

3.3.2.3 Pressure Coefficients

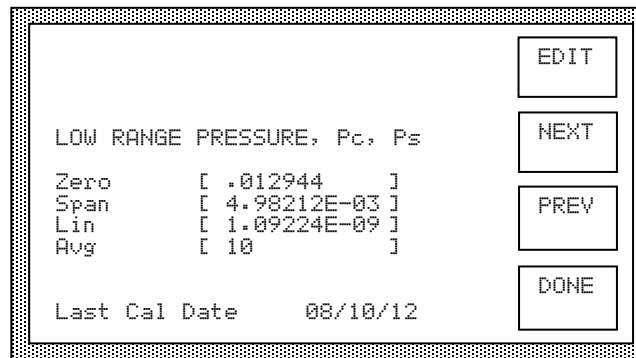

The ZERO, SPAN, and LIN values are coefficients to the formula

$$\text{Pressure} = A + Bx + Cx^2$$

where A = zero coefficient
B = span coefficient
C = linearity coefficient
x = output of the STD-A/D converter board.

These coefficients are automatically computed during pressure calibration (section 4.2.3)

AVG is the amount of averaging applied to the displayed value. Averaging is applied with the formula

$$\text{New Value} = \{(\text{Previous Value} * \text{AVG}) + \text{New Reading}\} / (\text{AVG} + 1)$$

An AVG of zero (0) effectively eliminates averaging. An AVG which is very large has a correspondingly large averaging affect. Non-integer averaging amounts are allowable; however, negative amounts should never be used. An AVG of approximately 10 is typical, while an AVG of 1000 would be excessively high.

The date indicated at the bottom of the screen is the last date of calibration or the date of the most recent editing of any of the listed values. The date shown may not be edited and is updated automatically during calibration or when changing coefficients on this screen.

3.3.2.4 Flow Coefficients

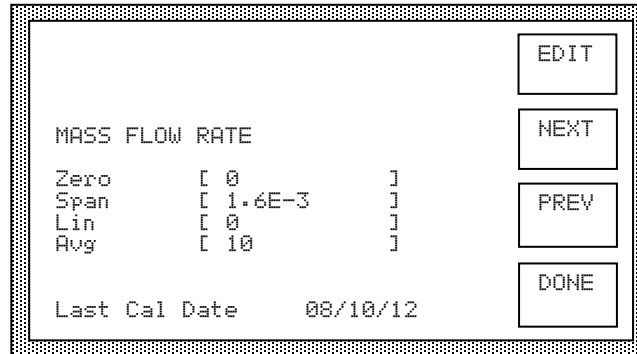

The ZERO, SPAN, and LIN values are coefficients to the formula

$$\text{Flow} = A + Bx + Cx^2$$

where A = zero coefficient
B = span coefficient
C = linearity coefficient
x = output of the STD-A/D converter board.

These coefficients are automatically computed during flow calibration (section 4.2.5)

AVG is the amount of averaging applied to the displayed value. Averaging is applied with the formula

$$\text{New Value} = \{(\text{Previous Value} * \text{AVG}) + \text{New Reading}\} / (\text{AVG} + 1)$$

An AVG of zero (0) effectively eliminates averaging. An AVG which is very large has a correspondingly large averaging affect. Non-integer averaging amounts are allowable; however, negative amounts should never be used. An AVG of approximately 10 is typical, while an AVG of 1000 would be excessively high.

The date indicated at the bottom of the screen is the last date of calibration or the date of the most recent editing of any of the listed values. The date shown may not be edited and is updated automatically during calibration or when changing coefficients on this screen.

3.3.2.5 Console Port Parameters

These parameters affect the manner in which the bi-directional RS-232C Console Port behaves. Changes become effective immediately.

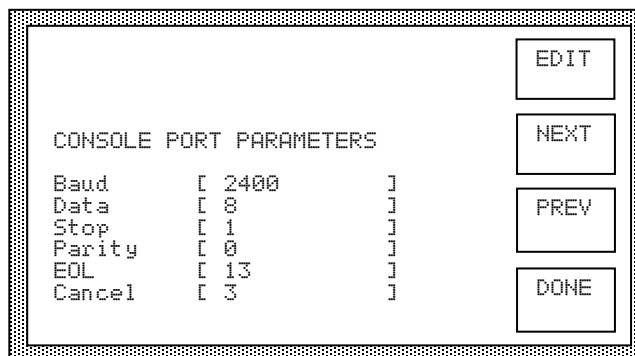

Baud: 300, 600, 1200, 2400, 4800, 9600, 19200 or 38400 bits per second

Data: 7 or 8 bit word size.

Stop: 1 or 2 stop bits

Parity: 0 for NO parity, 1 for ODD parity, or 2 for EVEN parity

EOL: The ASCII value of the desired End-Of-Line or terminator character. Here, '13' is the ASCII value for a Carriage Return.

Cancel: The ASCII value of the desired cancel-the-line character. Sending this character clears anything in the input buffer of the Console Port. Here, '3' is the ASCII value sent when executing a Control-C on most computers.

3.3.2.6 Printer Port Parameters

These parameters affect the manner in which the unidirectional RS-232 Printer Port behaves. It not only affects communication parameters, but time interval between printouts of system data, and the number of lines to print per page.

```
PRINTER PORT PARAMETERS
Baud      [ 9600      ]
Data      [ 8         ]
Stop      [ 1         ]
Parity    [ 0         ]
Intrvl    [ 60        ]
Lns/Pg    [ 50        ]
```

Baud: 300, 600, 1200, 2400, 4800, 9600, 19200 or 38400 bits per second

Data: 7 or 8 bit word size.

Stop: 1 or 2 stop bits

Parity: 0 for NO parity, 1 for ODD parity, or 2 for EVEN parity

Intrvl: The print interval, or number of seconds between printouts of system data.

Lns/Pg: Lines per Page of printed data.

3.3.2.7 Time and Date

This screen is used to change the Time and/or Date of the Real Time Clock. Note that time is input and displayed in military 24 hour format.

```
DATE 08/10/12
TIME 15:29:39
Month     [ 08        ]
Date      [ 10        ]
Year      [ 12        ]
Hour      [ 15        ]
Min       [ 29        ]
Sec       [ 39        ]
```

CALIBRATION AND MAINTENANCE

4.1 GENERAL

The Series 2500 humidity generation system requires little periodic maintenance. Following the proper operating procedures as given in this manual will help assure trouble-free operation of this system.

4.2 CALIBRATION

Proper calibration of the temperature and pressure transducers is critical to the accuracy of the generated humidity. Each time a transducer is calibrated its current calibration coefficients and calibration data are stored to non-volatile memory. Although not critical to system generation accuracy, the flowmeter coefficients and data are also retained in non-volatile memory.

Calibration of the system requires the following support equipment:

- 1) Temperature:
 - A. Temperature bath with a liquid medium (recommend Fluorinert, a 3M product), a range of 0-70 °C, and stability of ± 0.01 °C or better. Less stable baths may require the use of a thermal block.
 - B. Standard or reference thermometer (PRT or Thermistor) for the range of 0-70 °C with a resolution of 0.01 °C or better. Thermometer accuracy should be ± 0.05 °C or better.
- 2) Low Pressure (0-50 PSIA):
 - A. Static gas pressure source for the pressure range of ambient to 50 PSIA with a stability of ± 0.0025 PSIA or better.
 - B. Standard or reference pressure gauge for the range ambient to 50 PSIA with a resolution of ± 0.0025 PSIA. Gauge accuracy should be ± 0.025 PSIA or better.
- 3) High Pressure (50-150 PSIA):
 - A. Static gas pressure source for the pressure range of 50 to 150 PSIA with a stability of ± 0.01 PSIA or better.
 - B. Standard or reference pressure gauge for the range of 50 to 150 PSIA with a resolution of ± 0.01 PSIA or better. Gauge accuracy should be ± 0.10 PSIA or better.
- 4) Flow:
 - A. Standard or reference flowmeter for the range of 0 to 20 SLPM with a resolution of 0.1 SLPM or better. Flowmeter accuracy should be ± 0.5 SLPM or better.

Calibration of all transducers is to be performed "in the system, as a system". There are no provisions for, nor do we recommend, calibration of any of the transducers (temperature, pressure, or flow) while electrically disconnected from the generator. Since all calibration is performed mathematically by the computer, there are no manual adjustments.

Calibration is performed on all of the transducers by solving for the coefficients A, B, and C of the formula:

$$Y=A+Bx+Cx^2$$

where x is the raw count (or uncalibrated output of the A/D converter) while measuring a transducer, and

Y is the desired value (the standard or reference transducer's reading) for the transducer being calibrated.

The three coefficients A, B, and C are found by applying three separate, distinct, and stable references to each transducer, then solving the mathematical system of three equations with three unknowns. Since all of these calculations are performed automatically by the 2500's embedded computer, the operator need only be concerned with providing three known stable references required for the calibration of each transducer.

4.2.1 A/D Board (STD-A/D)

Equipment Required: (None)

All calibration errors appearing in the A/D board will be accounted for automatically during calibration of the temperature, pressure, and flow transducers. The board is also equipped with built in auto-zero and auto-span circuitry which automatically and continually accounts for short and long term drift in measurement accuracy. No user calibration is required. A board suspected of extreme inaccuracies or malfunctions should be sent to the factory for repair.

4.2.2 Temperature Calibration

The systems EDIT/CAL mode may be used in conjunction with a precision temperature bath for temperature probe calibrations. Any combination of one or more temperature probes may be calibrated at any one time, leaving calibration of the remaining probes unaltered.

By using the temperature bath to generate three known temperatures, all coefficients (ZERO, SPAN, LINEARITY) can be calculated automatically by the embedded computer and used to update the system calibration. A new calibration report may also be printed at the conclusion of the calibration sequence.

Equipment Required:

1. Temperature Bath (per section 4.2).
2. Standard or Reference thermometer (per section 4.2)
3. 7/16" open end wrench
4. Needle nose pliers
5. #10 Torx driver

4.2.2.1 Temperature Calibration Procedure

Reference Drawing 91D25902

- 1) Switch main console power OFF.
- 2) Turn OFF or disconnect the air supply.

CAUTION!
ALL SYSTEM PRESSURE MUST
BE VENTED BEFORE
PROCEEDING.

- 3) Using a #10 Torx driver, remove both top panels and the left rear panel from the generator. Remove the black foam insulation blocks and plugs from the openings.
- 4) Remove temperature probes to be calibrated.

Notes:

- (A) Remove the Chamber Temperature Probe by pulling the rubber cork and feeding the probe and cable through the chamber jacket opening.
 - (B) Before removing the Saturation Temperature Probe (RTD0), two gallons of heat transfer fluid must be drained. Remove the fill cap located on top of chamber. Locate the drain hose at bottom rear of console. Remove cap and drain the chamber fluid. Be sure to save fluid for refilling. Using the 7/16" wrench, remove the saturation temperature probe.
 - (C) Using the 7/16" wrench, remove the Presaturator Temperature Probe (RTD1) if desired.
 - (D) To gain access to the Expansion Valve Temperature Probe (RTD2), remove the foam insulation blocks from the expansion valve and drive assembly. Using needle nose pliers, loosen the knurled compression nut which holds the temperature probe. Gently slide the probe out, leaving the knurled nut assembly in place.
 - (E) Feed the temperature probes to be calibrated through the inside panel grommet and uncoil the cables.
- 5) Bring a precision temperature bath with reference thermometer to the system, and install thermistors to be calibrated into temperature bath.
 - 6) Switch main console power ON. Wait a few moments for the system to initialize and for the Control/Display screen to appear.

7) Press the [EDIT/CAL] key. The Edit/Cal menu appears.

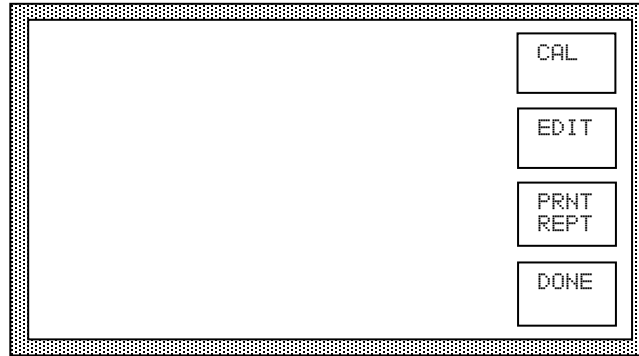

8) Press the [CAL] key. The calibration menu appears.

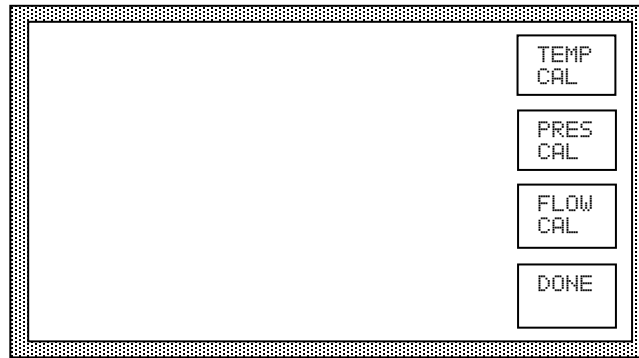

9) Press the [TEMP CAL] key. The probe selection screen appears.

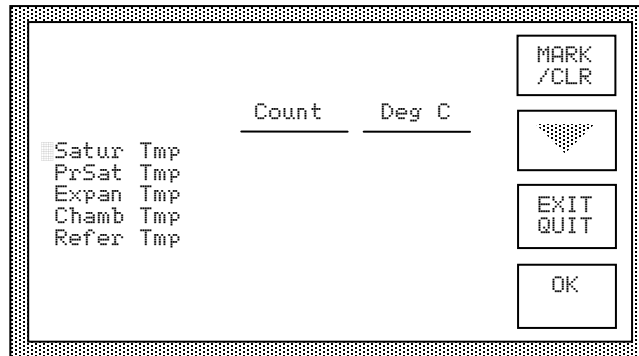

10) Using [MARK/CLR] and the down arrow key as necessary, mark the probes to be calibrated. A marked probe is indicated with an asterisk on the left. (Note that the "Refer Tmp" cannot be marked and is displayed for reference only.)

- 11) Once the desired probes are marked, press [OK]. The LOW, MID, and HIGH temperature reference values appear at the bottom of the screen, and within a few seconds, actual data begins updating in the "Count" and "Deg C" columns.

| | Count | Deg C | |
|------------|-------|-------|-----------|
| *Satur Tmp | 1180 | 23.41 | LOW TEMP |
| *PrSat Tmp | 1165 | 23.12 | MID TEMP |
| *Expan Tmp | 1173 | 23.20 | HIGH TEMP |
| *Chamb Tmp | 1155 | 23.08 | |
| Refer Tmp | 1257 | .1364 | |
| Low | Mid | High | EXIT QUIT |
| 0 | 35 | 70 | |

- 12) Adjust the temperature bath to a LOW temperature point at or near 0 °C and allow sufficient time for stability.
- 13) Once stable, press [LOW TEMP], and input the value of the Standard Thermometer as the LOW temperature. Use [\pm] and arrow keys as necessary.

| | Count | Deg C | |
|------------|-------|-------|------|
| *Satur Tmp | 183 | 3.446 | ++ |
| *PrSat Tmp | 167 | 3.143 | -- |
| *Expan Tmp | 173 | 3.228 | OOPS |
| *Chamb Tmp | 157 | 3.101 | ◀ |
| Refer Tmp | 1257 | .1476 | ▶ |
| Low | Mid | High | |
| 3.16 | 35 | 70 | |

Then press <ENTER>. The LOW temperature value just entered, and the values of each of the marked probes are automatically saved to memory for future computation of calibration coefficients.

Note: If a mistake was made during the temperature entry mode, use [OOPS] rather than <ENTER>. This will cancel the temperature entry mode and restore the previous "standard" and "marked" probe values to memory. For instance, [OOPS] could be used if the operator wanted to take the LOW temperature point, but had mistakenly pressed the [MID TEMP] key.

- Repeat step 13 for both a MID temperature (near 35 °C) and HIGH temperature (near 70 °C). Be sure to use the appropriate [MID TEMP] and [HIGH TEMP] keys.

Note: Using the LOW TEMP, MID TEMP, or HIGH TEMP key more than once allows the previous point of each thermistor to be over-written with the most current measured value. The reference thermometer value will also be over-written with the new value entered. The data stored is that which exists on the screen in the "Count" column when the LOW TEMP, MID TEMP, or HIGH TEMP key is pressed.

- After all three temperature points have been taken, press [CALC COEF] to calculate the new temperature coefficients for those probes which are marked. Unmarked probes retain their previous coefficients. The current coefficients for one probe will appear on the screen. Use the [VIEW NEXT] key to display coefficients for the other probes.

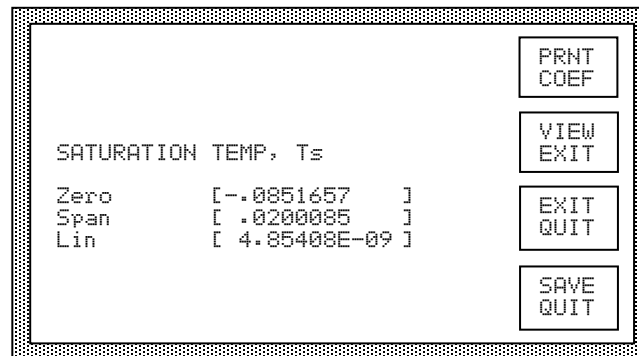

- Press the [PRNT COEF] key if a printout of the coefficients is desired.
- To update the calibration with new coefficients, press the [SAVE QUIT] key. To abort without storing these new coefficients, press the [EXIT QUIT] key.

Note: If the new coefficients were printed but not SAVED, the new coefficient values may be entered using the EDIT mode described in section 3.3.1.

- Check the accuracy of the calibration if desired, by repeating steps 9 through 12, however, don't "mark" any of the probes for calibration. Adjust the temperature bath to any values between 0 and 70 °C and visually compare readings.
- Switch main console power OFF.
- Re-install all temperature probes. Tighten all connections just past finger tight.
- Cap the chamber fluid drain valve and refill the chamber fluid jacket with the water/glycol mixture which was removed in step 4(B).
- Replace all covers and panels. The system must not be operated unless ALL panels are in place.
- To print a calibration report, refer to section 4.2.5.

4.2.3 Pressure Transducer Calibration

Pressure Transducer Calibration is typically performed in a calibration laboratory and requires that the transducers be removed from the pneumatic system of the 2500, but must remain electrically connected. The pressure readings must be precise in order to retain accurate relative humidity calculations.

Equipment Required:

1. Static pressure source, range ambient to 50 PSIA (per section 4.2).
2. Static pressure source, range 50 to 150 PSIA (per section 4.2).
3. Standard or reference pressure gauge, range ambient to 50 PSIA (per section 4.2).
4. Standard or reference pressure gauge, range 50 to 150 PSIA (per section 4.2).
5. 9/16" and 11/16" open end wrenches.
6. #10 Torx driver.
7. Flat blade screw driver.

4.2.3.1 Pressure Calibration Procedure

- 1) Switch console power OFF.
- 2) Turn OFF or disconnect air supply.

CAUTION!
ALL SYSTEM PRESSURE MUST
BE VENTED BEFORE
PROCEEDING.

- 3) Bring the pressure source to the generator or take the generator to the pressure calibration lab.
- 4) Using a #10 Torx driver, remove top left console panel.
- 5) Disconnect pressure transducers (11/16" & 9/16" wrench required). Using a screwdriver, pry open the round snap-lock transducer mounts, and remove the transducers. Ensure the electrical connectors are in place.
- 6) Connect the pressure source to the transducer to be calibrated (one only).

Note: Each transducer is operated over a limited range and requires calibration within this range only.

- a) 0-50 PSIA Transducer - Calibrate from ambient to 50 PSIA.
- b) 0-150 PSIA Transducer - Calibrate from 50 to 150 PSIA.

- 7) Switch console power ON. Wait a few moments for the softkey menu to appear. Allow approximately 30 minutes or more for warm-up of the pressure transducer electronics.
- 8) Press the [EDIT/CAL] key, then the [CAL] key. The calibration menu appears.

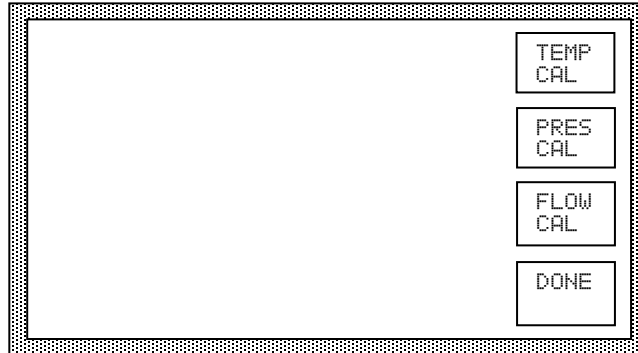

- 9) Press the [PRES CAL] key.
- 10) Using [MARK/CLR] and the down arrow key as necessary, mark the transducer to be calibrated. A marked transducer is indicated with an asterisk in the left most display column. Since the two transducers require different calibration ranges, the computer will only allow you to mark one transducer at a time.

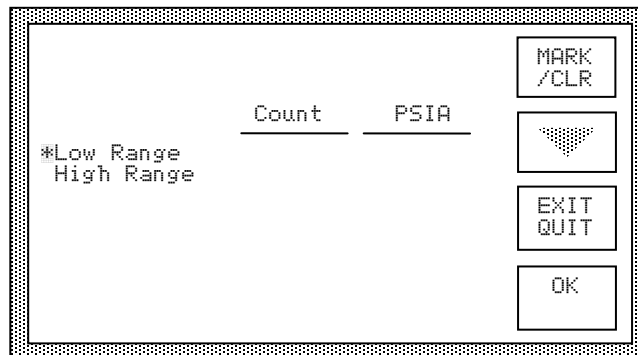

- 11) Press [OK], or if a mistake was made, press [EXIT QUIT]. [EXIT QUIT] reverts to step 9.

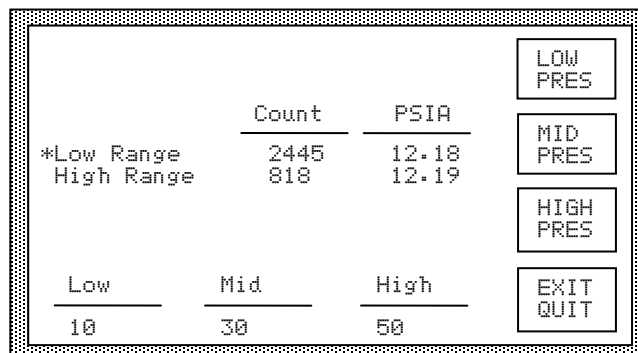

- 12) Apply the lower recommended calibration pressure and watch the displayed value. Once stable, press the [LOW PRES] key and enter the reference pressure. Then press <ENTER>.

| | | | |
|------------|-------|-------|----------|
| | | | ++ -- |
| | Count | PSIA | OOPS |
| *Low Range | 2444 | 12.18 | |
| High Range | 817 | 12.18 | |
| | | | ◀ |
| Low | Mid | High | ▶ |
| 12.214 | 30 | 50 | |

Note: For the low range transducer, ambient pressure should be used for the low pressure calibration point.

Note: If a mistake is made during reference pressure entry, pressing the [OOPS] key cancels the data entry mode, leaving all values unchanged.

- 13) Apply the mid range pressure and watch the displayed value. Once stable, press the [MID PRES] key and enter the reference pressure. Then press <ENTER>.

| | | | |
|------------|--------|-------|----------|
| | | | ++ -- |
| | Count | PSIA | OOPS |
| *Low Range | 6028 | 30.11 | |
| High Range | 816 | 12.17 | |
| | | | ◀ |
| Low | Mid | High | ▶ |
| 12.214 | 29.989 | 50 | |

- 14) Apply the upper recommended pressure and watch the displayed value. Once stable, press the [HIGH PRES] key and enter the reference pressure. Then press <ENTER>.

| | | | |
|------------|--------|--------|----------|
| | | | ++ -- |
| | Count | PSIA | OOPS |
| *Low Range | 10021 | 49.92 | |
| High Range | 816 | 12.17 | |
| | | | ◀ |
| Low | Mid | High | ▶ |
| 12.214 | 29.989 | 49.904 | |

| | Count | PSIA | |
|------------|--------|--------|-----------|
| *Low Range | 10021 | 49.92 | LOW PRES |
| High Range | 817 | 12.16 | MID PRES |
| | | | HIGH PRES |
| Low | Mid | High | CALC COEF |
| 12.214 | 29.989 | 49.904 | |

- 15) Press the [CALC COEF] key. All coefficients for the marked transducer will be calculated, and those of the low range transducer will appear first on the LCD display.

| | | | |
|----------------------------|-----------------|--|-----------|
| | | | PRNT COEF |
| LOW RANGE PRESSURE, Pc, Ps | | | VIEW NEXT |
| Zero | [.014394] | | EXIT QUIT |
| Span | [4.98212E-03] | | SAVE QUIT |
| Lin | [1.09224E-09] | | |

- 16) Press [VIEW NEXT] to view the coefficients of the other transducer if desired.
- 17) To obtain a printout of the new coefficients, press [PRNT COEF].
- 18) To save the coefficients, press [SAVE QUIT]. The coefficients will be stored to non-volatile memory. To abort the calibration without saving the coefficients just calculated, press [EXIT QUIT]. The previous coefficients will be reinstated.
- 19) At the calibration menu, press [DONE]. Then press [DONE] at the next menu. The system reinitializes and the Control/Display screen appears.
- 20) Repeat steps 9 thru 19 for the second pressure transducer.
- 21) Switch main console power to OFF.
- 22) Re-install the pressure transducers (0-50 PSIA transducer T2 is on top). Tighten all connections 1/4 turn past finger tight.
- 23) Replace top left console panel. The system must not be operated unless all panels are in place.
- 24) To print a calibration report, refer to section 4.2.5.

4.2.4 Flow Transducer Calibration

The flow measurement, while indicated on the screen, is not critical to the accuracy of the generated humidity and is not used in the humidity calculations. Flow calibration accuracy depends upon the requirements of the user.

Equipment Required:

1. Standard or Reference flowmeter (per section 4.2).

4.2.4.1 Flow Calibration Procedure

The calibration for the flowmeter is slightly different than for the temperatures and pressures, and does not require the removal of the flowmeter from the system.

- 1) Using appropriate fittings, connect a flowmeter reference instrument to the chamber inlet port of the system.
- 2) Generate 10 standard liters per minute at approximately 10% RH at 21 °C. Once stable, note the readings of the reference flowmeter and of the indicated flow of the 2500.
- 3) Change the flow to 20 standard liters per minute and note both readings again.
- 4) Press [STOP]. Once the shutdown is complete, press [EDIT/CAL]. The following menu appears.

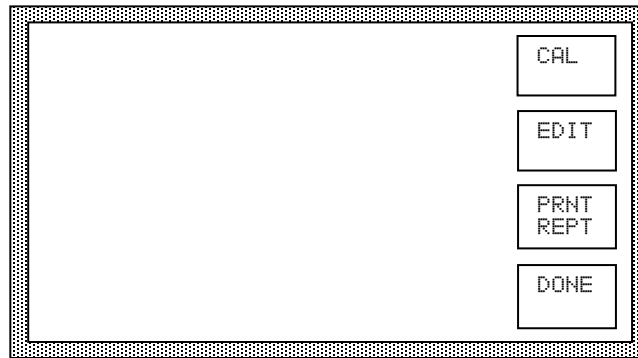

- 5) Press [CAL]. The calibration menu appears.



6) Press [FLOW CAL].

7) Press [MARK/CLR] to mark the flowmeter (indicated by an asterisk to its left).

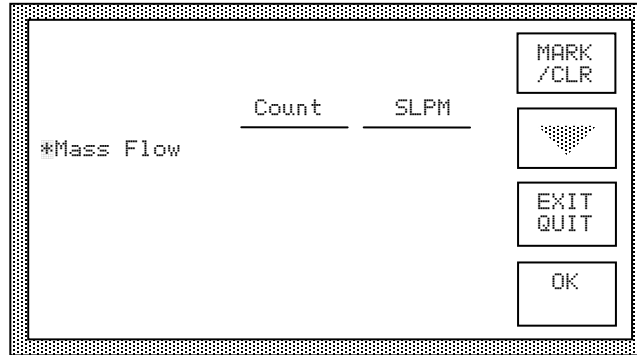

8) Press [OK]. Within a few seconds, the measured flow readings begin updating.

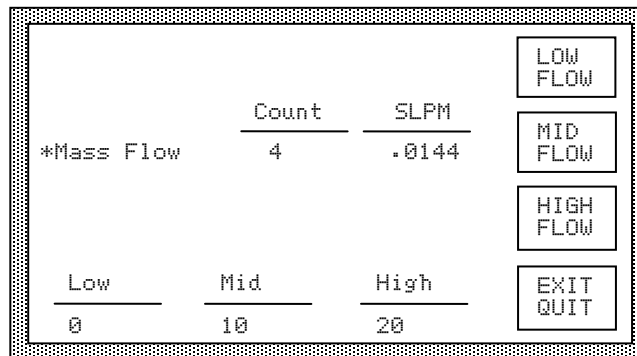

9) Allow a few moments for stability of the flow indication. This "no flow" condition will be used for a LOW flow reference. Press [LOW FLOW] to store this point. Then press <ENTER>.

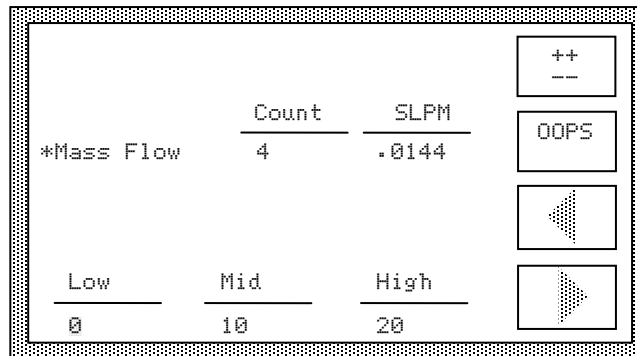

10) Using the 10 liter data obtained in step 2, calculate the following:

$$10 + (\text{Reference Indication}) - (2500 \text{ Indication})$$

Press [MID FLOW] and enter this calculated value.

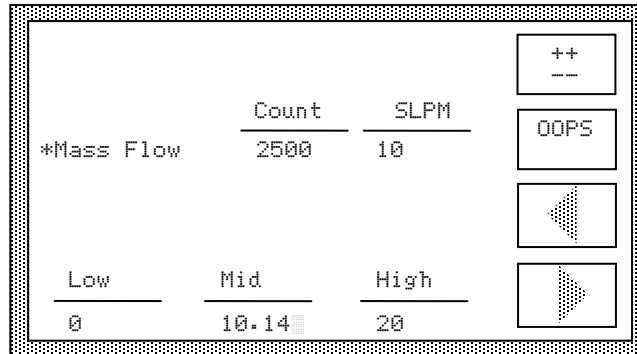

11) Using the 20 liter data obtained in step 3, calculate the following:

$$20 + (\text{Reference Indication}) - (2500 \text{ Indication})$$

Press [HIGH FLOW] and enter this calculated value.

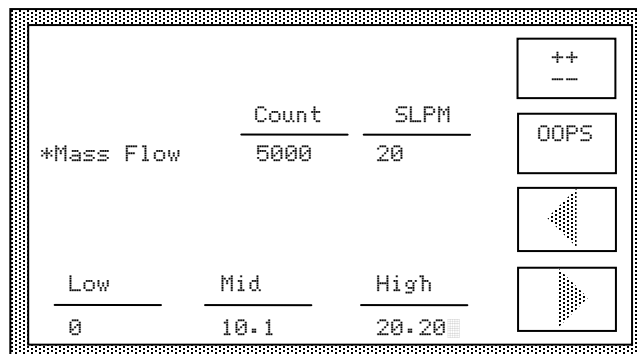

12) Press [CALC COEF] to calculate the new flowmeter coefficients.

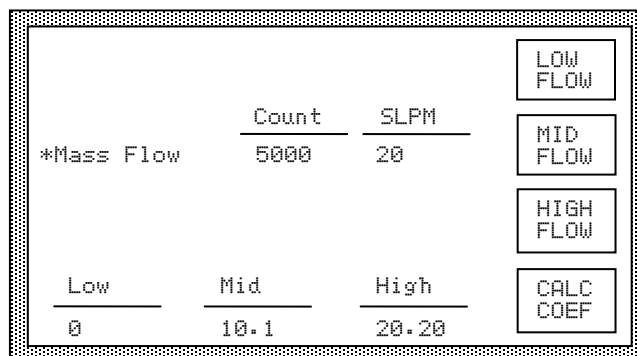

These new coefficients appear on the display.

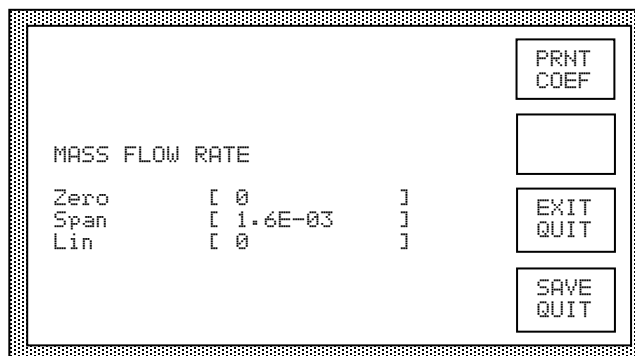

- 13) To obtain a printout of the new coefficients, press [PRNT COEF].
- 14) To save the coefficients to non-volatile memory, press [SAVE QUIT]. To discard these new coefficients and revert to the previous ones, press [EXIT QUIT].
- 15) At the calibration menu, press [DONE]. At the next menu, press [DONE] again. The system reinitializes to the Control/Display screen.
- 16) To print a calibration report, refer to section 4.2.5.

4.2.5 Printing the Calibration Report

If a printer is connected to the Printer Port, a report may be printed which lists the calibration coefficients and calibration dates for the temperature, pressure, and flow transducers. The report is printed from the Edit/Cal menu.

To print the report:

- 1) From the Control/Display screen press [EDIT/CAL], or from the Cal menu press [DONE]. Both actions should bring up the Edit/Cal menu.
- 2) Ensure the printer is on, then press [PRNT REPT]. The Calibration Report will be sent to the printer.
- 3) Press [DONE] to return to the Control/Display screen.

To save the report:

- 1) From the Control/Display screen press [EDIT/CAL], or from the Cal menu press [DONE]. Both actions should bring up the Edit/Cal menu.
- 2) Using the computer cable supplied and a gender changer, connect a PC from its COM port to the printer port of the 2500. Open the application "HyperTerminal" and configure it to match the printer port parameters i.e. Baud, Data, Stop, Parity. Select Capture Text from the Transfer menu and press [PRNT REPT] from the 2500 control panel. When data output is finished, select Capture Text – Stop from the Transfer

menu. Where and when appropriate, open the file containing the Calibration Report with WordPad. The last character in the file is a small square. Delete this. From the **File-Page Setup...** menu, set all four margins to one (1) inch. Print the data from within WordPad.

3) Press [DONE] to return to the Control/Display screen.

Note: System data may also be logged this way during normal system generating mode, either with “Print On Demand” or timed interval printing.

A sample of the calibration report follows:

Calibration Report
for
TSC Model 2500 Humidity Generator

S/N XXXXXXXX
Date MM/DD/YY

| Temperature | Zero | Span | Linearity | Cal Date |
|-------------------------|--------------|-------------|-------------|----------|
| Saturation Temperature | 0.00000E+00 | 1.00000E-02 | 0.00000E+00 | MM/DD/YY |
| Presat Temperature | 0.00000E+00 | 1.00000E-02 | 0.00000E+00 | MM/DD/YY |
| Ex Valve Temperature | 0.00000E+00 | 1.00000E-02 | 0.00000E+00 | MM/DD/YY |
| Chamber Temperature | 0.00000E+00 | 1.00000E-02 | 0.00000E+00 | MM/DD/YY |
| Temp Reference Resistor | -2.50000E+01 | 1.00000E-02 | 0.00000E+00 | MM/DD/YY |

| Pressure | Zero | Span | Linearity | Cal Date |
|-----------------------|-------------|-------------|-------------|----------|
| Low Range (0-50 psia) | 0.00000E+00 | 2.00000E-03 | 0.00000E+00 | MM/DD/YY |
| Hi Range (0-150 psia) | 0.00000E+00 | 6.00000E-03 | 0.00000E+00 | MM/DD/YY |

| Flow | Zero | Span | Linearity | Cal Date |
|----------------|-------------|-------------|-------------|----------|
| Mass Flow Rate | 0.00000E+00 | 1.60000E-03 | 0.00000E+00 | MM/DD/YY |

Certified by _____

Date _____

4.3 ROUTINE MAINTENANCE

4.3.1 Console Intake: Monthly

- 1) Locate console intake on left side of generating console.
- 2) Remove any dust and other obstructions.

4.3.2 Chamber Fluid Level: Yearly

- 1) Remove top right console panel.
- 2) Locate fluid fill cap on top of console (under black insulating foam).
- 3) Remove cap and check that the fluid is approximately 1/4" (6.35mm) below bottom of fill port.
- 4) If fluid level is low, add distilled water as necessary.
- 5) Replace fluid fill cap and black insulating foam.
- 6) Replace console panel.

4.3.3 Pre-saturator Drain: Yearly

- 1) Turn main power ON and perform reservoir fill procedure (per section 3.2.9).
- 2) Turn main power switch OFF and remove power cord.
- 3) Remove left rear panel using a number 10 Torx tool.
- 4) Locate the Pre-saturator drain cap (Swagelok cap, to the left of the circulation pump).
- 5) Loosen (do not remove) the drain cap using a 9/16" wrench.
- 6) Prepare a 1/4" plastic drain tube, approximately 4' to 6' long, with a Swagelok nut and ferrule assembly on one end.
- 7) Place the open end of the tube into a bucket and place the Swagelok nut assembly in close proximity to the Pre-saturator drain cap.
- 8) Remove the Pre-saturator cap and quickly place a finger over the open fitting to stop water flow then quickly remove your finger and insert the tube into the fitting. Tighten Swagelok nut finger tight.
- 9) Allow Pre-saturator to drain.
- 10) Remove drain tube assembly and replace drain cap. Tighten 1/8 turn past finger tight.
- 11) Replace left rear panel.
- 12) Re-install power cord. Turn power switch ON.
- 13) Press "Run" at the front panel.
- 14) After initialization the screen will indicate "PreSat Filling". If "PreSat Filling" times out an error code 16 "PreSat Water Empty" will occur and an alarm will sound. If this happens, switch the main power OFF and then back ON then press "Run" again.
Note: It may be necessary to repeat this step two or three times until the Pre-saturator is full.
- 15) When the Pre-saturator is full press "Shutdown" and switch power OFF.

4.3.4 Mobile Pneumatic Cart: Daily

- 1) Drain condensation from pressure tank using drain valve on bottom.
- 2) Drain condensation from inline air filter sumps using drain valves on bottoms.
- 3) For air compressor maintenance please refer to bulletin ACS2520 "Installation, Operation, Parts List and Maintenance" located in the back of this manual.

4.4 ERROR CODES and TROUBLESHOOTING

Prior to system start-up, and during humidity generation, the system monitors itself for errors and sources of possible malfunction. When a catastrophic error occurs, the system automatically shuts down, then alerts the operator with a visual flashing message and an audible tone. The visual message displays the error number and a brief description of the problem.

It is possible (in many cases probable) to have multiple errors occurring at one time. Under these circumstances, the error codes simply add together algebraically, and all of the associated messages are displayed in turn. Any error code greater than 16383 will be displayed as a negative number. In this case, simply add 65536 to the displayed number to calculate the appropriate code. While it is not necessary to understand the error code system, it is important to write down the error code number exactly as it appears on the screen when consulting the factory for technical support. Little can be done to ascertain the nature of the problem without the exact error code.

The following is a list of error codes and a brief description of each.

| <u>ERROR CODE</u> | <u>DESCRIPTION</u> |
|-------------------|--|
| 1 | Expansion Valve Not Closing |
| 2 | Flow Valve Not Closing |
| 4 | No Supply Pressure |
| 8 | Reservoir Needs Water |
| 16 | Presaturator Water Empty |
| 32 | Low Pressure Underrange |
| 64 | Low Pressure Overage |
| 128 | High Pressure Underrange |
| 256 | High Pressure Overage |
| 288 | Pressure Transducer Failure |
| 320 | Low Pressure Overage (Saturation Pressure) |
| 480 | Pressure Transducer Misalignment |
| 512 | Saturation Temperature High/Low limit |
| 1024 | Presaturation Temperature High/Low limit |
| 2048 | Expansion Valve Temperature High/Low limit |
| 4096 | Chamber Temperature High/Low limit |
| 8192 | Temperature Reference High/Low limit |
| 16384 | Temperature Underrange |
| 16896 | Saturation Temperature Underrange |
| 17408 | Presaturator Temperature Underrange |
| 18432 | Expansion Valve Temperature Underrange |
| 20480 | Chamber Temperature Underrange |
| 24576 | Reference Temperature Underrange |
| -16384 | Cabinet Temperature Overage |
| -24576 | Reference Temperature Overage |
| -28672 | Chamber Temperature Overage |
| -30720 | Expansion Valve Temperature Overage |
| -31744 | Presaturator Temperature Overage |
| -32256 | Saturation Temperature Overage |
| -32768 | Temperature Overage |

Error 1 - Expansion Valve Not Closing

This indicates that while attempting to close the expansion valve, the HOME position limit switch closure was not detected. This could mean that either the valve is not moving properly or the switch is mechanically or electrically malfunctioning.

Error 2 - Flow Valve Not Closing

This indicates that while attempting to close the flow valve, the HOME position limit switch closure was not detected. This could mean that either the valve is not moving properly or the switch is mechanically or electrically malfunctioning.

Error 4 - No Supply Pressure

This indicates that there is insufficient air supply pressure to continue. Check the air supply (either in-house or the cart air supply). A malfunction of solenoid valve SOL1 or solid state relay SSR5 may also cause this problem.

Error 8 - Reservoir Needs Water

The reservoir is empty and needs water. Fill with one (1) gallon of distilled water. This error only occurs during startup, immediately after pressing the [RUN] key.

Error 16 - Presaturator Water Empty

The presaturator has run empty due either to an empty reservoir or a malfunctioning filling system.

Error 32 - Low Pressure Underrange

The low range pressure transducer indicates a pressure below 10 PSIA or equivalent in other pressure units. The most likely cause is a pressure transducer malfunction.

Error 64 - Low Pressure Overrange

The low range pressure transducer indicates a chamber pressure above 20 PSIA or equivalent in other pressure units. One possible cause would be a malfunction of the pressure select solenoid SOL5. This error may also indicate a low range pressure transducer malfunction.

Error 128 - High Pressure Underrange

The high range pressure transducer indicates a pressure below 10 PSIA or equivalent in other pressure units. The most likely cause is a pressure transducer malfunction.

Error 256 - High Pressure Overrange

The high range pressure transducer indicates a pressure above 165 PSIA or equivalent in other pressure units. The most likely cause is a pressure transducer malfunction.

Error 288 - Pressure Transducer Failure

This indicates that a measurement error of greater than 10 PSIA, or equivalent in other pressure units, was observed on one of the pressure transducers. Likely causes include pressure transducer malfunction or failure of the pressure select solenoid SOL5.

Error 320 - Low Pressure Overrange

This indicates that a saturation pressure of greater than 60 PSIA, or equivalent in other pressure units, was measured by the low range pressure transducer. Transducer malfunction (either one or both) is likely.

Error 480 - Pressure Transducer Misalignment

The low and high range pressure transducer measurements disagree with each other by more than 1 PSIA or equivalent in other pressure units, indicating an alignment problem. The most likely cause is improper calibration or malfunction of one or both pressure transducers.

Error 512 - Saturation Temperature High/Low limit

This error occurs only in combination with an Over/Underrange Limit. If combined with error code 16384 Temperature Underrange, the saturation temperature is below -10 °C (14 °F). If combined with error code -32768 Temperature Overrange, the saturation temperature is above 90 °C (194 °F). The most likely cause is misalignment or malfunction of the temperature probe.

Error 1024 - Presaturation Temperature High/Low limit

This error occurs only in combination with an Over/Underrange Limit. If combined with error code 16384 Temperature Underrange, the presaturator temperature is below -5 °C (23 °F). If combined with error code -32768 Temperature Overrange, the presaturator temperature is above 100 °C (212 °F). The most likely cause is misalignment or malfunction of the temperature probe.

Error 2048 - Expansion Valve Temperature High/Low limit

This error occurs only in combination with an Over/Underrange Limit. If combined with error code 16384 Temperature Underrange, the expansion valve temperature is below -10 °C (14 °F). If combined with error code -32768 Temperature Overrange, the expansion valve temperature is above 100 °C (212 °F). The most likely cause is misalignment or malfunction of the temperature probe.

Error 4096 - Chamber Temperature High/Low limit

This error occurs only in combination with an Over/Underrange Limit. If combined with error code 16384 Temperature Underrange, the chamber temperature is below -10 °C (14 °F). If combined with error code -32768 Temperature Overrange, the chamber temperature is above 100 °C (212 °F). The most likely cause is misalignment or malfunction of the temperature probe.

Error 8192 - Temperature Reference High/Low limit

The temperature reference resistor indication has deviated significantly from its nominal value of 0 °C (32 °F). This typically indicates a bad reference resistor, or a malfunctioning STD-A/D converter board.

Error 16384 - Temperature Underrange

This error never occurs alone. It may only occur in combination with temperature high/low limits to indicate that the error is a low limit rather than a high limit.

Error 16896 - Saturation Temperature Underrange

The indicated saturation temperature is below -10 °C (14 °F). Suspect misalignment or malfunction of the saturation temperature probe.

Error 17408 - Presaturation Temperature Underrange

The indicated presaturation temperature is below -5 °C (23 °F). Suspect misalignment or malfunction of the presaturator temperature probe.

Error 18432 - Expansion Valve Temperature Underrange

The indicated expansion valve temperature is below -10 °C (14 °F). Suspect misalignment or malfunction of the expansion valve temperature probe.

Error 20480 - Chamber Temperature Underrange

The indicated chamber temperature is below -10 °C (14 °F). Suspect misalignment or malfunction of the chamber temperature probe.

Error 24576 - Reference Temperature Underrange

The temperature reference resistor is below its nominal value of 0 °C (32 °F). This typically indicates a faulty reference resistor or malfunctioning STD-A/D converter board.

Error -16384 - Cabinet Temperature Overage

The measured cabinet temperature is too high. Most likely causes include a blocked or clogged intake vent on the left side of the unit, a blocked outlet at the back of the unit, or a faulty fan.

Error -24576 - Reference Temperature Overage

The temperature reference resistor is well above its nominal value of 0 °C (32 °F). This typically indicates a faulty reference resistor or malfunctioning STD-A/D converter board.

Error -28672 - Chamber Temperature Overage

The indicated chamber temperature is above 100 °C (212 °F). Suspect misalignment or malfunction of the chamber temperature probe.

Error -30720 - Expansion Valve Temperature Overage

The indicated expansion valve temperature is above 100 °C (212 °F). Suspect misalignment or malfunction of the expansion valve temperature probe.

Error -31744 - Presaturation Temperature Overage

The indicated presaturation temperature is above 100 °C (212 °F). Suspect misalignment or malfunction of the presaturator temperature probe.

Error -32256 - Saturation Temperature Overrange

The indicated saturation temperature is above 90 °C (194 °F). Suspect misalignment or malfunction of the saturation temperature probe.

Error -32768 - Temperature Overrange

This error never occurs alone. It may only occur in combination with temperature high/low limits to indicate that the error is a high limit rather than a low limit.

Section 5

PARTS LISTS

| 5.1 COMPUTER CONTROL SYSTEM | | Ref. Drawing 91D25903 | | |
|------------------------------------|------|--------------------------|--------------------|-------------|
| Find # | Qty. | Description | Mfg. | Part Number |
| STD-A/D | 1 | Analog A/D Board | Sensoray | MCM7418 |
| STD-CPU | 1 | CPU Board | Thunder Scientific | D93A25036 |
| STD-LCD | 1 | Display Controller Board | Thunder Sci | D96A00228 |
| STD-MEM | 1 | Memory Board | Thunder Sci | D93A25037 |
| STD-PS | 1 | Power Supply Board | Thunder Sci | D93A25039 |

| 5.2 ELECTRICAL SYSTEM | | Ref. Drawings 91D25904-5 & 91S25906-14,08S25942 | | |
|------------------------------|------|---|----------------------|--------------------------|
| Find # | Qty. | Description | Mfg. | Part Number |
| ATB | 1 | Analog Terminal Board | Sensoray | AD7P409TB |
| CC | 1 | Card Cage | Thunder Sci | D92A25013 |
| CBS1 | 1 | Power Switch | Carling Technologies | BTPWRSW-R * BTPWRSW-2 |
| CF1 | 1 | Console Fan | Comair Rotron | MR2B3 * MR77B3 |
| FB1 | 1 | Core, Ferrite | Fair-Rite | FERCORE |
| FS1 | 1 | Fuse, 4A | Littelfuse | WK4062BK |
| FS2 | 1 | Fuse, 4A | Bussmann | GDC-4A |
| FS3 | 1 | Fuse, 3.15A | Bussmann | S506-3.15 |
| | 1 | Fuse, 1.6A | Bussmann | * S506-1.6 |
| HLS1 | 1 | Heat Limit Switch | Selco | HLSW1 |
| HLS2 | 1 | Heat Limit Switch | Selco | HLSW2-EPOXY |
| HLS3 | 1 | Heat Limit Switch | Airpax Sensata | THRMST110 |
| H1-2 | 2 | Heater, Cartridge | Heatron | L3A82 |
| H3 | 1 | Heater, Cartridge | Heatron | N9N-1560 *** N8A21 |
| H4 | 1 | Foil Heater (5.69 ohms) | Minco | HK6020 |
| H5 | 1 | Foil Heater (22.0 ohms) | Heatron | HK5161 |
| | 2 | Foil Heater (22.0 ohms) | Heatron | *** HK5161 |
| KB | 1 | Keypad | Memtron | D91M25281 |
| LCD | 1 | Liquid Crystal Display | LCD Systems | DMF6104 |
| LCD-INV | 1 | Inverter Board (Back-Light) | TDK-Lambda | D08A25045 |
| LL1 | 1 | Liquid Level, Reservoir | Thunder | D94A25051 |
| LL2 | 1 | Liquid Level, Presaturator | Thunder | D92A00043 |
| MB | 1 | Mother Board Card | Thunder Sci | D92A25024 |
| MOV1 | 3 | Varistor, Metal Oxide | NTE Electronics | MOV1 |
| PLF1 | 1 | Filter, Power Line | Curtis Industries | F1200BB03 |
| RTD2,3 | 3 | Sensor, Temperature | BetaTHERM | BTPROBE3 |
| RTD1 | 1 | Sensor, Temperature | BetaTHERM | THRMPB4 |
| SL-1,2 | 2 | Switch, Limit | Honeywell | MCRSW2 |
| SMD-1,2 | 2 | Driver, Stepper Motor | Net Motion | RD-022 |
| SM-1,2 | 2 | Motor, Stepper | Oriental Motor | PX243G |
| SPKR | 1 | Minilert Audible Signal | Mallory | MINLRT |

| | | | | |
|---------|----|--------------------------|------------------|-----------|
| SSRB | 1 | SSR Module Board | Octagon Systems | OP2512 |
| SSR0-7 | 8 | AC SSR Module | Opto 22 | G4AC5 |
| SSR8-10 | 3 | 10 Amp SSR | Opto 22 | 240D10 |
| TB1-1-4 | 4 | Terminal Block | Phoenix Contact | PH3001682 |
| TB1-5-7 | 3 | Terminal Block | Phoenix Contact | PH1415089 |
| TB2 | 10 | Terminal Block | Phoenix Contact | PH3100305 |
| TB3 | 1 | Terminal Block | Cinch Connectors | TRM7 |
| TIB | 1 | Terminal Block Interface | Octagon Systems | TBD-100 |
| TR1 | 1 | Power Transformer | Triad Magnetics | F108U |

| 5.3 PNEUMATIC SYSTEM | | | Reference Drawing 91S25916 | |
|-----------------------------|------|----------------------|----------------------------|----------------------------------|
| Find# | Qty. | Description | Mfg. | Part Number |
| G1 | 1 | Gauge, Pressure | Grainger | G6X114 |
| PSAT | 1 | Presaturator | Thunder | D94A25048 ***** D94A25048-HAF |
| PT1 | 1 | Tee, Purge | Swagelok | S4-3 |
| REG | 1 | Regulator, Pressure | Norgren | REGNG200 |
| RES | 1 | Reservoir | Thunder | D92A25015 |
| RTD2,3 | 2 | Sensor, Temperature | BetaTHERM | BTPROBE3 |
| RTD1 | 1 | Sensor, Temperature | BetaTHERM | THRMPB4 |
| RV1 | 1 | Valve, Relief | Nupro | S4C-150 |
| SAT | 1 | Saturator | Thunder | D94A25048 ***** D94A25048-HAF |
| SOL1 | 1 | Valve, Solenoid | KIP Norgren | A2033 |
| SOL3 | 1 | Valve, Solenoid | KIP Norgren | A2231 |
| SOL4 | 1 | Valve, Solenoid | KIP Norgren | A2037 |
| SOL5 | 1 | Valve, Solenoid | KIP Norgren | B3331 |
| T1 | 1 | Transducer, Flow | Sierra Instruments | FL824 |
| T2 | 1 | Transducer, Pressure | Honeywell Sensing | PTE50 |
| T3 | 1 | Transducer, Pressure | Honeywell Sensing | DCT150A |
| V1 | 1 | Valve, Flow | Thunder | D91A25058 |
| V2 | 1 | Valve, Expansion | Thunder | D91A25060 ***** D91A25060-HAF |

| 5.4 HEAT TRANSFER FLUID SYSTEM | | | Reference Drawing 91S25917 | |
|---------------------------------------|------|-------------------------|----------------------------|--|
| Find# | Qty. | Description | Mfg. | Part Number |
| EX1 | 1 | Exchanger, Heat | Thunder | D92A25018 |
| FP1 | 1 | Pump, Centrifugal Fluid | Franklin Electric Co. | TE3MDHC * TE3MDHC230 *** ST3MDHC230/60 *** ST977899 *** ST581697 |
| H3 | 1 | Heater, Cartridge | Heatron | N9N-1560 *** N8A21 |
| RTD0 | 1 | Sensor, Temperature | BetaTHERM | BTPROBE3 |
| SAT | 1 | Saturator | Thunder | D94A25048 ***** D94A25048-HAF |

| | |
|---------------------------------|----------------------------|
| 5.5 REFRIGERATION SYSTEM | Reference Drawing 91S25918 |
|---------------------------------|----------------------------|

| Find# | Qty. | Description | Mfg. | Part Number |
|-------|------|------------------------|-------------------|-------------------|
| C1 | 1 | Compressor, R-134A | Tecumseh Products | COMPR-110V/50HZ |
| | | | Tecumseh Products | * COMPR-220V/50HZ |
| CON | 1 | Condenser, R-134A | Custom Coil | BT-COND |
| EX1 | 1 | Exchanger, Heat | Thunder | D92A25018 |
| FD | 1 | Filter/Drier | Sporlan-Parker | C-032-S |
| SOL2 | 1 | Valve, Solenoid & Coil | KIP Norgren | A2014S50 |
| V3 | 1 | Valve, Expansion | Sporlan-Parker | NIF-1/2-C |
| V4 | 1 | Valve, Expansion | Sporlan-Parker | NIJ-1/8-C |
| V5 | 1 | Valve, ByPass | Parker | EV-104 |

| | |
|---------------------------|---------------------------------------|
| 5.6 PNEUMATIC CART | Reference Drawings 91S25921, 98D25919 |
|---------------------------|---------------------------------------|

| Find# | Qty. | Description | Mfg. | Part Number |
|--------|------|---------------------------|-------------------|--------------------------|
| ACS | 1 | Enclosure, Air Comp. Sys. | Thunder | **** ACS2520-115 or -230 |
| AH1 | 1 | Hose, Air, 12.5" | Thunder | D92A25067 |
| AH2 | 1 | Hose, Air, 14.5" | Thunder | D92A25066 |
| AH25 | 1 | Hose, Air, 25' | Thunder | D92A25046 |
| AT1 | 1 | Tank, Pressure | Thunder | D98A25038 |
| BV1 &2 | 2 | Valve, Ball | Dynaquip Controls | G5X713 |
| DV | 1 | Valve, Drain | Swagelok | B2P4T2 |
| FQC | 1 | Connector, Female | Hansen - Eaton | B2-H16 |
| F1 | 1 | Filter, Air | Norgren | F73G2ANQD1 |
| F2 | 1 | Filter, Oil Removal | Norgren | F73C2ANQD0 |
| G1 | 1 | Gauge, Pressure | Grainger | G2A148 |
| MQC | 1 | Connector, Male | Hansen - Eaton | B2-K16 |
| REG | 1 | Regulator, Pressure | Norgren | R73G2AKRSN |
| RV1 | 1 | Valve, Relief | Control Devices | G5A710 |

| | |
|-------------------------------|---------------------------|
| 5.7 AIR BOX ELECTRICAL | Reference Drawing ACS2031 |
|-------------------------------|---------------------------|

| Find# | Qty. | Description | Mfg. | Part Number |
|---------|------|-------------------------|----------------------|---------------|
| CBS1 | 1 | Switch, Circuit Breaker | Carling Technologies | ACSPWRSW-1 |
| | | | | * PWRSW-2P |
| CF1&2 | 2 | Fan, Console | Comair Rotron | MR2B3 |
| | | | | * MR77B3 |
| COMP1&2 | 2 | Compressor, Air | Gast Manufacturing | DACS2022 |
| | | | | * DACS2022 |
| HM1 | 1 | Hour Meter, 24VDC | Curtis Instruments | HRMETERACS |
| HLS | 1 | Switch, Heat Limit | Selco | CAP-MR-140-SS |
| SOL1 | 1 | Valve, Solenoid | KIP Norgren | U147121-110 |
| | | | | * U147121-220 |

5.8 OPTION INDICATORS

Asterisk Indicates Optional Parts

- * High Voltage (HV) Option Parts
- ** 50 Hz Option Parts
- *** 2500ST Parts
- **** Air Compressor System Enclosure (ACS) Option
- ***** High Flow (HAF) Option

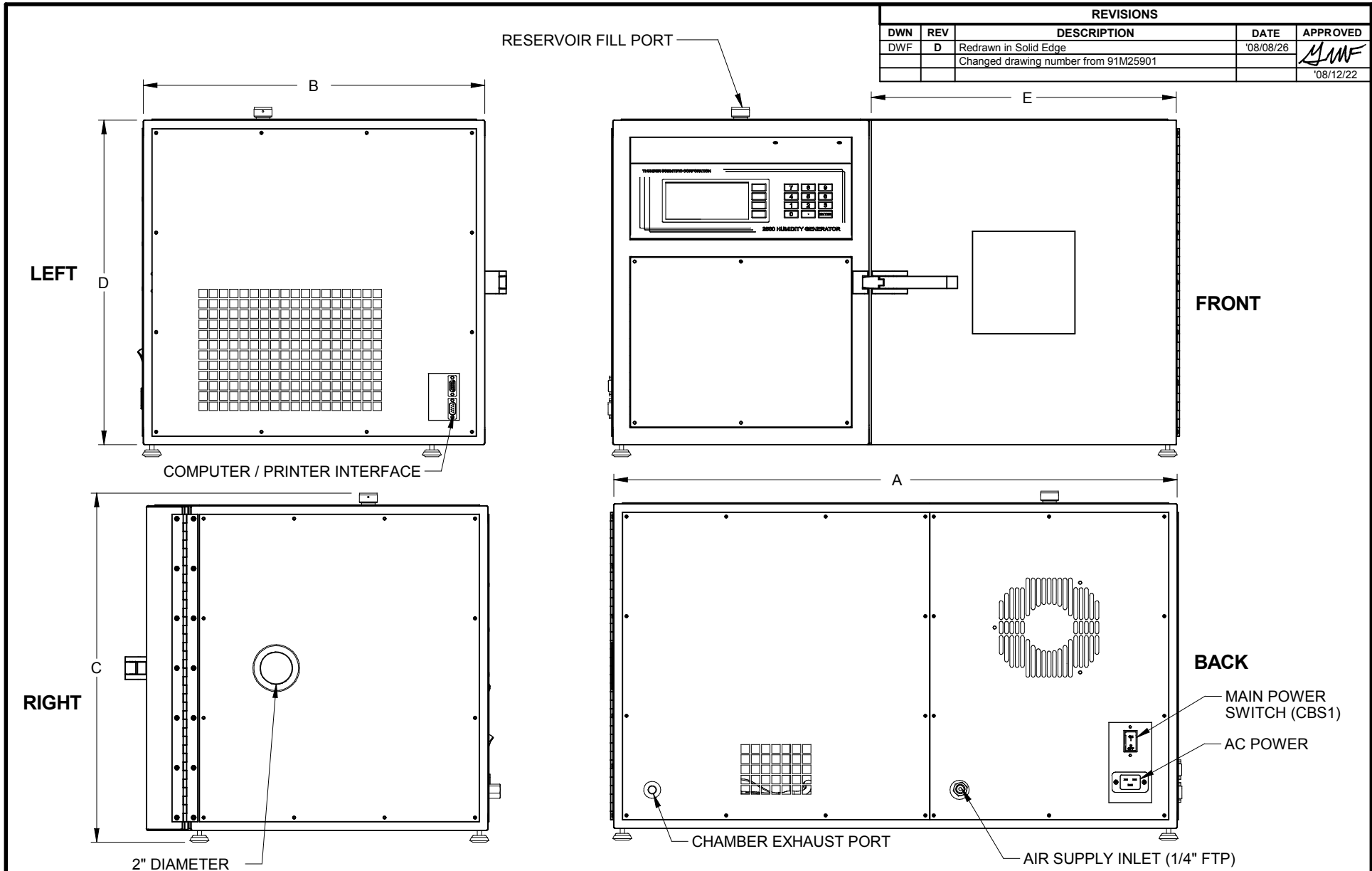

| REVISIONS | | | | |
|-----------|-----|--------------------------------------|-----------|------------|
| DWN | REV | DESCRIPTION | DATE | APPROVED |
| DWF | D | Redrawn in Solid Edge | '08/08/26 | <i>LMF</i> |
| | | Changed drawing number from 91M25901 | | |
| | | | | 08/12/22 |

| DIMENSIONS | | | | | |
|------------|--------|--------|--------|--------|--------|
| MODEL | A | B | C | D | E |
| 2500 R | 33.00" | 20.00" | 20.45" | 19.00" | 18.00" |
| | 838 mm | 508 mm | 519 mm | 514 mm | 457 mm |
| 2500 ST | 36.00" | 23.00" | 23.45" | 22.00" | 21.00" |
| | 914 mm | 584 mm | 595 mm | 591 mm | 533 mm |

| | | | | | |
|---|--------------------------------------|---|---|--|---|
| PROPRIETARY NOTICE: This Drawing and Information Contained Within is Proprietary to Thunder Scientific and cannot be Copied or Reproduced without Written Permission | | TOLERANCES .X ± .015 .XX ± .010 .XXX ± .005 / ±/-.50" <small>UNLESS OTHERWISE SPECIFIED</small> | PRODUCTION DESIGNATION 25-Z-1 | THIRD ANGLE PROJECTION | Thunder Scientific Corporation 623 Wyoming S.E. Albuquerque, NM 87123-3198 |
| NEXT ASSY USED ON APPLICATION | 2500 USED ON FINISH SEE NOTE 7 | TREATMENT NOTE 6 | DRAWN Trissell CHECKED <i>MB</i> ISSUED <i>MB</i> | DATE '91/06/01 '91/06/01 '91/06/01 | Layout, Mechanical / Utility DWG SIZE A DWG NO. 91D25901 REV D SCALE 1 : 10 WEIGHT SHEET 1 OF 1 |

| REVISIONS | | | | |
|-----------|-----|--------------------------------------|-----------|------------|
| DWN | REV | DESCRIPTION | DATE | APPROVED |
| DWF | C | Redrawn in Solid Edge | '09/02/03 | <i>JMF</i> |
| | | Changed drawing number from 91A25902 | | |
| | | | | 09/02/13 |

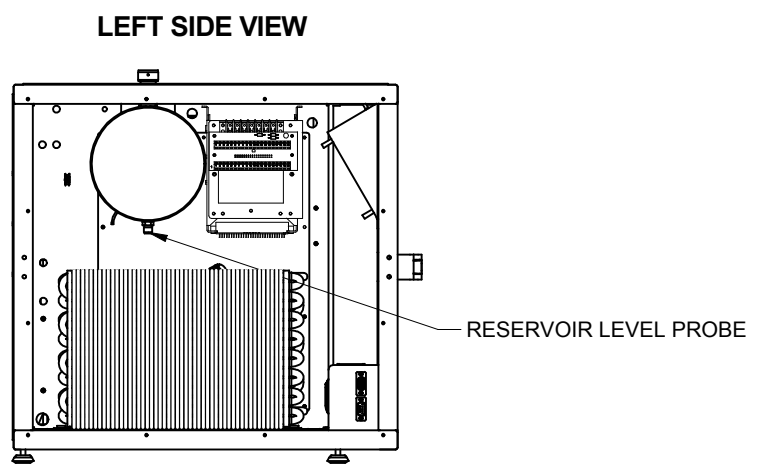
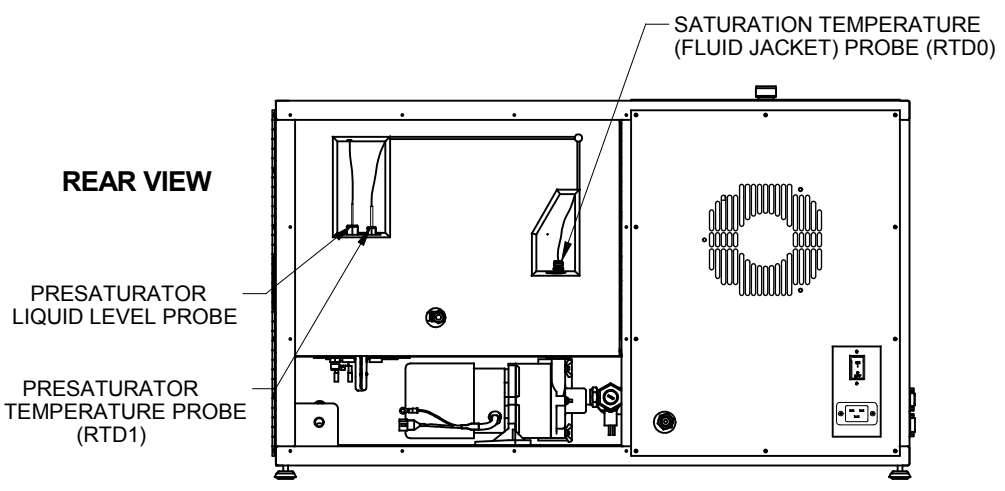
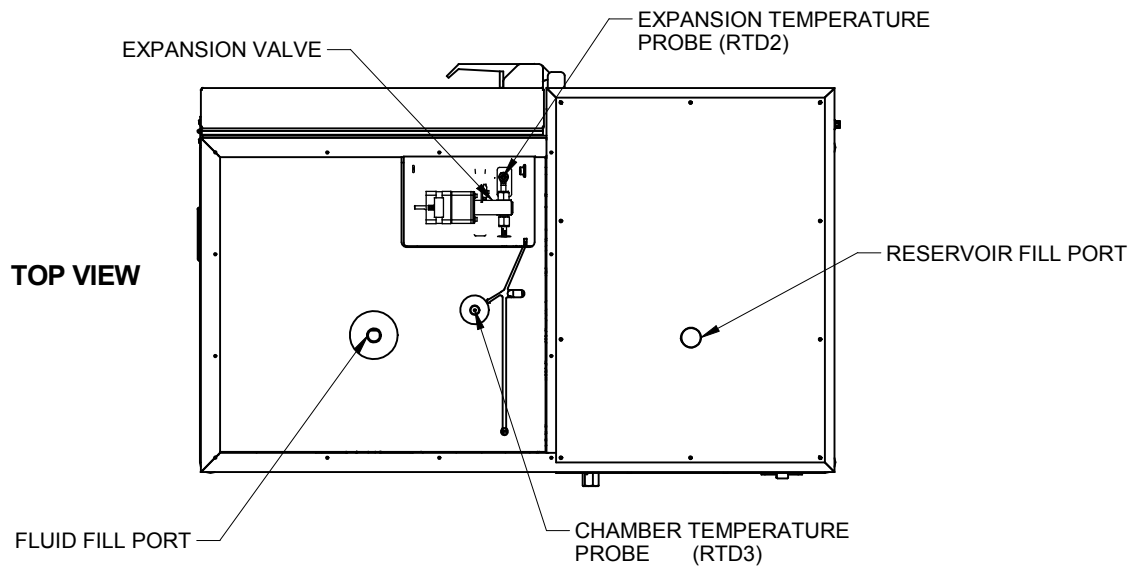

| | | | | |
|----------------------------|---------|--|-------------------------------|---|
| PROPRIETARY NOTICE: | | This Drawing and Information Contained Within is Proprietary to Thunder Scientific and cannot be Copied or Reproduced without Written Permission | | |
| | | TOLERANCES | PRODUCTION DESIGNATION | THIRD ANGLE PROJECTION |
| | | .X ± .015 | 25-Z-2 | |
| | | .XX ± .010 | DRAWN Long | DATE '91/06/01 |
| | | .XXX ± .005 | CHECKED <i>MB</i> | '91/06/01 |
| | 2500 | UNLESS OTHERWISE SPECIFIED | ISSUED <i>MB</i> | '91/06/01 |
| NEXT ASSY | USED ON | TREATMENT NOTE 6 | | DWG SIZE A DWG NO. 91D25902 REV C |
| APPLICATION | FINISH | SEE NOTE 7 | SCALE 1:10 | WEIGHT SHEET 1 OF 1 |

| REVISIONS | | | | |
|-----------|------|---------------------------------------|----------|----------|
| DWN | REV. | DESCRIPTION | DATE | APPROVED |
| DWF | D | Added Card Cage Callout - Drawn to SW | 7/1/2013 | |

TOP VIEW

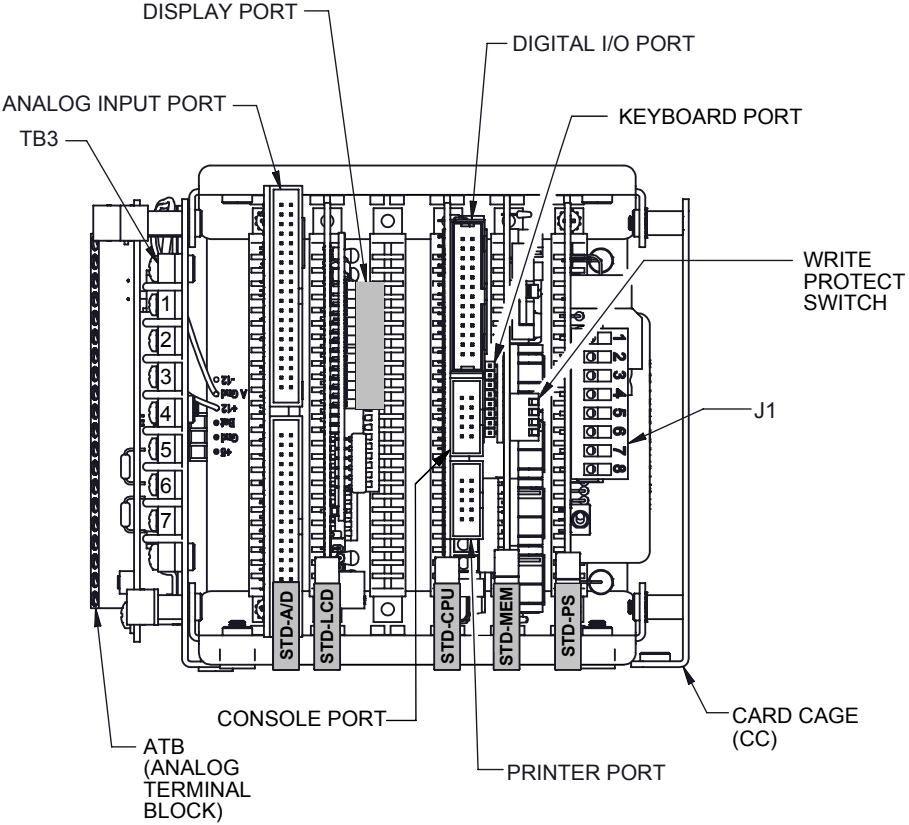
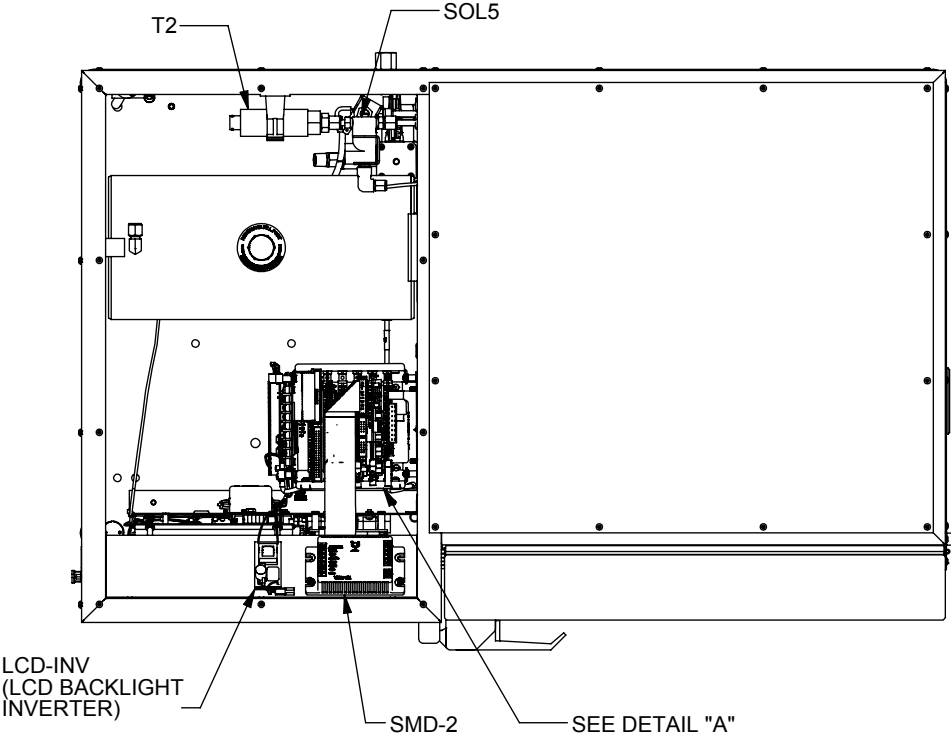

DETAIL "A"
1 : 2

| | | | | | | | | | | |
|-------------|---------|--|----------------------------|---|-----------|---|------------|------------------|-----------------------------|-----------------|
| | | PRODUCTION DESIGNATION 25-Z-3 | THIRD ANGLE PROJECTION | PROPRIETARY NOTICE THIS DRAWING AND INFORMATION CONTAINED WITHIN IS PROPRIETARY TO THUNDER SCIENTIFIC AND CANNOT BE COPIED OR REPRODUCED WITHOUT WRITTEN PERMISSION | | Thunder Scientific Corporation 623 Wyoming S.E. Albuquerque, NM 87123 | | | | |
| | | TOLERANCES .X ±.015 .XX ±.010 .XXX ±.005 ∠ ±.50° UNLESS NOTED OTHERWISE | | DRAWN | LONG | 6/1/1991 | | SIZE A | DWG. NO. 91D25903 | REV D |
| NEXT ASSY | USED ON | 2500 | CHECKED | <i>MB</i> | 6/1/1991 | | SCALE: N/A | | | |
| APPLICATION | | | | ISSUED | <i>MB</i> | 6/1/1991 | | | | |

| REVISIONS | | | | |
|-----------|------|-------------------------|-----------|----------|
| DWN | REV. | DESCRIPTION | DATE | APPROVED |
| DWF | G | Added FS1 - Drawn to SW | 6/27/2013 | |

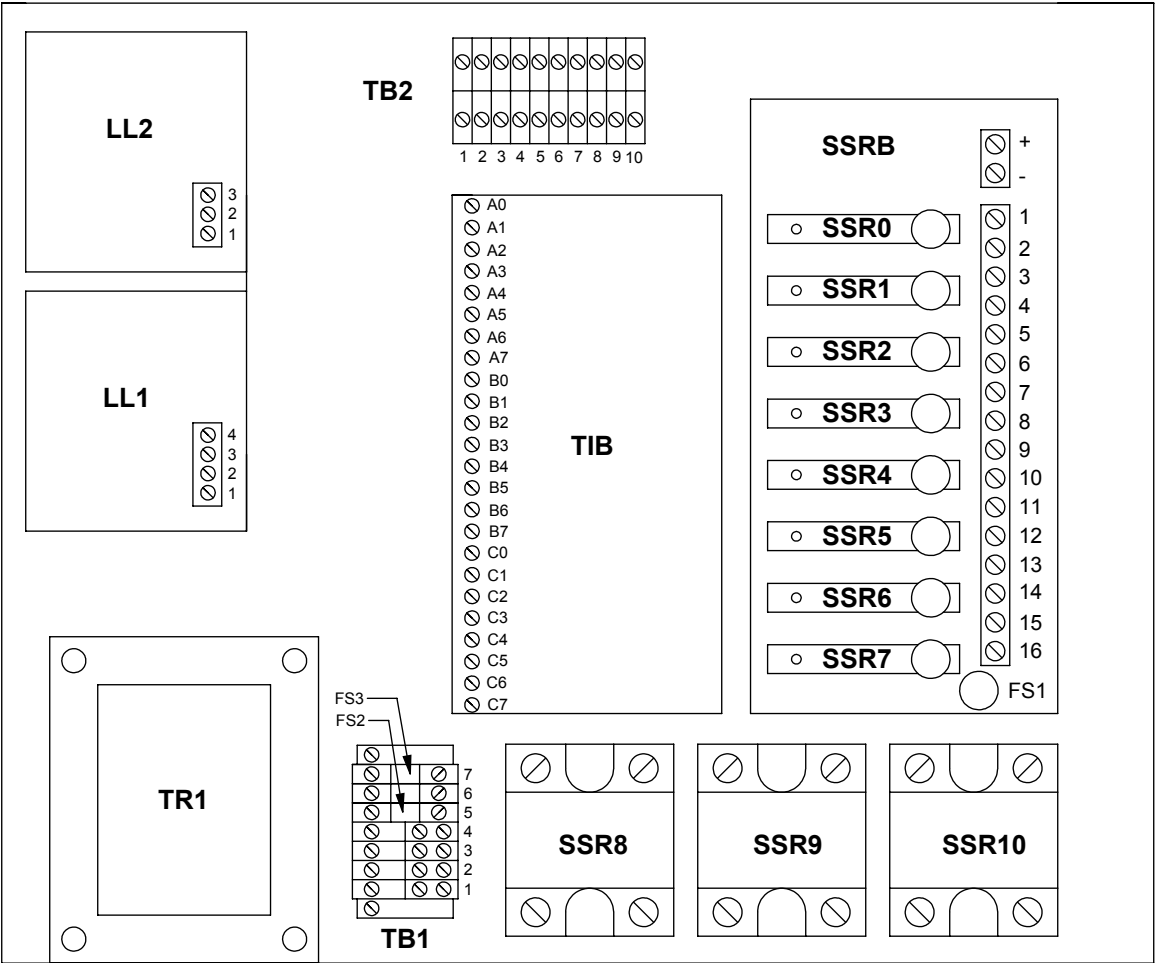

| | | | | | | | | | |
|-------------------|--|---|----------------------------|---|------------------------------------|---|---------------|--------------------------|--------------|
| | | PRODUCTION DESIGNATION 25-Z-4 | THIRD ANGLE PROJECTION | PROPRIETARY NOTICE THIS DRAWING AND INFORMATION CONTAINED WITHIN IS PROPRIETARY TO THUNDER SCIENTIFIC AND CANNOT BE COPIED OR REPRODUCED WITHOUT WRITTEN PERMISSION | | Thunder Scientific Corporation 623 Wyoming S.E. Albuquerque, NM 87123 | | | |
| | | TOLERANCES .X ±.015 .XX ±.010 .XXX ±.005 ∠ ±.50° UNLESS NOTED OTHERWISE | | DRAWN LONG 6/1/1991 CHECKED <i>MB</i> 6/1/1991 ISSUED <i>MB</i> 6/1/1991 | Electrical Sub Panel Layout | | SIZE A | DWG. NO. 91D25904 | REV G |
| NEXT ASSY USED ON | | 2500 | | | SCALE N/A | WT. N/A | SHEET 1 OF 1 | | |
| APPLICATION | | | | | | | | | |

| REVISIONS | | | | |
|-----------|------|-------------|-----------|----------|
| DWN | REV. | DESCRIPTION | DATE | APPROVED |
| DWF | F | Drawn to SW | 7/25/2014 | |

LOW VOLTAGE CONFIGURATION

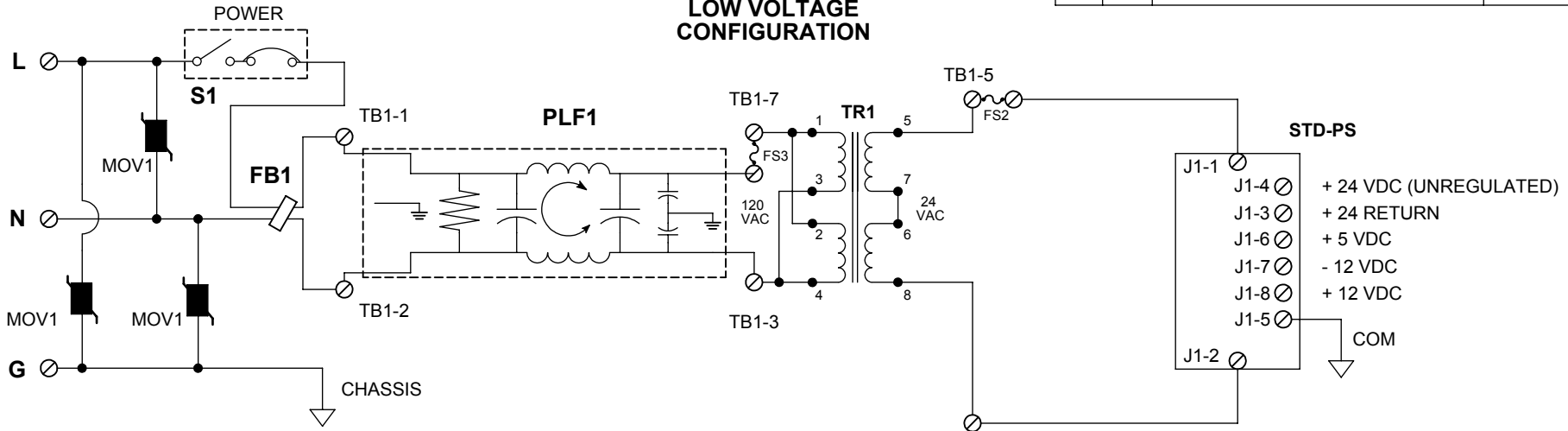

HIGH VOLTAGE CONFIGURATION

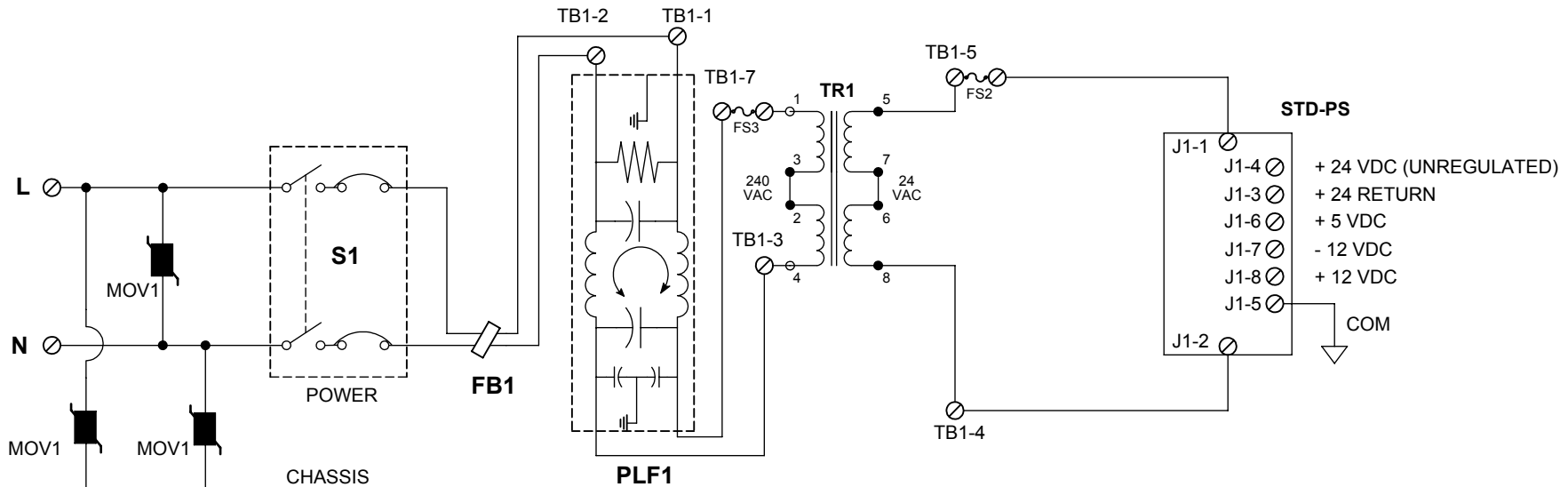

| | | | | | | | |
|-------------|--|----------------------------|--|--------------|---|--------------|--|
| | | THIRD ANGLE PROJECTION | PROPRIETARY NOTICE THIS DRAWING AND INFORMATION CONTAINED WITHIN IS PROPRIETARY TO THUNDER SCIENTIFIC AND CANNOT BE COPIED OR REPRODUCED WITHOUT SPECIFIC WRITTEN PERMISSION | | Thunder Scientific Corporation 623 Wyoming S.E. Albuquerque, NM 87123 | | |
| | | TOLERANCES | DRAWN | Long | 6/1/1991 | | |
| NEXT ASSY | | .XXX ±.010 | CHECKED | <i>MG</i> | 6/1/1991 | | |
| USED ON | | UNLESS NOTED OTHERWISE | ISSUED | <i>MG</i> | 6/1/1991 | | |
| APPLICATION | | | | SIZE | DWG. NO. | REV | |
| | | | | A | 91S25906 | F | |
| | | | | SCALE: 1 : 1 | WT. N/A | SHEET 1 OF 1 | |

REVISIONS

| DWN | REV. | DESCRIPTION | DATE | APPROVED |
|-----|------|-------------|-----------|----------|
| DWF | D | Drawn to SW | 7/25/2014 | |

SSRB

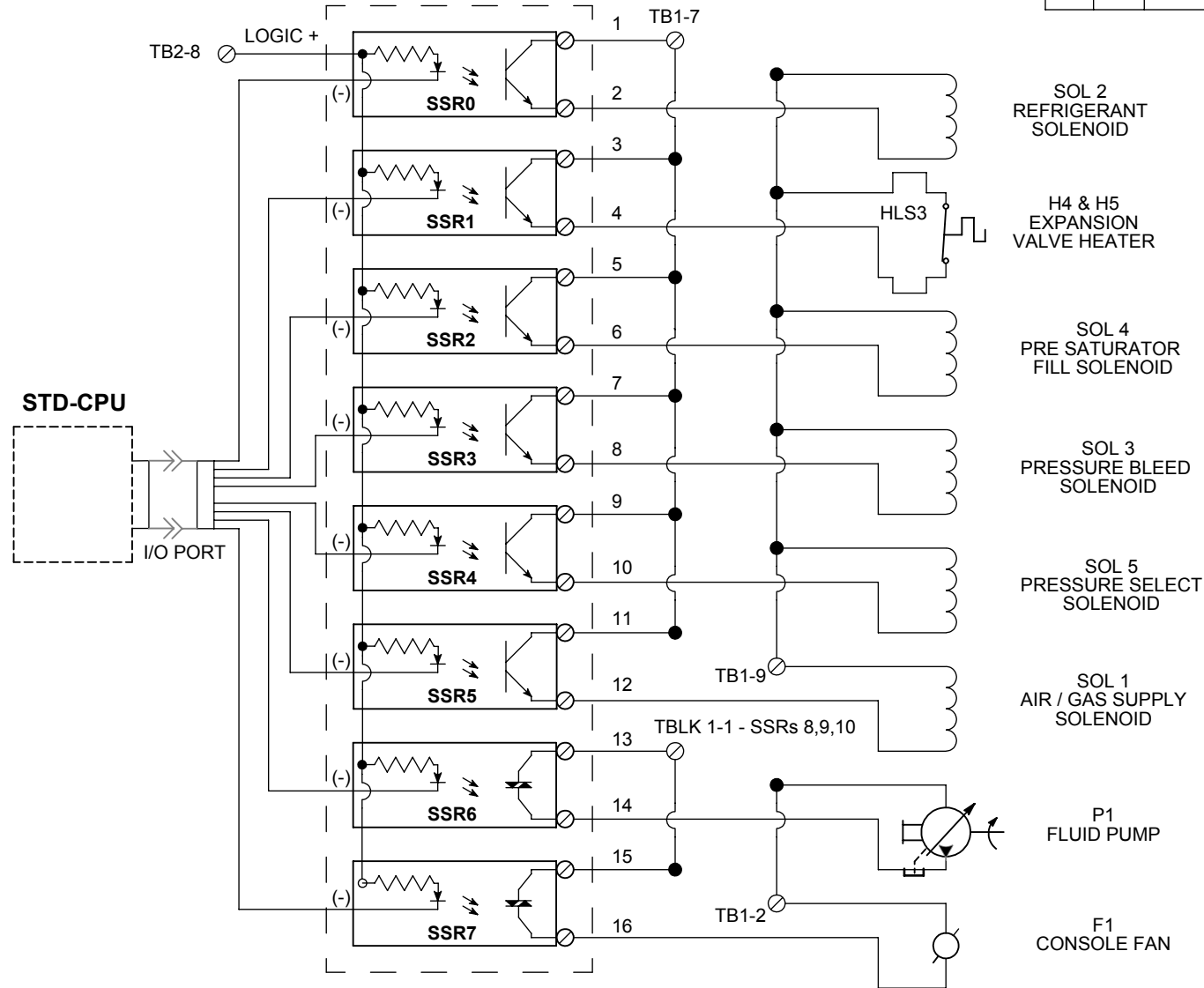

STD-CPU

I/O PORT

TB2-8 LOGIC +

1 TB1-7

SSR0

2

SSR1

3

SSR2

4

SSR3

5

SSR4

6

SSR5

7

SSR6

8

SSR7

9

10 TB1-9

11 TB1-9

12 TB1-9

13 TB1-9

14 TB1-9

15 TB1-9

16 TB1-9

17 TB1-9

18 TB1-9

19 TB1-9

20 TB1-9

21 TB1-9

22 TB1-9

23 TB1-9

24 TB1-9

25 TB1-9

26 TB1-9

27 TB1-9

28 TB1-9

29 TB1-9

30 TB1-9

31 TB1-9

32 TB1-9

33 TB1-9

34 TB1-9

35 TB1-9

SOL 2
REFRIGERANT
SOLENOID

H4 & H5
EXPANSION
VALVE HEATER

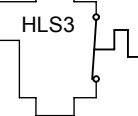

SOL 4
PRE SATURATOR
FILL SOLENOID

SOL 3
PRESSURE BLEED
SOLENOID

SOL 5
PRESSURE SELECT
SOLENOID

SOL 1
AIR / GAS SUPPLY
SOLENOID

P1
FLUID PUMP

F1
CONSOLE FAN

THIRD ANGLE
PROJECTION

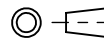

PROPRIETARY NOTICE

THIS DRAWING AND INFORMATION CONTAINED
WITHIN IS PROPRIETARY TO THUNDER SCIENTIFIC
AND CANNOT BE COPIED OR REPRODUCED WITHOUT
SPECIFIC WRITTEN PERMISSION

Thunder Scientific Corporation

623 Wyoming S.E. Albuquerque, NM 87123

Solid State Relay Module Board

| | |
|-------------|---------|
| | |
| | 2500 |
| NEXT ASSY | USED ON |
| APPLICATION | |

TOLERANCES

.XXX ±.010

±.50°

UNLESS NOTED OTHERWISE

| | | |
|---------|------|----------|
| DRAWN | Long | 6/1/1991 |
| CHECKED | MG | 6/1/1991 |
| ISSUED | MG | 6/1/1991 |

| | | |
|--------------|----------|--------------|
| SIZE | DWG. NO. | REV |
| A | 91S25907 | D |
| SCALE: 1 : 1 | WT. N/A | SHEET 1 OF 1 |

| REVISIONS | | | | |
|-----------|------|-------------|-----------|----------|
| DWN | REV. | DESCRIPTION | DATE | APPROVED |
| DWF | D | Drawn to SW | 7/28/2014 | |

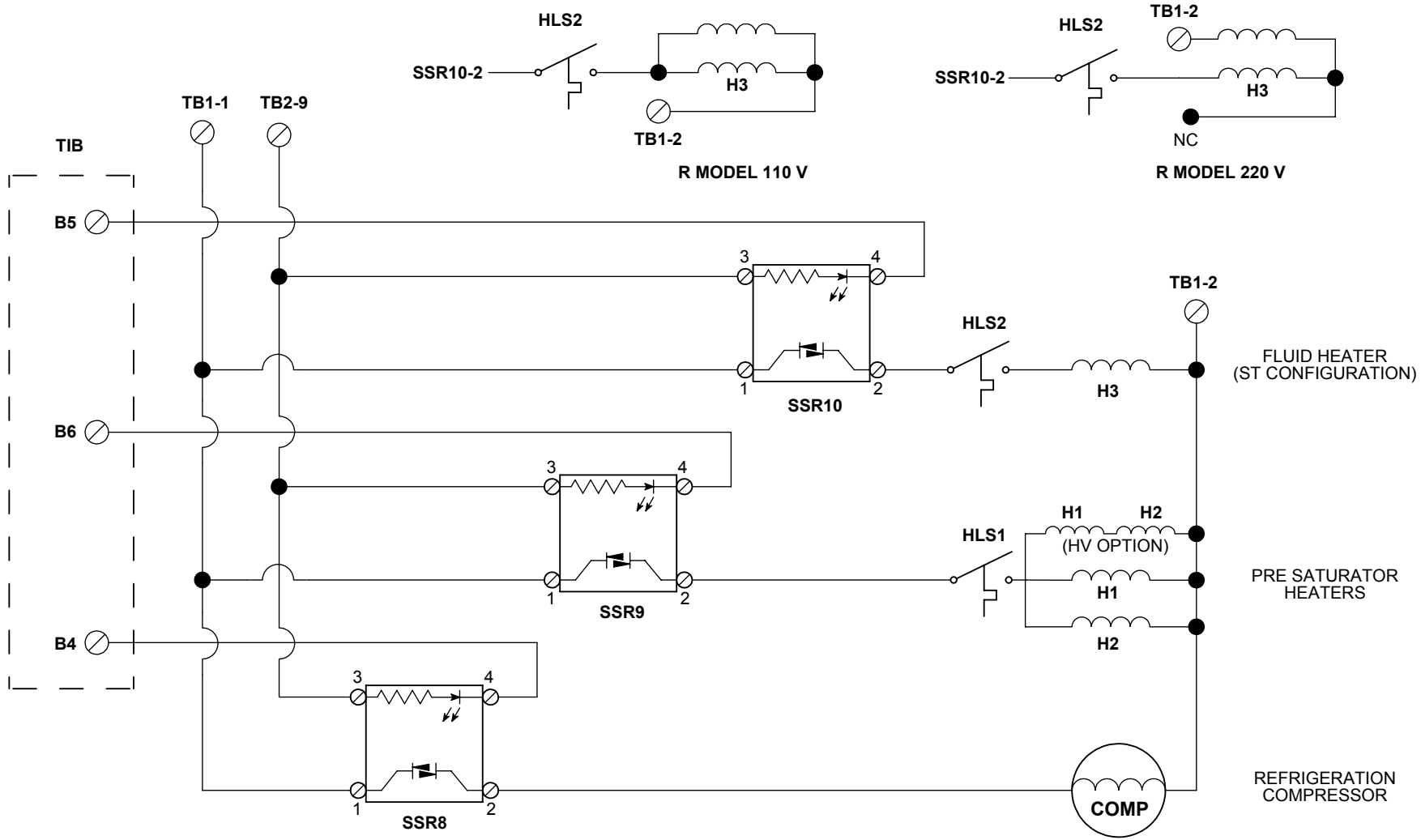

| | | | | | | | |
|-----------|---------|--|--|--|---|-------------------------------------|------------------------------|
| | | THIRD ANGLE PROJECTION | PROPRIETARY NOTICE THIS DRAWING AND INFORMATION CONTAINED WITHIN IS PROPRIETARY TO THUNDER SCIENTIFIC AND CANNOT BE COPIED OR REPRODUCED WITHOUT SPECIFIC WRITTEN PERMISSION | | Thunder Scientific Corporation 623 Wyoming S.E. Albuquerque, NM 87123 | | |
| | | | | | Compressor / Heater Schematic | | |
| | 2500 | TOLERANCES .XXX ±.010 ∠ ±.50° UNLESS NOTED OTHERWISE | | DRAWN Long 6/1/1991 CHECKED <i>MB</i> 6/1/1991 ISSUED <i>MB</i> 6/1/1991 | SIZE A SCALE: 1 : 1 | DWG. NO. 91S25908 WT. N/A | REV D SHEET 1 OF 1 |
| NEXT ASSY | USED ON | APPLICATION | | | | | |

| REVISIONS | | | | |
|-----------|------|-------------|-----------|----------|
| DWN | REV. | DESCRIPTION | DATE | APPROVED |
| DWF | F | Drawn to SW | 7/28/2014 | <i>F</i> |

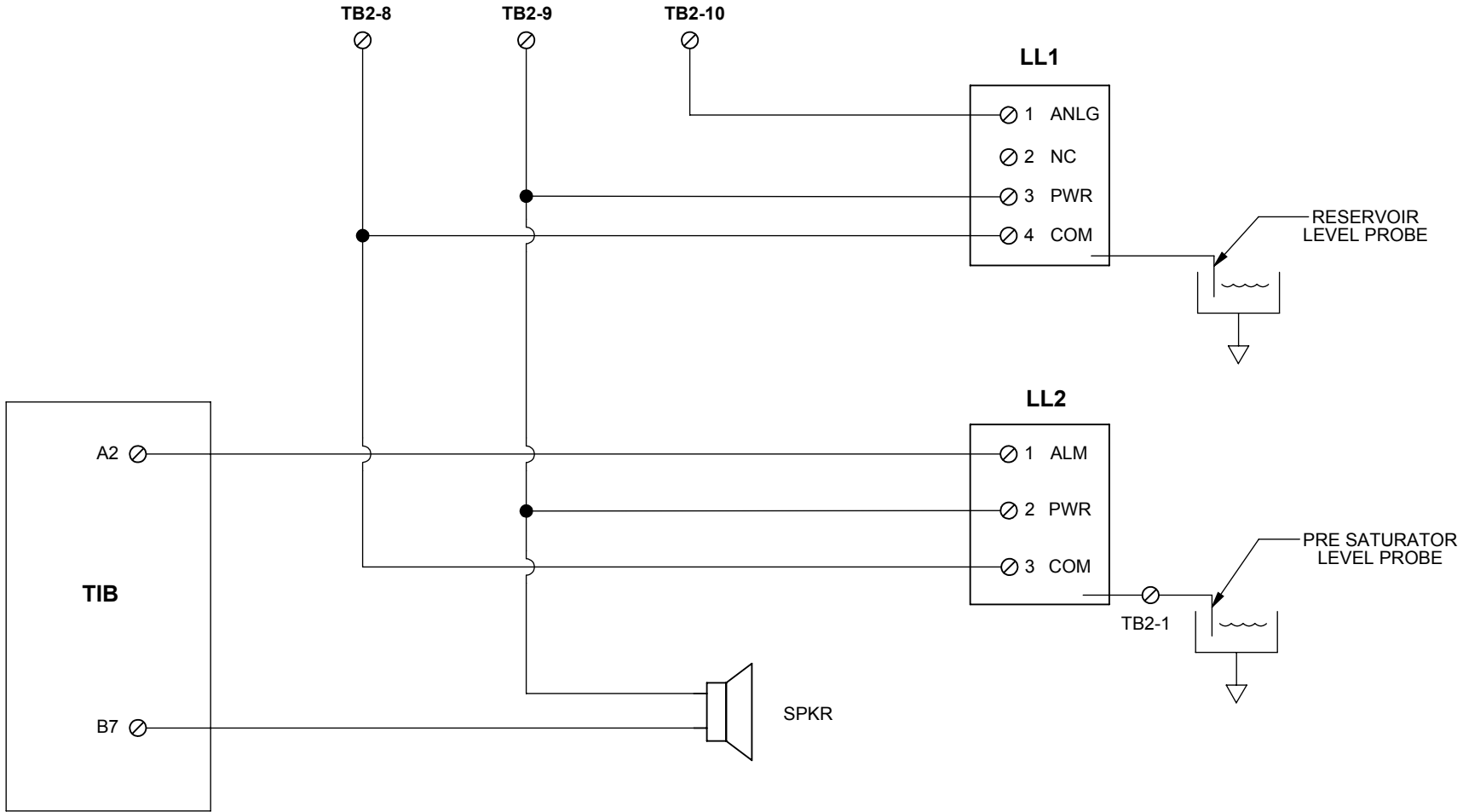

| | | | | | | | |
|-------------|---------|--|--|--|---|--------------|--|
| | | THIRD ANGLE PROJECTION | PROPRIETARY NOTICE THIS DRAWING AND INFORMATION CONTAINED WITHIN IS PROPRIETARY TO THUNDER SCIENTIFIC AND CANNOT BE COPIED OR REPRODUCED WITHOUT SPECIFIC WRITTEN PERMISSION | | Thunder Scientific Corporation 623 Wyoming S.E. Albuquerque, NM 87123 | | |
| | | | | | Liquid Level / Speaker Schematic | | |
| | 2500 | TOLERANCES .XXX ±.010 ±.50° UNLESS NOTED OTHERWISE | | DRAWN Long 6/1/1991 CHECKED <i>MG</i> 6/1/1991 ISSUED <i>MG</i> 6/1/1991 | SIZE A DWG. NO. 91S25909 | REV F | |
| NEXT ASSY | USED ON | | | SCALE: 1 : 1 | WT. N/A | SHEET 1 OF 1 | |
| APPLICATION | | | | | | | |

| REVISIONS | | | | |
|-----------|------|-------------|-----------|----------|
| DWN | REV. | DESCRIPTION | DATE | APPROVED |
| DWF | D | Drawn to SW | 7/28/2014 | |

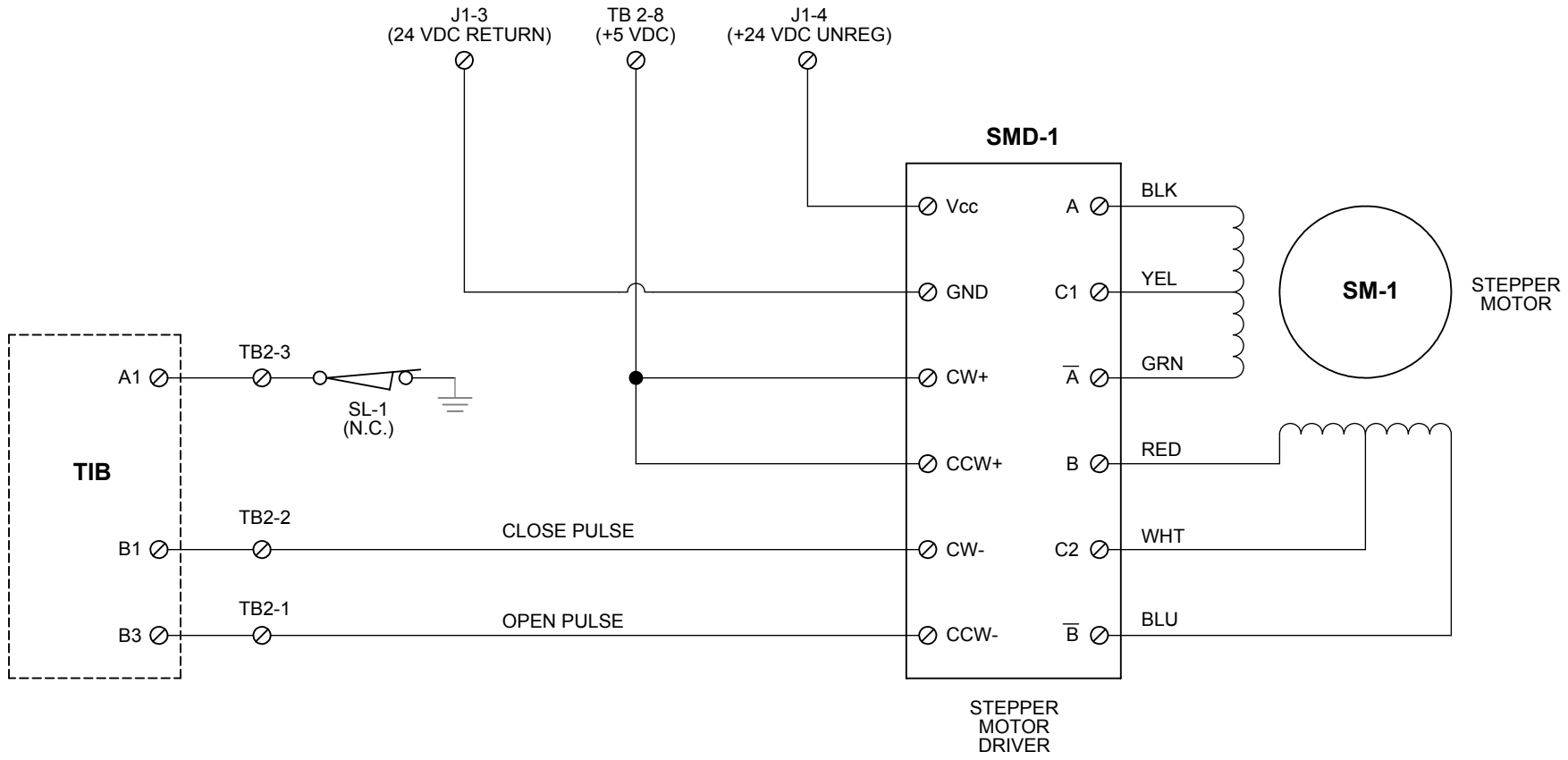

| | | | | | | | |
|-----------|---------|--|--|--|---|---------|------------------------------|
| | | THIRD ANGLE PROJECTION | PROPRIETARY NOTICE THIS DRAWING AND INFORMATION CONTAINED WITHIN IS PROPRIETARY TO THUNDER SCIENTIFIC AND CANNOT BE COPIED OR REPRODUCED WITHOUT SPECIFIC WRITTEN PERMISSION | | Thunder Scientific Corporation 623 Wyoming S.E. Albuquerque, NM 87123 | | |
| | | | | | Flow Valve (V1) Control Schematic | | |
| | 2500 | TOLERANCES .XXX ±.010 ±.50° UNLESS NOTED OTHERWISE | | DRAWN Long 6/1/1991 CHECKED <i>MG</i> 6/1/1991 ISSUED <i>MG</i> 6/1/1991 | SIZE A DWG. NO. 91S25910 SCALE: 1 : 1 | WT. N/A | REV D SHEET 1 OF 1 |
| NEXT ASSY | USED ON | APPLICATION | | | | | |

| REVISIONS | | | | |
|-----------|------|-------------|-----------|----------|
| DWN | REV. | DESCRIPTION | DATE | APPROVED |
| DWF | C | Drawn to SW | 7/28/2014 | |

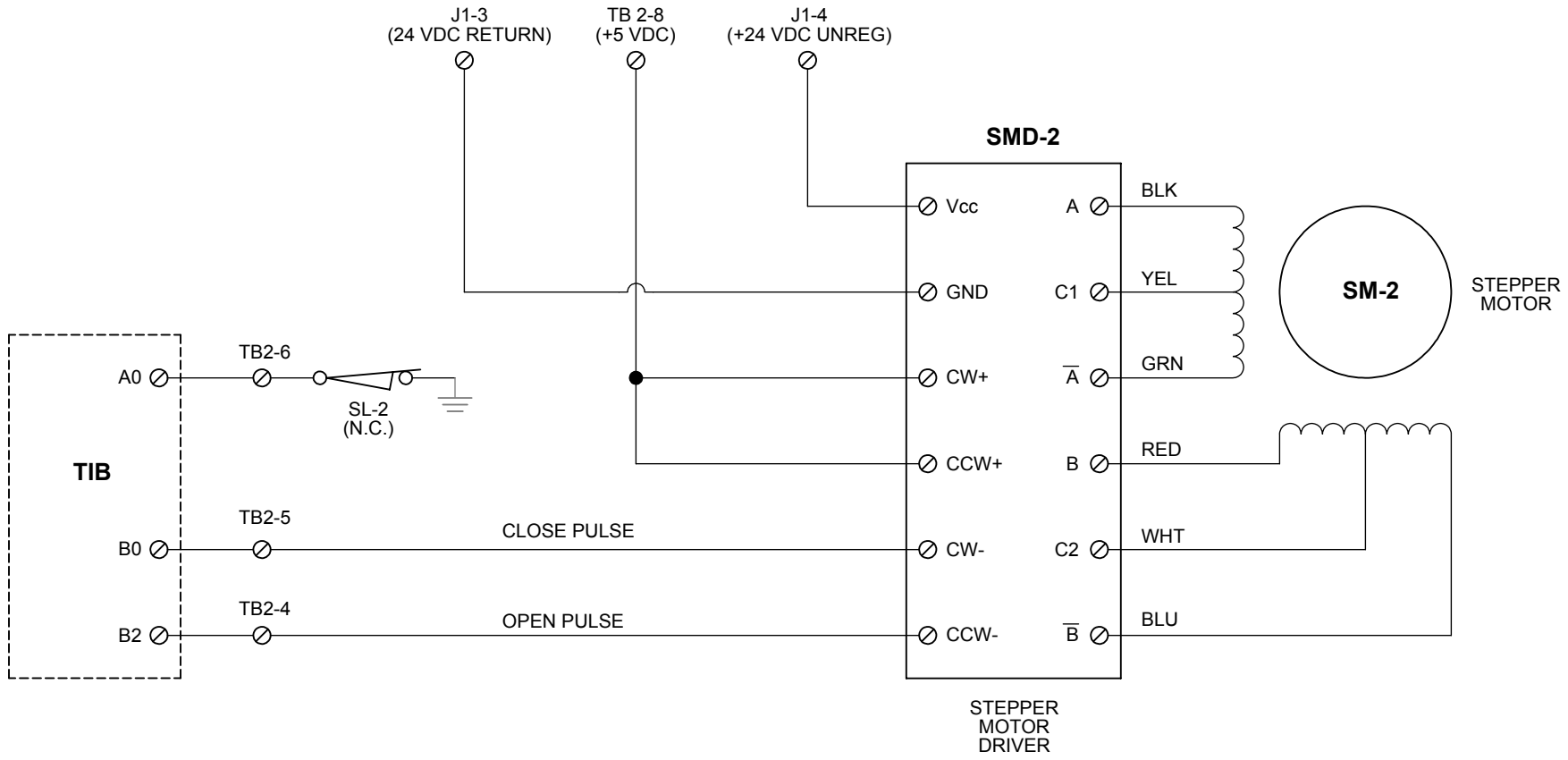

| | | | | | | | |
|-------------|------|--|--|--|---|--------------|--|
| | | THIRD ANGLE PROJECTION | PROPRIETARY NOTICE THIS DRAWING AND INFORMATION CONTAINED WITHIN IS PROPRIETARY TO THUNDER SCIENTIFIC AND CANNOT BE COPIED OR REPRODUCED WITHOUT SPECIFIC WRITTEN PERMISSION | | Thunder Scientific Corporation 623 Wyoming S.E. Albuquerque, NM 87123 | | |
| | | | | | Exp. Valve (V2) Control Schematic | | |
| | 2500 | TOLERANCES .XXX ±.010 ±.50° UNLESS NOTED OTHERWISE | | DRAWN Long 6/1/1991 CHECKED <i>MG</i> 6/1/1991 ISSUED <i>MG</i> 6/1/1991 | SIZE A DWG. NO. 91S25911 | REV C | |
| APPLICATION | | | | SCALE: 1 : 1 | WT. N/A | SHEET 1 OF 1 | |

| REVISIONS | | | | |
|-----------|------|-------------|-----------|----------|
| DWN | REV. | DESCRIPTION | DATE | APPROVED |
| DWF | D | Drawn to SW | 7/28/2014 | |

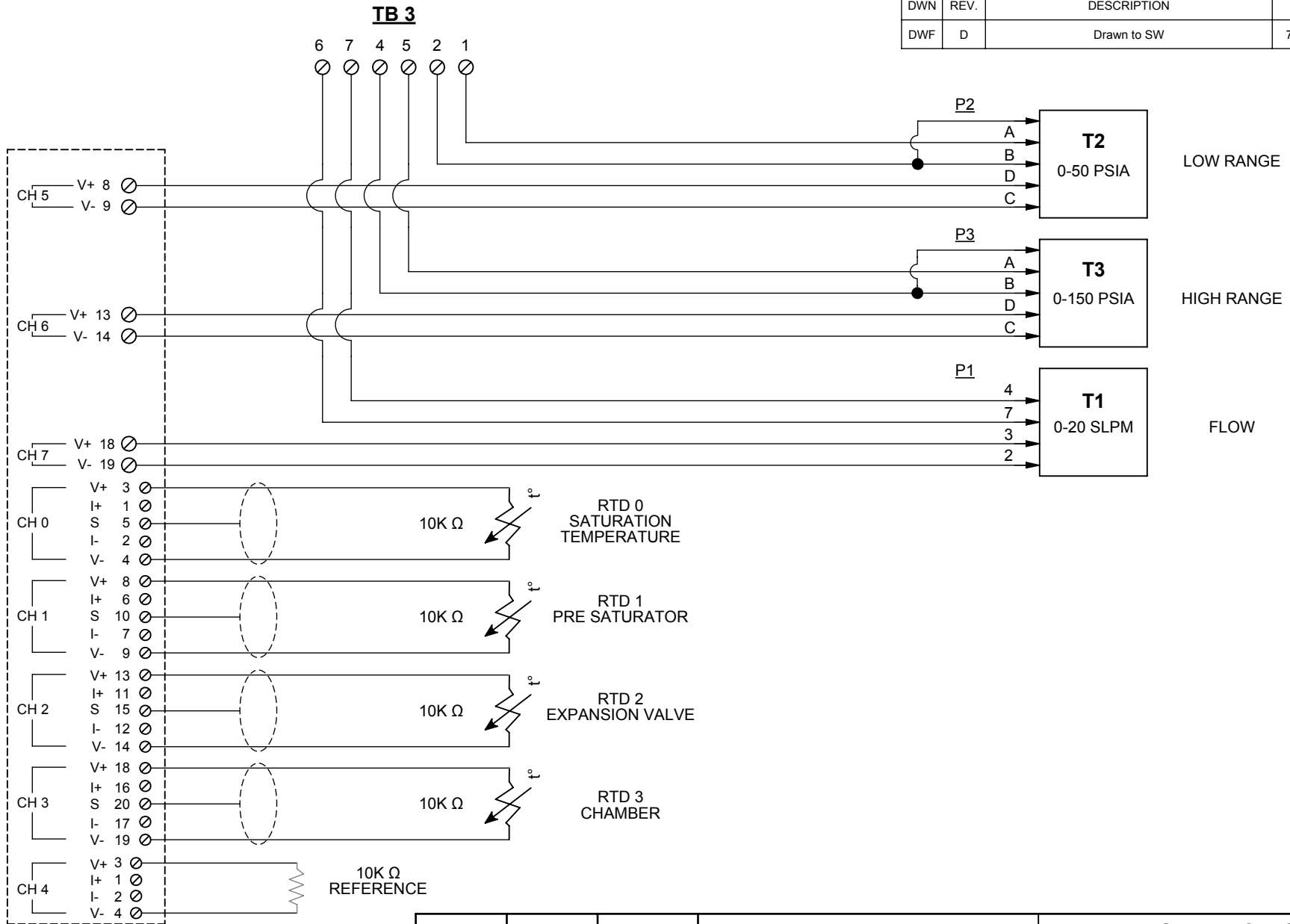

| | |
|-------------|---------|
| | |
| | |
| | |
| | 2500 |
| NEXT ASSY | USED ON |
| APPLICATION | |

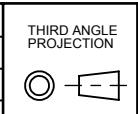

PROPRIETARY NOTICE
THIS DRAWING AND INFORMATION CONTAINED WITHIN IS PROPRIETARY TO THUNDER SCIENTIFIC AND CANNOT BE COPIED OR REPRODUCED WITHOUT SPECIFIC WRITTEN PERMISSION

| | | | | |
|------------------------|-------|---------|-----------|----------|
| TOLERANCES | | DRAWN | Long | 6/1/1991 |
| .XXX | ±.010 | CHECKED | <i>MB</i> | 6/1/1991 |
| | ±.50° | ISSUED | <i>MB</i> | 6/1/1991 |
| UNLESS NOTED OTHERWISE | | | | |

Thunder Scientific Corporation
623 Wyoming S.E. Albuquerque, NM 87123

Temp Probe / Transducer Schematic

| | | |
|--------------|----------|--------------|
| SIZE | DWG. NO. | REV |
| A | 91S25912 | D |
| SCALE: 1 : 1 | WT. N/A | SHEET 1 OF 1 |

| REVISIONS | | | | |
|-----------|------|-------------|-----------|--------------------|
| DWN | REV. | DESCRIPTION | DATE | APPROVED |
| DWF | C | Drawn to SW | 7/28/2014 | <i>[Signature]</i> |

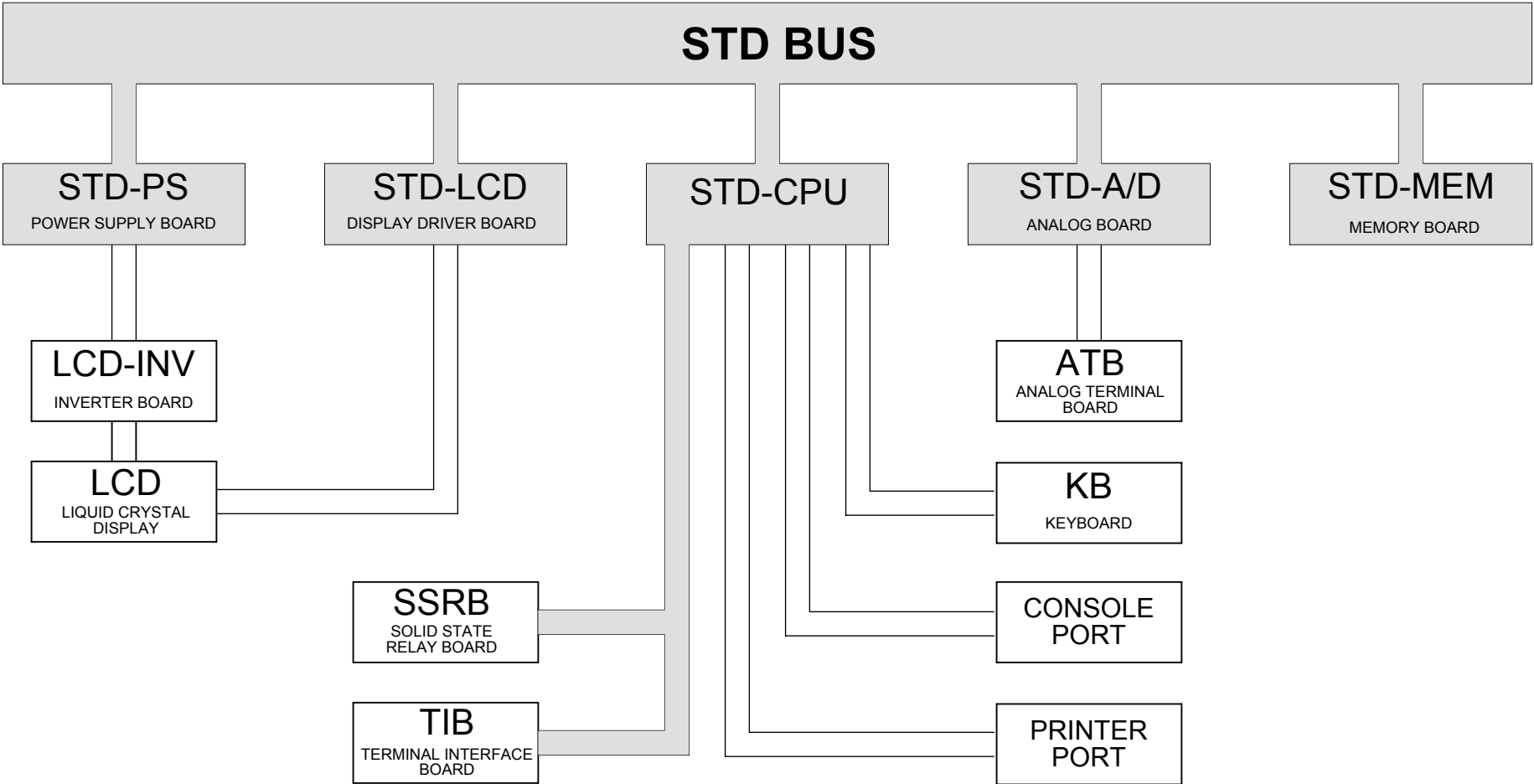

| | | | | | | | |
|-----------|---------|--|--|--|---|---------|------------------------------|
| | | THIRD ANGLE PROJECTION | PROPRIETARY NOTICE THIS DRAWING AND INFORMATION CONTAINED WITHIN IS PROPRIETARY TO THUNDER SCIENTIFIC AND CANNOT BE COPIED OR REPRODUCED WITHOUT SPECIFIC WRITTEN PERMISSION | | Thunder Scientific Corporation 623 Wyoming S.E. Albuquerque, NM 87123 | | |
| | | | | | STD Bus Diagram | | |
| | 2500 | TOLERANCES .XXX ±.010 ±.50° UNLESS NOTED OTHERWISE | | DRAWN Long 6/1/1991 CHECKED <i>MB</i> 6/1/1991 ISSUED <i>MB</i> 6/1/1991 | SIZE A DWG. NO. 91D25913 SCALE: 1 : 1 | WT. N/A | REV C SHEET 1 OF 1 |
| NEXT ASSY | USED ON | APPLICATION | | | | | |

| REVISIONS | | | | |
|-----------|------|-------------|-----------|----------|
| DWN | REV. | DESCRIPTION | DATE | APPROVED |
| DWF | C | Drawn to SW | 7/28/2014 | |

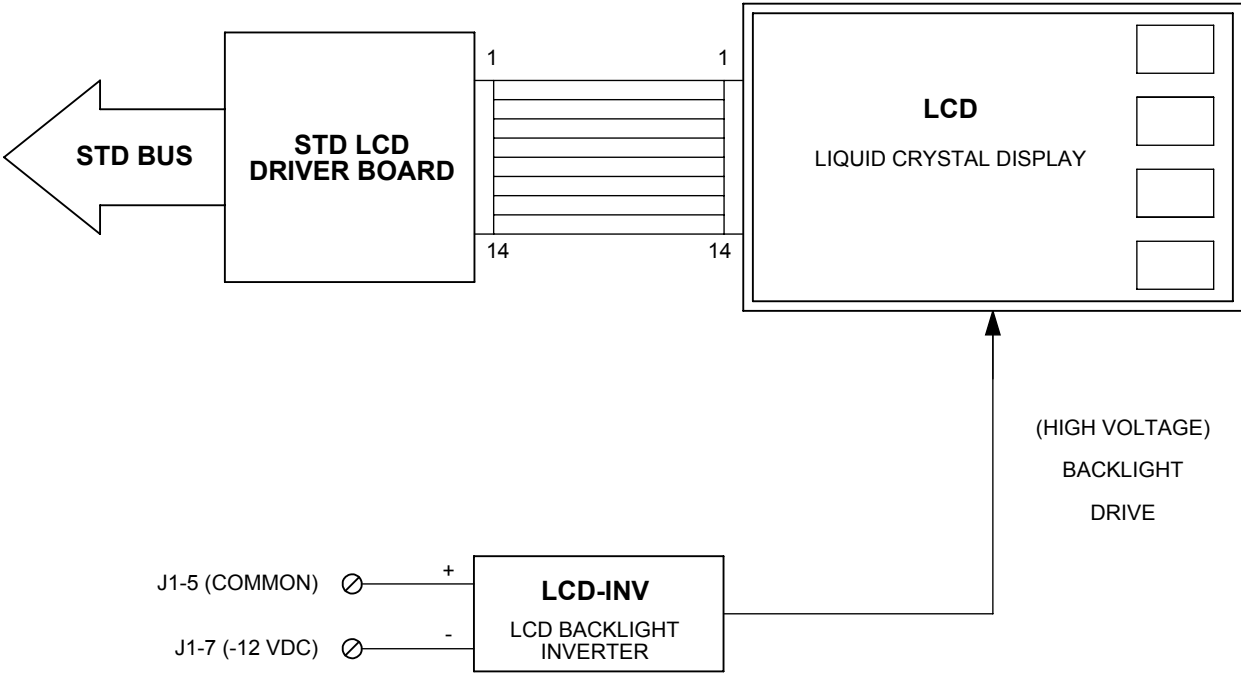

| | | | | | | | | |
|-----------|---------|----------------------------|--|--|---|---------|---|--|
| | | THIRD ANGLE PROJECTION | PROPRIETARY NOTICE THIS DRAWING AND INFORMATION CONTAINED WITHIN IS PROPRIETARY TO THUNDER SCIENTIFIC AND CANNOT BE COPIED OR REPRODUCED WITHOUT SPECIFIC WRITTEN PERMISSION | | Thunder Scientific Corporation 623 Wyoming S.E. Albuquerque, NM 87123 | | | |
| | | | TOLERANCES .XXX ±.010 ±.50° UNLESS NOTED OTHERWISE | | DRAWN Long 6/1/1991 CHECKED <i>MG</i> 6/1/1991 ISSUED <i>MG</i> 6/1/1991 | | Display Block Diagram SIZE A DWG. NO. 91S25914 REV C | |
| NEXT ASSY | USED ON | 2500 | APPLICATION | | SCALE: 1 : 1 | WT. N/A | SHEET 1 OF 1 | |

| REVISIONS | | | | |
|-----------|------|-------------|-----------|----------|
| DWN | REV. | DESCRIPTION | DATE | APPROVED |
| DWF | C | Drawn to SW | 7/28/2014 | |

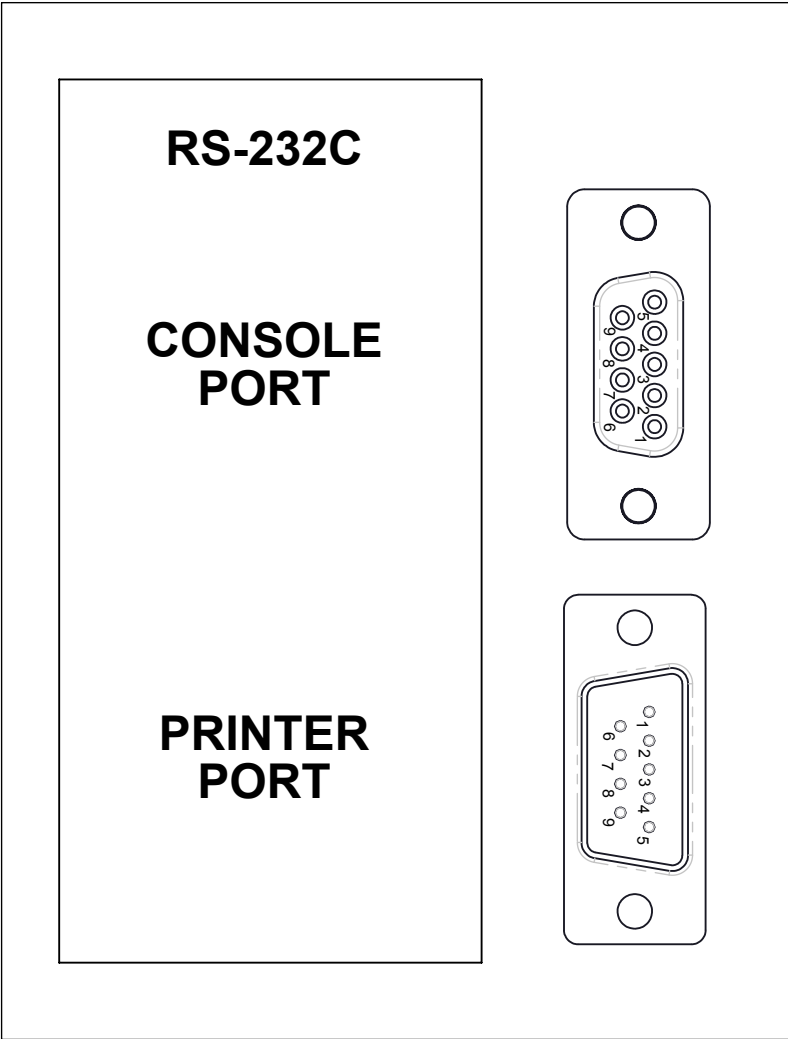

CONNECTOR PINOUT

| PIN # | CONSOLE PORT | PRINTER PORT |
|-------|--------------|--------------|
| 1 | NC | NC |
| 2 | TxD | TxD |
| 3 | RxD | RxD |
| 4 | DSR** | DSR** |
| 5 | SIG GND | SIG GND |
| 6 | DTR** | DTR** |
| 7 | RTS | RTS |
| 8 | CTS* | CTS* |
| 9 | NC | NC |

* = TIED TO +5V VIA 4.7K RESISTOR

** = BENCHTOP DOES NOT SUPPORT DSR & DTR SIGNALS. PINS 4 & 6 ARE STRAPPED TOGETHER WITHIN BENCHTOP FOR THE USE OF PERIPHERAL EQUIPMENT.

PRINTER CONNECTION

TO CONNECT A SERIAL PRINTER TO THE PRINTER PORT, USE PRINTER CABLE (PART #: PCABLE) OR A STANDARD MODEM CABLE

COMPUTER CONNECTION

TO CONNECT ANY IBM COMPATABLE COMPUTER TO THE CONSOLE PORT, USE CONSOLE CABLE (PART #: CCABLE) OR 9 PIN EXTENDER CABLE. CONNECTION TO ANY OLDER COMPUTER MAY REQUIRE AN ADAPTER CABLE OR CONNECTOR. (NOT PROVIDED)

MODEM CONNECTION

TO CONNECT A MODEM TO THE CONSOLE PORT, USE MODEM CABLE (PART #: MCABLE)

THESE CONNECTIONS CAN BE FOUND ON THE LOWER RIGHT HAND CORNER OF THE LEFT SIDE PANEL

| | | | | | | | |
|-------------|---------|--|--|--|---|--------------|--|
| | | THIRD ANGLE PROJECTION | PROPRIETARY NOTICE THIS DRAWING AND INFORMATION CONTAINED WITHIN IS PROPRIETARY TO THUNDER SCIENTIFIC AND CANNOT BE COPIED OR REPRODUCED WITHOUT SPECIFIC WRITTEN PERMISSION | | Thunder Scientific Corporation 623 Wyoming S.E. Albuquerque, NM 87123 | | |
| | | | | | RS-232C / Printer Console | | |
| | 2500 | TOLERANCES .XXX ±.010 ±.50° UNLESS NOTED OTHERWISE | | DRAWN Long 6/1/1991 CHECKED <i>MB</i> 6/1/1991 ISSUED <i>MB</i> 6/1/1991 | SIZE A DWG. NO. 91D25915 | REV C | |
| NEXT ASSY | USED ON | | | SCALE: 1 : 1 | WT. N/A | SHEET 1 OF 1 | |
| APPLICATION | | | | | | | |

| REVISIONS | | | | |
|-----------|------|--------------------------------|-----------|----------|
| DWN | REV. | DESCRIPTION | DATE | APPROVED |
| DWF | C | Changed CV1 to PT1 Drawn to SW | 6/27/2013 | |

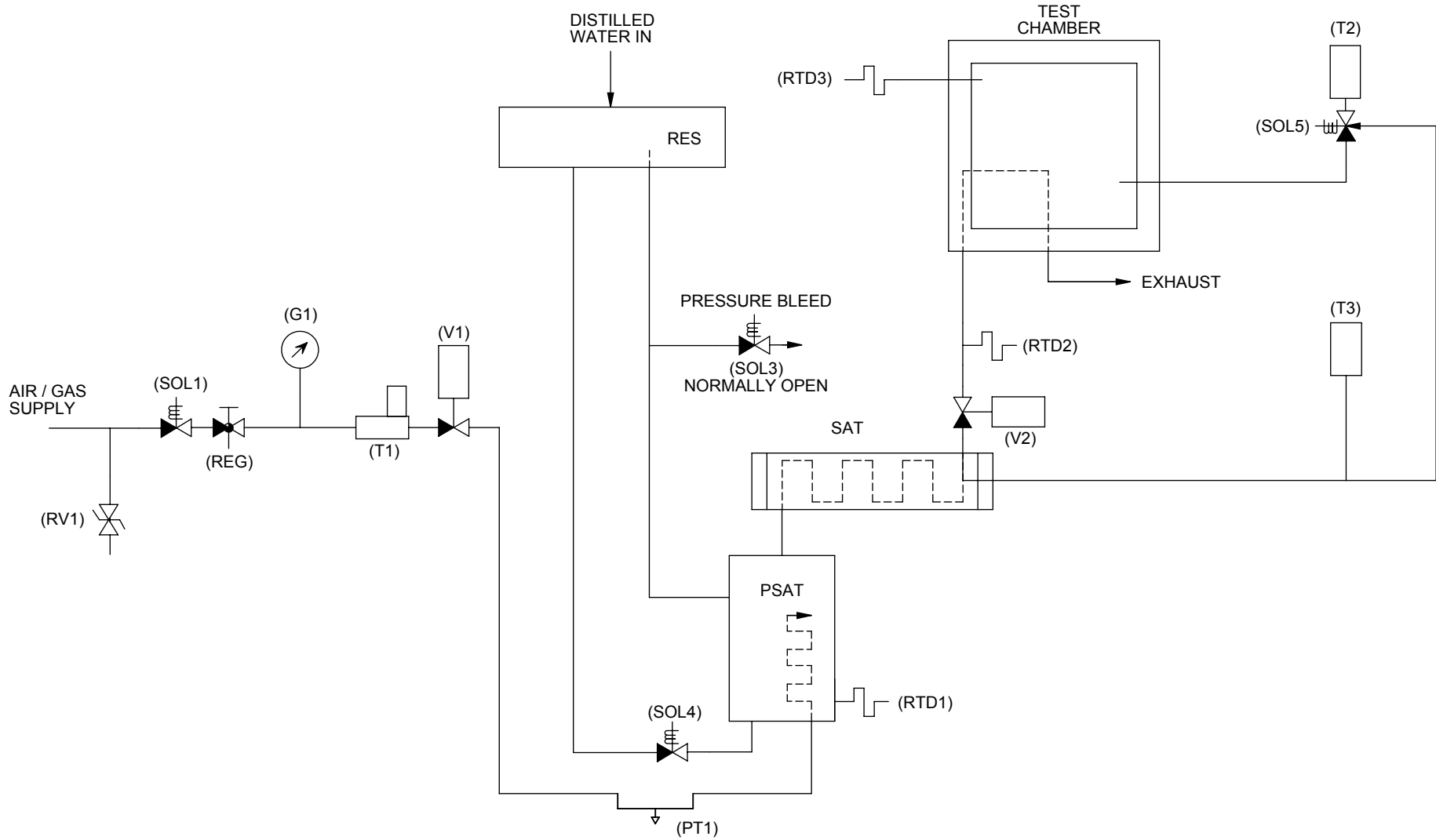

| | | | | | | | | |
|-------------|---------|---|----------------------------|---|-----------------------------------|---|--------------|--|
| | | PRODUCTION DESIGNATION 25-Z-16 | THIRD ANGLE PROJECTION | PROPRIETARY NOTICE THIS DRAWING AND INFORMATION CONTAINED WITHIN IS PROPRIETARY TO THUNDER SCIENTIFIC AND CANNOT BE COPIED OR REPRODUCED WITHOUT WRITTEN PERMISSION | | Thunder Scientific Corporation 623 Wyoming S.E. Albuquerque, NM 87123 | | |
| | | TOLERANCES .X ±.015 .XX ±.010 .XXX ±.005 ∠ ±.50° UNLESS NOTED OTHERWISE | | DRAWN LONG 6/1/1991 CHECKED <i>MG</i> 6/1/1991 ISSUED <i>MG</i> 6/1/1991 | Pneumatic System Schematic | | | |
| NEXT ASSY | USED ON | | | SIZE A | DWG. NO. 91S25916 | | REV C | |
| APPLICATION | | | | SCALE N/A | WT. N/A | SHEET 1 OF 1 | | |

| REVISIONS | | | | |
|-----------|------|-------------|-----------|----------|
| DWN | REV. | DESCRIPTION | DATE | APPROVED |
| DWF | D | Drawn to SW | 7/29/2014 | |

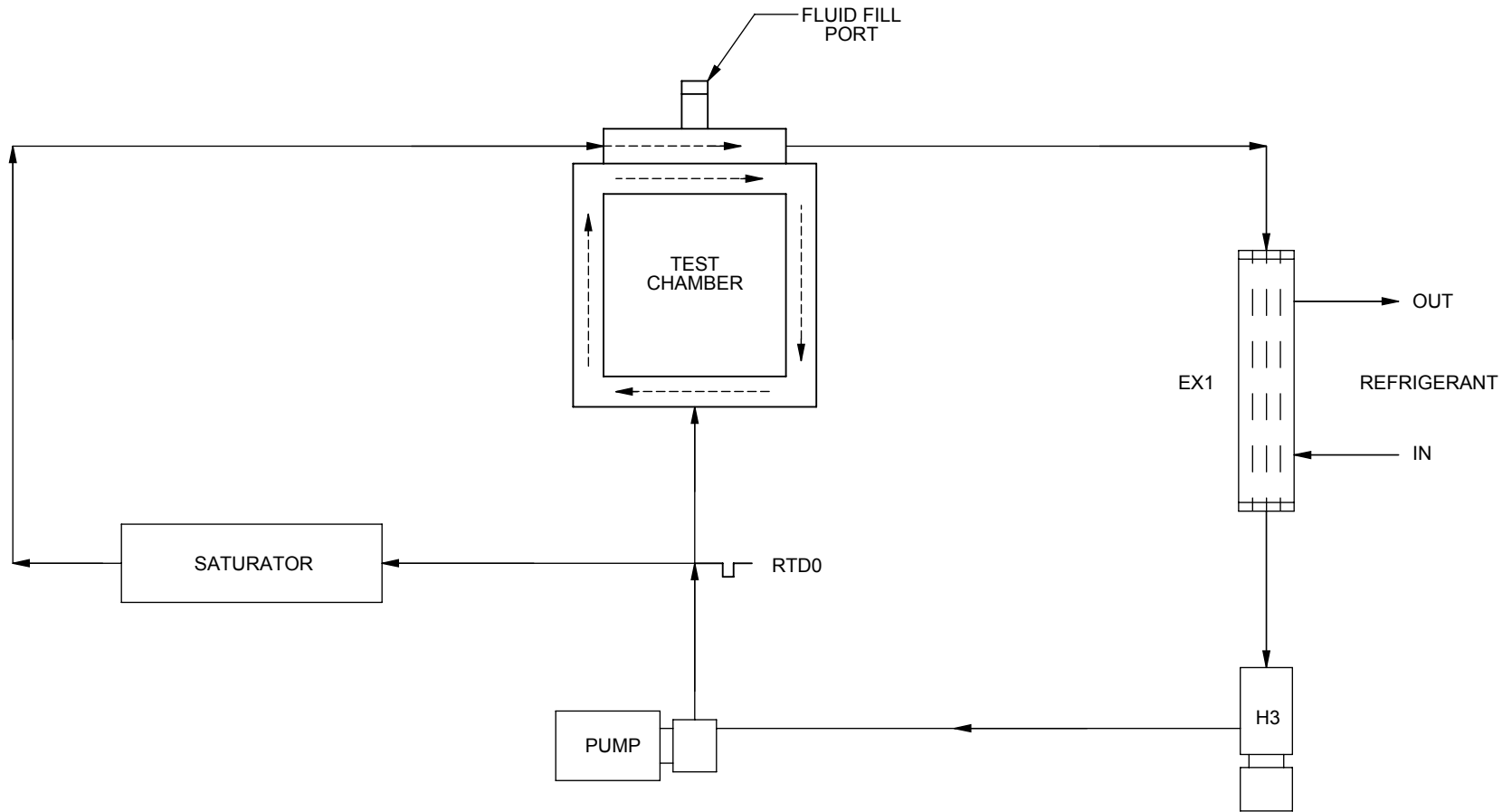

| | | | | | | | |
|-------------|---------|--|--|--|---|--------------|--|
| | | THIRD ANGLE PROJECTION | PROPRIETARY NOTICE THIS DRAWING AND INFORMATION CONTAINED WITHIN IS PROPRIETARY TO THUNDER SCIENTIFIC AND CANNOT BE COPIED OR REPRODUCED WITHOUT SPECIFIC WRITTEN PERMISSION | | Thunder Scientific Corporation 623 Wyoming S.E. Albuquerque, NM 87123 | | |
| | | | | | Heat Transfer Fluid Schematic | | |
| | 2500 | TOLERANCES .XXX ±.010 ±.50° UNLESS NOTED OTHERWISE | | DRAWN Long 6/1/1991 CHECKED <i>MG</i> 6/1/1991 ISSUED <i>MG</i> 6/1/1991 | SIZE A DWG. NO. 91S25917 | REV D | |
| NEXT ASSY | USED ON | | | SCALE: 1 : 1 | WT. N/A | SHEET 1 OF 1 | |
| APPLICATION | | | | | | | |

| REVISIONS | | | | |
|-----------|------|-------------|-----------|----------|
| DWN | REV. | DESCRIPTION | DATE | APPROVED |
| DWF | C | Drawn to SW | 7/29/2014 | |

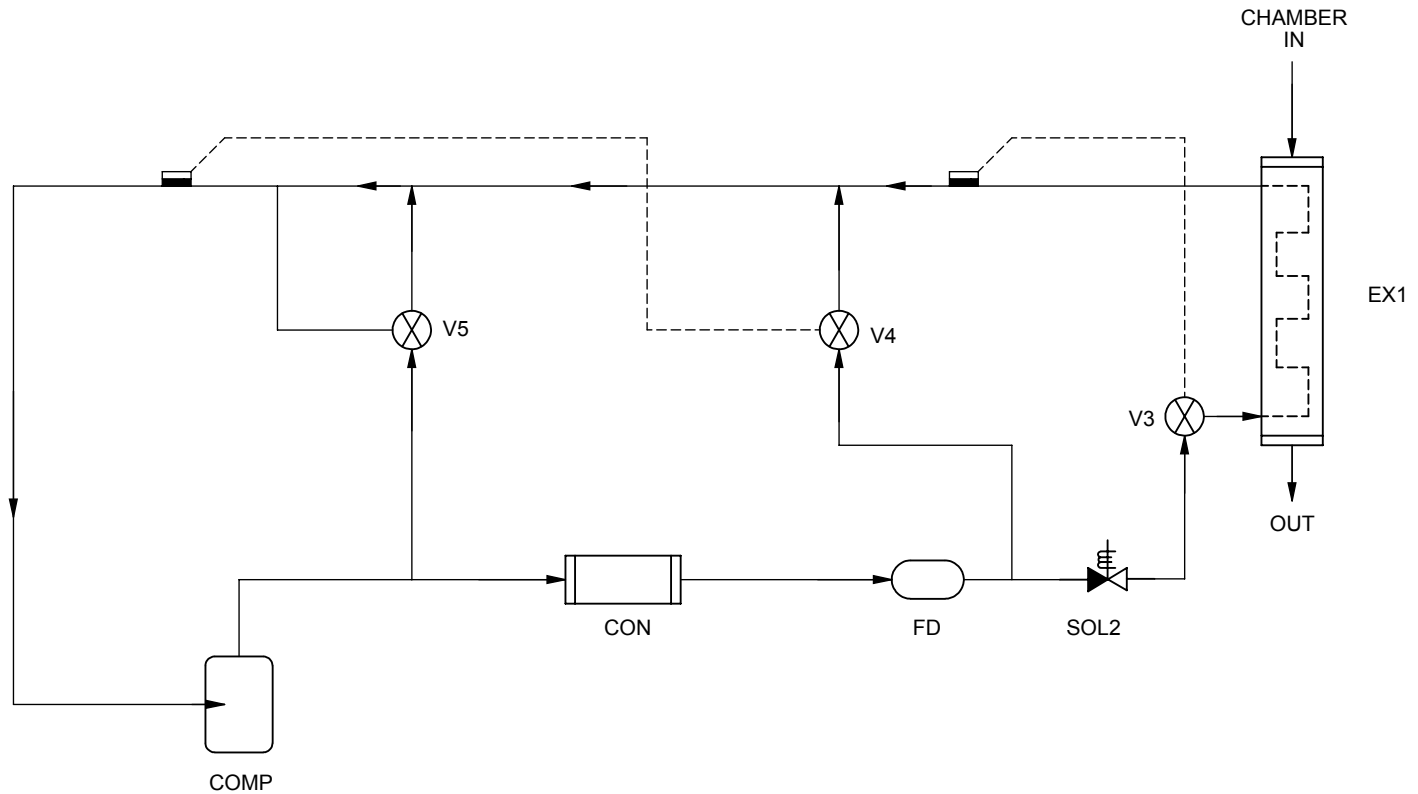

| | | | | | | | | |
|-------------|---------|------------------------|--|-----------|---|--------------|-----------------|--------------|
| | | THIRD ANGLE PROJECTION | PROPRIETARY NOTICE THIS DRAWING AND INFORMATION CONTAINED WITHIN IS PROPRIETARY TO THUNDER SCIENTIFIC AND CANNOT BE COPIED OR REPRODUCED WITHOUT SPECIFIC WRITTEN PERMISSION | | Thunder Scientific Corporation 623 Wyoming S.E. Albuquerque, NM 87123 | | | |
| | | | | | Refrigeration System Schematic | | | |
| | | TOLERANCES | DRAWN | Long | 6/1/1991 | SIZE | DWG. NO. | REV |
| | | .XXX ±.010 | CHECKED | <i>MB</i> | 6/1/1991 | A | 91S25918 | C |
| | | UNLESS NOTED OTHERWISE | ISSUED | <i>MB</i> | 6/1/1991 | SCALE: 1 : 1 | WT. N/A | SHEET 1 OF 1 |
| NEXT ASSY | USED ON | 2500 | | | | | | |
| APPLICATION | | | | | | | | |

| REVISIONS | | | | |
|-----------|------|----------------------------------|-----------|------------|
| DWN | REV. | DESCRIPTION | DATE | APPROVED |
| DWF | D | Updated to Current Configuration | 4/29/2013 | <i>MJE</i> |
| DWF | E | Updated with new ACS | 6/20/2014 | <i>MG</i> |

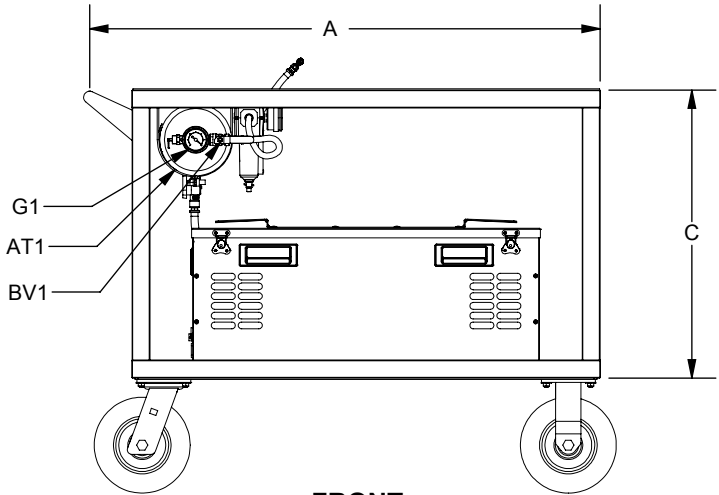

FRONT

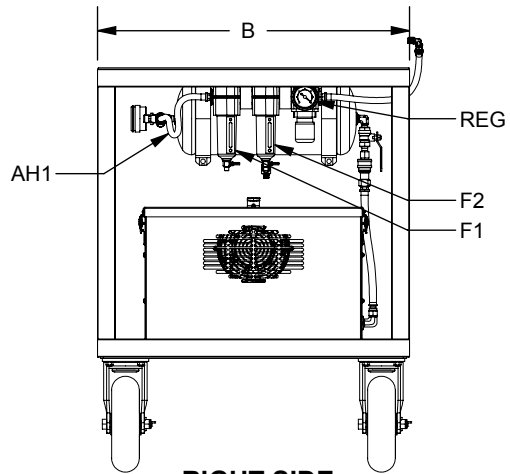

RIGHT SIDE

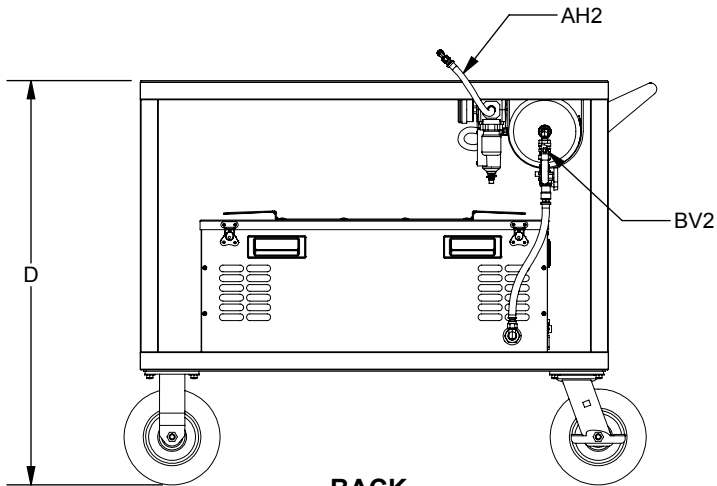

BACK

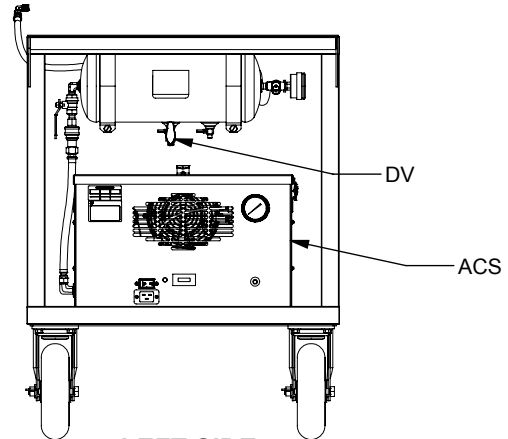

LEFT SIDE

| DIMENSIONS | | | | |
|------------|--------|--------|--------|--------|
| MODEL | A | B | C | D |
| 2500 | 40.00" | 23.00" | 24.00" | 33.25" |
| | 1.02M | 584mm | 609mm | 845mm |
| 2500 ST | 43.00" | 26.00" | 24.00" | 33.25" |
| | 1.09M | 660mm | 609mm | 845mm |

| | |
|-------------|---------|
| | |
| | |
| | 2500 |
| NEXT ASSY | USED ON |
| APPLICATION | |

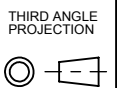

PROPRIETARY NOTICE
 THIS DRAWING AND INFORMATION CONTAINED WITHIN IS PROPRIETARY TO THUNDER SCIENTIFIC AND CANNOT BE COPIED OR REPRODUCED WITHOUT SPECIFIC WRITTEN PERMISSION

| TOLERANCES | | |
|------------------------|------------|------------|
| .XXX | ±.010 | |
| | ±.50° | |
| UNLESS NOTED OTHERWISE | | |
| DRAWN | SMITH | 11/12/1998 |
| CHECKED | <i>MG</i> | 11/12/1998 |
| ISSUED | <i>DMF</i> | 11/12/1998 |

Thunder Scientific Corporation
 623 Wyoming S.E. Albuquerque, NM 87123

| | | |
|----------------------|-----------|--------------|
| ACS with Cart Layout | | |
| SIZE | DWG. NO. | REV |
| A | 98D25919 | E |
| SCALE: 1 : 16 | WT.287.27 | SHEET 1 OF 1 |

| REVISIONS | | | | |
|-----------|------|---|-----------|------------|
| DWN | REV. | DESCRIPTION | DATE | APPROVED |
| DWF | E | Removed Muffler - Drawn to SW | 4/15/2013 | <i>MJE</i> |
| DWF | F | Replaced RV1 & COMP1 with ACS Changed RV2 to RV1 | 7/10/2014 | <i>MB</i> |

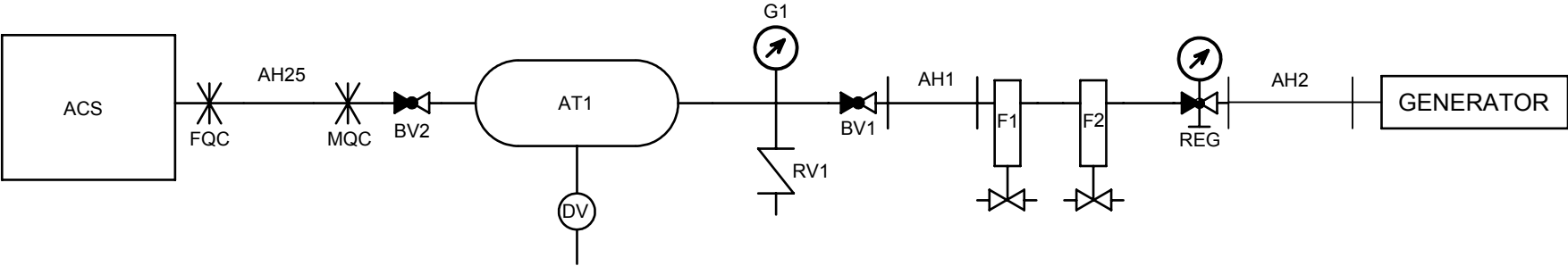

| | | | | | | | | |
|-------------|--|------------------------|------------------------|--|-----------|--|--|---------------------------------|
| | | PRODUCTION DESIGNATION | THIRD ANGLE PROJECTION | PROPRIETARY NOTICE | | Thunder Scientific Corporation | | |
| | | 25-Z-21 | | THIS DRAWING AND INFORMATION CONTAINED WITHIN IS PROPRIETARY TO THUNDER SCIENTIFIC AND CANNOT BE COPIED OR REPRODUCED WITHOUT WRITTEN PERMISSION | | 623 Wyoming S.E. Albuquerque, NM 87123 | | |
| | | TOLERANCES | | DRAWN | LONG | 6/1/1991 | | Cart Pneumatic System Schematic |
| | | .X ±.015 | | CHECKED | <i>MB</i> | 6/1/1991 | | SIZE A |
| | | .XX ±.010 | | ISSUED | <i>MB</i> | 6/1/1991 | | DWG. NO. 91S25921 |
| | | .XXX ±.005 | | | | | | REV F |
| | | ∠ ±.50° | | | | | | SCALE N/A |
| APPLICATION | | UNLESS NOTED OTHERWISE | | | | WT. N/A | | SHEET 1 OF 1 |

| REVISIONS | | | | |
|-----------|------|-------------------------------------|-----------|----------|
| DWN | REV. | DESCRIPTION | DATE | APPROVED |
| DWF | D | Added funnel assembly - Drawn to SW | 7/12/2013 | |

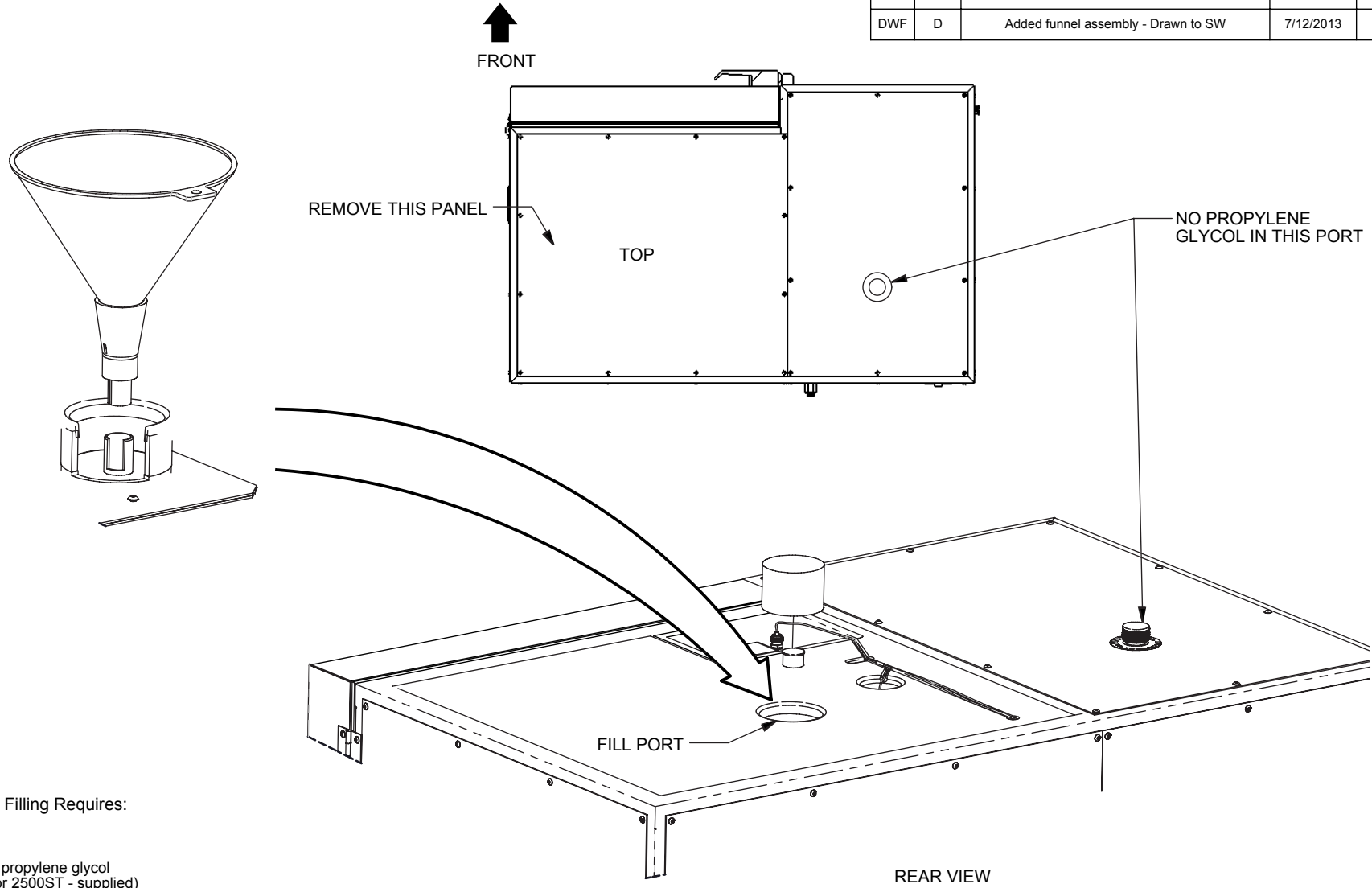

Chamber Fluid Filling Requires:

- T10 Torx Driver
- Funnel
- 3 U.S. gallons of propylene glycol
- (4 U.S. gallons for 2500ST - supplied)

CHAMBER FLUID FILLING INSTRUCTIONS

1. Remove top right console panel (panel above chamber)
2. Locate fluid fill port (under insulation and labeled "Fluid Fill Port").
3. Remove red cap and insert funnel into fluid fill port.
4. Using 3 U.S. gallons of -100° C propylene glycol mix (4 U.S. gallons for 2500ST) fill until level is approximately 1/4" below bottom of fill port, or to bottom of funnel.
5. Remove funnel and replace fluid fill port cap and insulation.
6. Replace top right console panel.
7. Chamber fluid filling is now complete.

| | | | | | | | | | |
|-------------|---------|--|---|---|------------|---|-----------------|---|----------|
| | | PRODUCTION DESIGNATION 25-Z-24 | THIRD ANGLE PROJECTION | PROPRIETARY NOTICE THIS DRAWING AND INFORMATION CONTAINED WITHIN IS PROPRIETARY TO THUNDER SCIENTIFIC AND CANNOT BE COPIED OR REPRODUCED WITHOUT WRITTEN PERMISSION | | Thunder Scientific Corporation 623 Wyoming S.E. Albuquerque, NM 87123 | | | |
| | | 2500ST | TOLERANCES .X ±.015 .XX ±.010 .XXX ±.005 \angle ±.50° UNLESS NOTED OTHERWISE | | DRAWN | FISCHER | 3/13/1997 | Chamber Fluid Filling Instructions | |
| | | 2500 | | | CHECKED | | 3/13/1997 | SIZE | DWG. NO. |
| NEXT ASSY | USED ON | | ISSUED | | 3/13/1997 | A | 97D25924 | D | |
| APPLICATION | | | | | SCALE: N/A | WT. 203.05 | SHEET 1 OF 1 | | |

| REVISIONS | | | | |
|-----------|------|--|-----------|----------|
| DWN | REV. | DESCRIPTION | DATE | APPROVED |
| DWF | E | Drawn to SW - Added ST Cart Dimensions | 7/29/2014 | |

TOP VIEW

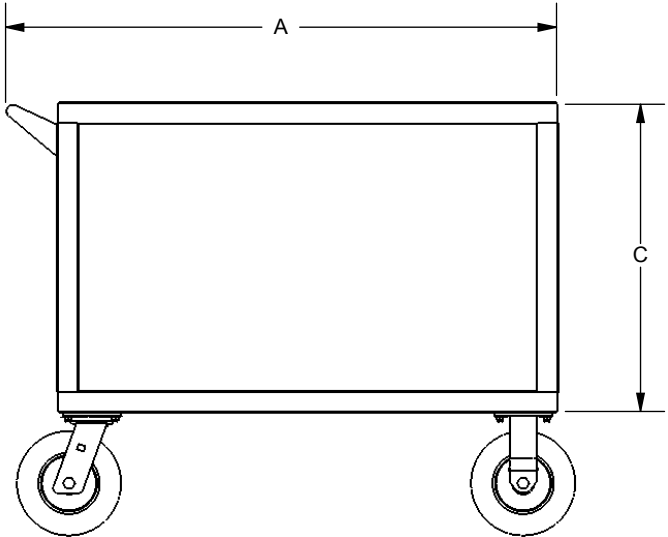

FRONT VIEW

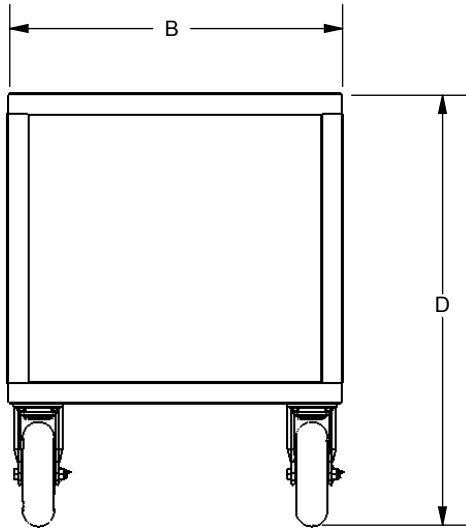

SIDE VIEW

| DIMENSIONS | | | | |
|------------|--------|--------|--------|--------|
| MODEL | A | B | C | D |
| 2500 | 40.00" | 23.00" | 24.00" | 33.25" |
| | 1.02M | 584mm | 609mm | 845mm |
| 2500 ST | 43.00" | 26.00" | 24.00" | 33.25" |
| | 1.09M | 660mm | 609mm | 845mm |

| | |
|-------------|---------|
| | |
| | |
| | |
| | 2500 |
| NEXT ASSY | USED ON |
| APPLICATION | |

THIRD ANGLE PROJECTION

PROPRIETARY NOTICE
THIS DRAWING AND INFORMATION CONTAINED WITHIN IS PROPRIETARY TO THUNDER SCIENTIFIC AND CANNOT BE COPIED OR REPRODUCED WITHOUT SPECIFIC WRITTEN PERMISSION

TOLERANCES
.XXX ±.010
/ ±.50°
UNLESS NOTED OTHERWISE

| | | |
|---------|---------|-----------|
| DRAWN | Fischer | 4/14/1997 |
| CHECKED | | 4/14/1997 |
| ISSUED | | 4/14/1997 |

Thunder Scientific Corporation
623 Wyoming S.E. Albuquerque, NM 87123

Cart Mechanical Dimensions

| | | |
|---------------|--------------------------|--------------|
| SIZE A | DWG. NO. 97D25926 | REV E |
| SCALE: 1 : 15 | | WT. 163.04 |
| SHEET 1 OF 1 | | |

| REVISIONS | | | | |
|-----------|------|-------------|-----------|----------|
| DWN | REV. | DESCRIPTION | DATE | APPROVED |
| DWF | C | Drawn to SW | 7/29/2014 | |

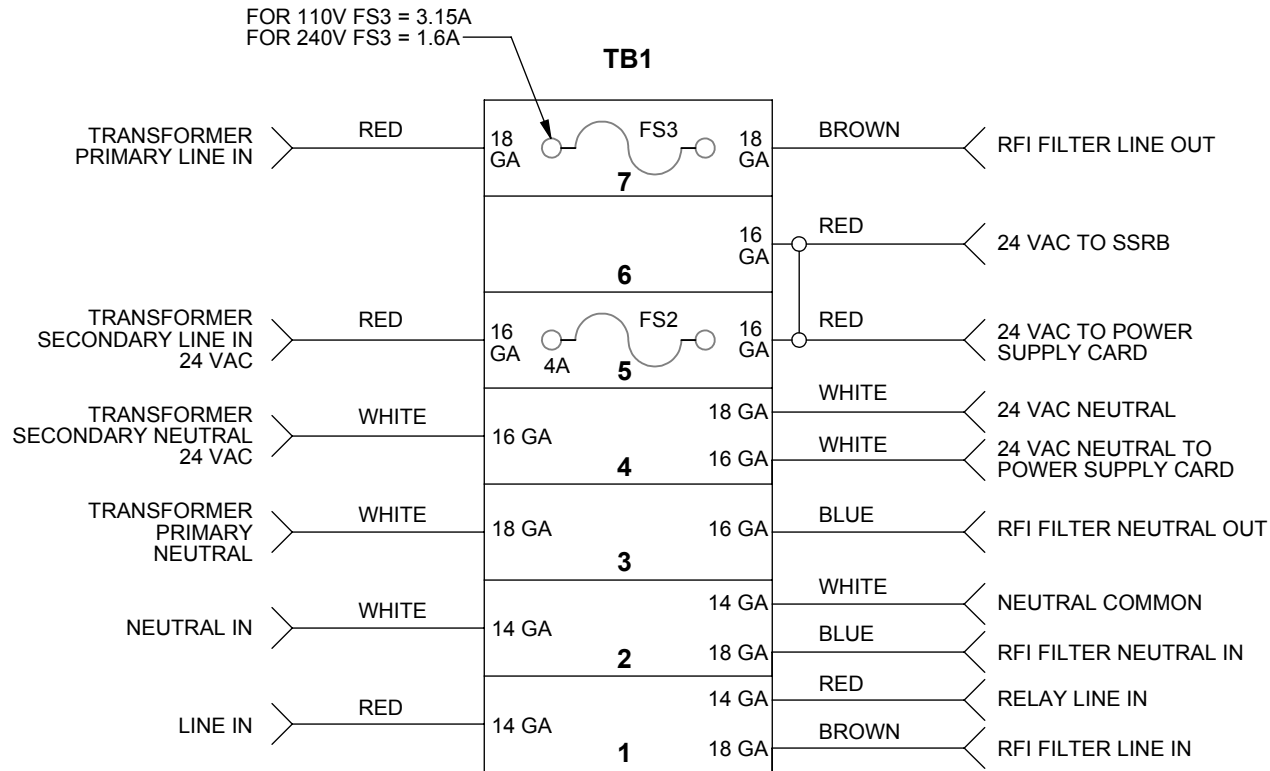

| | | | | | | | |
|-----------|---------|--|--|--|---|-------------------------------------|------------------------------|
| | | THIRD ANGLE PROJECTION | PROPRIETARY NOTICE THIS DRAWING AND INFORMATION CONTAINED WITHIN IS PROPRIETARY TO THUNDER SCIENTIFIC AND CANNOT BE COPIED OR REPRODUCED WITHOUT SPECIFIC WRITTEN PERMISSION | | Thunder Scientific Corporation 623 Wyoming S.E. Albuquerque, NM 87123 | | |
| | | | | | 2500 Fuse Upgrade Schematic | | |
| | 2500 | TOLERANCES .XXX ±.010 ±.50° UNLESS NOTED OTHERWISE | | DRAWN Furry 10/3/2008 CHECKED 12/28/2008 ISSUED 12/30/2008 | SIZE A SCALE: 1 : 1 | DWG. NO. 08S25942 WT. N/A | REV C SHEET 1 OF 1 |
| NEXT ASSY | USED ON | APPLICATION | | | | | |

REVISIONS

| DWN | REV. | DESCRIPTION | DATE | APPROVED |
|-----|------|---|-----------|-----------|
| DWF | A | Added Limit Switch - Created Manual Drawing | 6/10/2014 | <i>JB</i> |

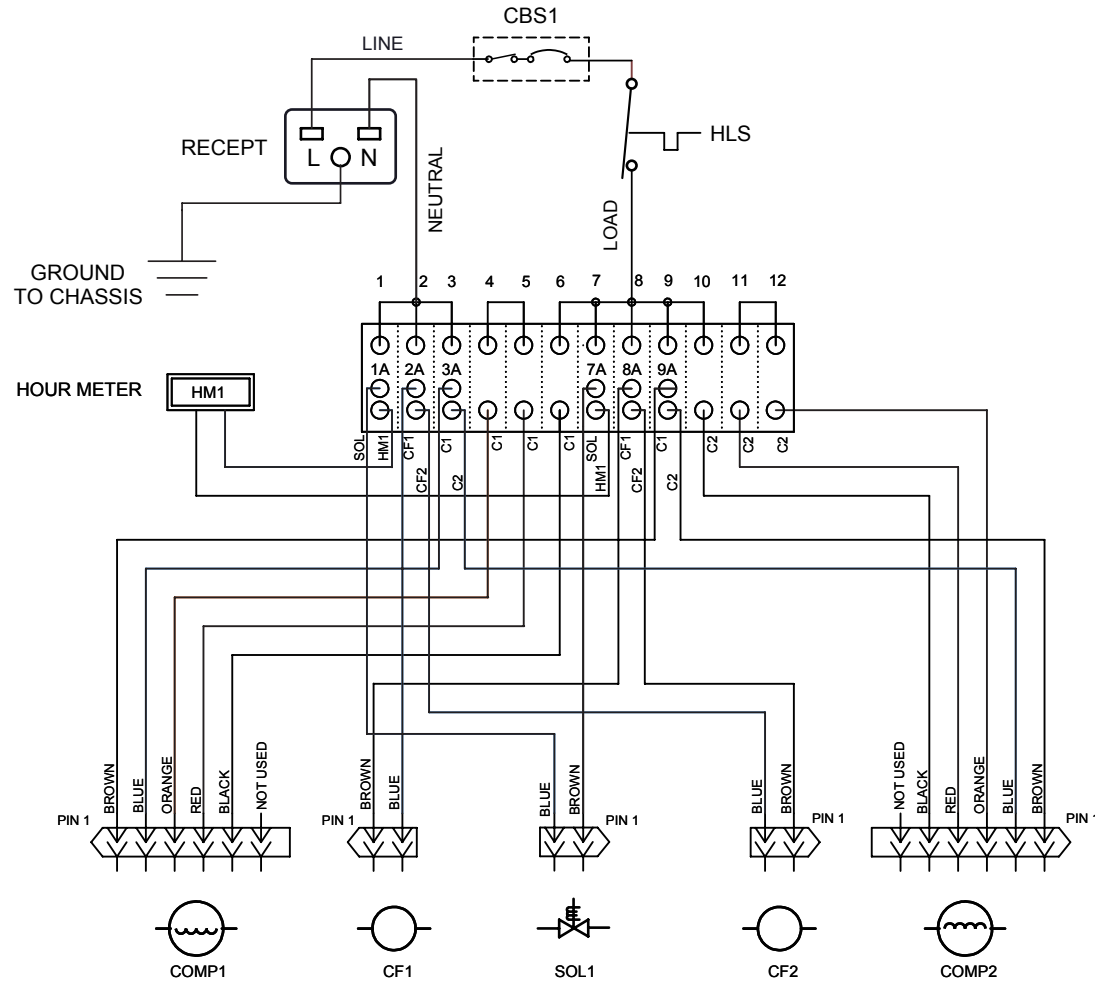

LOW VOLTAGE

| | | | | | | | | | |
|-------------|---------|------------------------|--|--|---|-------------------------|---|--|--|
| | | THIRD ANGLE PROJECTION | <p>PROPRIETARY NOTICE THIS DRAWING AND INFORMATION CONTAINED WITHIN IS PROPRIETARY TO THUNDER SCIENTIFIC AND CANNOT BE COPIED OR REPRODUCED WITHOUT SPECIFIC WRITTEN PERMISSION</p> | | <p>Thunder Scientific Corporation 623 Wyoming S.E. Albuquerque, NM 87123</p> | | | | |
| | | | <p>TOLERANCES .XXX ±.010 / ±.50° UNLESS NOTED OTHERWISE</p> | | <p>DRAWN FURRY 4/7/2014 CHECKED <i>JB</i> 4/11/2014 ISSUED <i>Dwf</i> 4/11/2014</p> | | <p>ACS Twin Electrical Schematic</p> | | |
| NEXT ASSY | USED ON | | | | SIZE A | DWG. NO. ACS2031 | REV A | | |
| APPLICATION | | | | | SCALE: N/A | WT. N/A | SHEET 1 OF 2 | | |

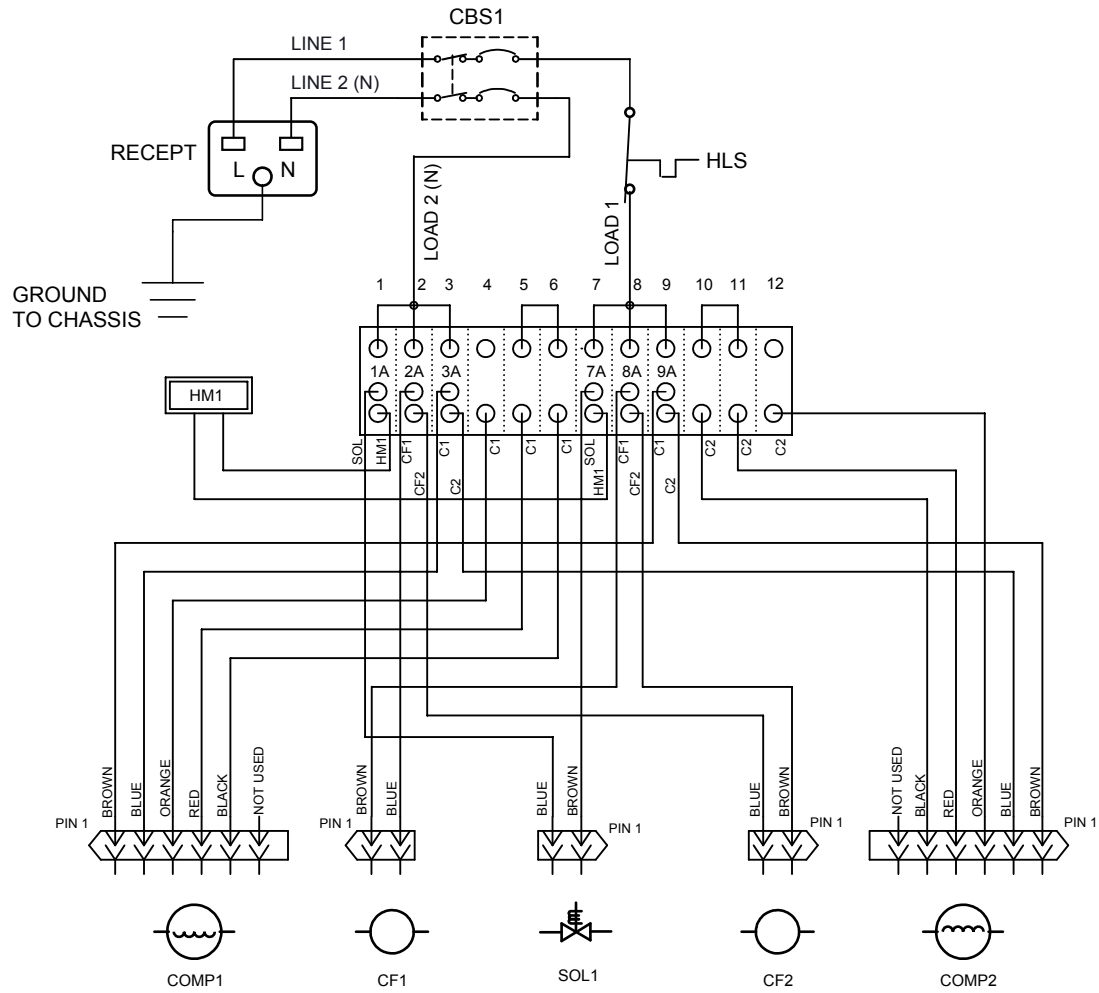

HIGH VOLTAGE

| | | | | | | | |
|-------------|---------|--|--|--|---|--------------|--|
| | | THIRD ANGLE PROJECTION | PROPRIETARY NOTICE THIS DRAWING AND INFORMATION CONTAINED WITHIN IS PROPRIETARY TO THUNDER SCIENTIFIC AND CANNOT BE COPIED OR REPRODUCED WITHOUT SPECIFIC WRITTEN PERMISSION | | Thunder Scientific Corporation 623 Wyoming S.E. Albuquerque, NM 87123 | | |
| | | | | | ACS Twin Electrical Schematic | | |
| NEXT ASSY | USED ON | TOLERANCES .XXX ±.010 ±.50° UNLESS NOTED OTHERWISE | | DRAWN FURRY 4/7/2014 CHECKED <i>BF</i> 4/11/2014 ISSUED <i>Duf</i> 4/11/2014 | SIZE A DWG. NO. ACS2031 | REV A | |
| APPLICATION | | | | SCALE: N/A | WT. N/A | SHEET 2 OF 2 | |

Read Actual Values



| | |
|----------------------|--|
| Description | Returns the current generated system values. |
| Prerequisites | Requires Benchtop firmware revision 1.05 or greater. |
| Syntax | ? |
| Parameters | None |
| Remarks | <u>Data Returned</u> |

? returns a list of 8 comma separated values indicating the current data and status of the system. These values are returned in the same order as they appear on the Benchtop screen and **always** in the units listed below. The following represents the values in the sequence:

| <u>ITEM</u> | <u>DESCRIPTION</u> |
|-------------|----------------------------|
| 1 | %RH @Pc |
| 2 | %RH @PcTc |
| 3 | Saturation Pressure, psia |
| 4 | Chamber Pressure, psia |
| 5 | Saturation Temperature, °C |
| 6 | Chamber Temperature, °C |
| 7 | Flow Rate, l/m |
| 8 | System Status |

The System Status parameter (item 8 above) indicates whether or not the system is currently generating (running). The 2 possible returned values are as follows:

| <u>VALUE</u> | <u>DESCRIPTION</u> |
|--------------|--------------------|
| 0 | System is stopped |
| 1 | System in running |

Examples

The ? command is used to request the current generated system values and status:

computer sends ?<CR>
benchtop responds 19.93,20.00,61.22,12.13,21.11,21.12,14.95,1<CR><LF>

The data returned indicates that the system is currently running (last item in the list=1), and the generated values are:

%RH @Pc = 19.93
%RH @PcTc = 20.00
Sat Pressure = 61.22 psia
Chamber Pressure = 12.13 psia
Sat Temperature = 21.11°C
Chamber Temperature = 21.12°C
Flow Rate = 14.95 l/m

Read Setpoints

?SP

| Description | Returns the current system Setpoints and operating mode. | | | | | | | | | | | | | | | | | | | | | | |
|----------------------|---|-------------|--------------------|---|------------------|---|--------------------|---|------------------------------------|---|-------------------------------------|---|-------------------------|---|-----------------------------------|-------------|--------------------|---|----------------------------|---|------------------------------|---|--|
| Prerequisites | Requires Benchtop firmware revision 1.05 or greater. | | | | | | | | | | | | | | | | | | | | | | |
| Syntax | ?SP | | | | | | | | | | | | | | | | | | | | | | |
| Parameters | None | | | | | | | | | | | | | | | | | | | | | | |
| Remarks | <p><u>Data Returned</u></p> <p>?SP returns a list of 6 comma separated values indicating the current setpoints and operating mode of the system. These values are returned in the same order as they appear on the Benchtop screen and always in the units listed below. The following represents the values in the sequence:</p> <table><thead><tr><th><u>ITEM</u></th><th><u>DESCRIPTION</u></th></tr></thead><tbody><tr><td>1</td><td>%RH @Pc setpoint</td></tr><tr><td>2</td><td>%RH @PcTc setpoint</td></tr><tr><td>3</td><td>Saturation Pressure setpoint, psia</td></tr><tr><td>4</td><td>Saturation Temperature setpoint, °C</td></tr><tr><td>5</td><td>Flow Rate setpoint, l/m</td></tr><tr><td>6</td><td>Current control mode (1, 2, or 3)</td></tr></tbody></table> <p>The control mode parameter (item 6 above) indicates which of the 3 possible parameters the system is set to control on. The control modes are as follows:</p> <table><thead><tr><th><u>MODE</u></th><th><u>DESCRIPTION</u></th></tr></thead><tbody><tr><td>1</td><td>System controls on %RH @Pc</td></tr><tr><td>2</td><td>System controls on %RH @PcTc</td></tr><tr><td>3</td><td>System controls on Saturation Pressure</td></tr></tbody></table> | <u>ITEM</u> | <u>DESCRIPTION</u> | 1 | %RH @Pc setpoint | 2 | %RH @PcTc setpoint | 3 | Saturation Pressure setpoint, psia | 4 | Saturation Temperature setpoint, °C | 5 | Flow Rate setpoint, l/m | 6 | Current control mode (1, 2, or 3) | <u>MODE</u> | <u>DESCRIPTION</u> | 1 | System controls on %RH @Pc | 2 | System controls on %RH @PcTc | 3 | System controls on Saturation Pressure |
| <u>ITEM</u> | <u>DESCRIPTION</u> | | | | | | | | | | | | | | | | | | | | | | |
| 1 | %RH @Pc setpoint | | | | | | | | | | | | | | | | | | | | | | |
| 2 | %RH @PcTc setpoint | | | | | | | | | | | | | | | | | | | | | | |
| 3 | Saturation Pressure setpoint, psia | | | | | | | | | | | | | | | | | | | | | | |
| 4 | Saturation Temperature setpoint, °C | | | | | | | | | | | | | | | | | | | | | | |
| 5 | Flow Rate setpoint, l/m | | | | | | | | | | | | | | | | | | | | | | |
| 6 | Current control mode (1, 2, or 3) | | | | | | | | | | | | | | | | | | | | | | |
| <u>MODE</u> | <u>DESCRIPTION</u> | | | | | | | | | | | | | | | | | | | | | | |
| 1 | System controls on %RH @Pc | | | | | | | | | | | | | | | | | | | | | | |
| 2 | System controls on %RH @PcTc | | | | | | | | | | | | | | | | | | | | | | |
| 3 | System controls on Saturation Pressure | | | | | | | | | | | | | | | | | | | | | | |
| Examples | <p>The ?SP command is used to request the system setpoints and control mode:</p> <p>computer sends ?SP<CR> benchtop responds <i>20.14 , 20 , 74.27 , 21.11 , 15 , 2</i><CR><LF></p> <p>The data returned indicates that the setpoints are:</p> <p>%RH @Pc = 20.14 %RH @PcTc = 20.00 (also the control mode) Sat Pressure = 74.27 psia Sat Temperature = 21.11°C Flow Rate = 15 l/m</p> <p>and the Control Mode = 2 (%RH @PcTc)</p> | | | | | | | | | | | | | | | | | | | | | | |

Read Run Status

?RUN

| Description | Returns the current system operating status. | | | | | | |
|----------------------|---|--------------|--------------------|---|-------------------|---|-------------------|
| Prerequisites | Requires Benchtop firmware revision 1.05 or greater. | | | | | | |
| Syntax | ?RU ?RUN | | | | | | |
| Parameters | None | | | | | | |
| Remarks | <p><u>Data Returned</u></p> <p>?RU returns one of two values to indicate whether or not the system is currently generating (running). The 2 possible returned values are as follows:</p> <table><thead><tr><th><u>VALUE</u></th><th><u>DESCRIPTION</u></th></tr></thead><tbody><tr><td>0</td><td>System is stopped</td></tr><tr><td>1</td><td>System in running</td></tr></tbody></table> | <u>VALUE</u> | <u>DESCRIPTION</u> | 0 | System is stopped | 1 | System in running |
| <u>VALUE</u> | <u>DESCRIPTION</u> | | | | | | |
| 0 | System is stopped | | | | | | |
| 1 | System in running | | | | | | |
| Examples | <p>The ?RU command is used to request the current system status:</p> <p>computer sends <i>benchtop responds</i></p> <pre>?RU<CR> 0<CR><LF></pre> <p>The "0" returned indicates that the system is currently stopped.</p> | | | | | | |

Read Error Number

?ER

| | |
|----------------------|---|
| Description | Returns the current error number relating to system shutdown. |
| Prerequisites | Requires Benchtop firmware revision 1.05 or greater. |
| Syntax | ?ER |
| Parameters | None |
| Remarks | <u>Data Returned</u> |

?ER returns one of several values indicating the reason(s) that the system shut down. The value returned can be any one, or an algebraic combination, of several of the following:

| <u>VALUE</u> | <u>DESCRIPTION</u> |
|--------------|--|
| 0 | No error |
| 1 | Expansion Valve not closing |
| 2 | Flow Valve not Closing |
| 4 | No Supply Pressure |
| 8 | Reservoir Needs Water |
| 16 | PreSat Water Empty |
| 32 | Low Pressure Underrange |
| 64 | Low Pressure Overage (Chamber Pressure) |
| 128 | High Pressure Underrange |
| 256 | High Pressure Overage |
| 288 | Pressure Transducer Failure |
| 320 | Low Pressure Overage (Saturation Pressure) |
| 480 | Pressure Transducer Misalignment |
| 16896 | Saturation Temperature Underrange |
| 17408 | Presaturator Temperature Underrange |
| 18432 | Expansion Valve Temperature Underrange |
| 20480 | Chamber Temperature Underrange |
| 24576 | Reference Temperature Underrange |
| -16384 | Cabinet Temperature Overage |
| -24576 | Reference Temperature Overage |
| -28672 | Chamber Temperature Overage |
| -30720 | Expansion Valve Temperature Overage |
| -31744 | Presaturator Temperature Overage |
| -32256 | Saturation Temperature Overage |
| -32768 | Temperature Overage |

Examples

After an unexpected system shutdown (indicated by the value returned from the ?RU command or the last parameter in the ? command), the ?ER command is used to determine the nature of the failure:

computer sends
benchtop responds

```
?ER<CR>  
4<CR><LF>
```

The "4" returned indicates that the system lost supply pressure.

Cabinet Fan Temperature

?TF

| | |
|----------------------|--|
| Description | Returns the cabinet fan temperature in °C. |
| Prerequisites | Requires Benchtop firmware revision 1.05 or greater. |
| Syntax | ?TF |
| Parameters | None |
| Remarks | <u>Data Returned</u> ?TF returns the value (in whole °C only) of the cabinet fan temperature. |
| Examples | The ?TF command is used to read the current cabinet temperature. computer sends <i>benchtop responds</i> ?TF<CR> 30<CR><LF> The system indicates that the current measured cabinet temperature is 30°C. At this temperature, the cabinet fan should be running. |

Start the System

RUN

| | |
|----------------------|--|
| Description | Starts the system just as if the front panel "RUN" key had been pressed. |
| Prerequisites | None. |
| Syntax | RUN |
| Parameters | None |
| Remarks | <u>Data Returned</u> None. The only response is a carriage return/linefeed terminator. |
| Examples | The RUN command is used to start the system. computer sends <i>benchtop responds</i> RUN <CR> <CR><LF> The <CR><LF> response will be delayed several seconds until the system start-up is complete. |

Stop the System

STOP

Description Stops the system just as if the front panel "STOP" key had been pressed.

Prerequisites None.

Syntax **STO**
STOP

Parameters None

Remarks Data Returned

None. The only response is a carriage return/linefeed terminator.

Examples The **STOP** command is used to stop a running system.

computer sends
benchtop responds

STOP<CR>
<CR><LF>

The <CR><LF> response will be delayed several seconds until the system shutdown is complete.

Description

Sends one line of data, in the units currently displayed on the control screen, to a printer, if connected to the Benchtop's printer port, just as if the front panel <•> key had been pressed.

Prerequisites

The system must be running, and the serial port parameters must match between the Benchtop and the printer used. See section 3.3.2.6 Printer Port Parameters of the Benchtop Operations Manual to review and edit parameters.

Syntax

PRI
PRINT

Parameters

None

Remarks

Data Returned

None. The only response is a carriage return/linefeed terminator. If the system is not running, or no printer is connected, printing will not take place, but the carriage return/linefeed terminator will still be sent back.

Examples

The **PRINT** command is used to send a line of data to the printer which is connected to the Benchtop.

computer sends
benchtop responds

PRI<CR>
<CR><LF>

The <CR><LF> response completion of the command even if the system is currently stopped or no printer is connected.

Change RH @Pc Setpoint

R1=

| | |
|--------------------------------------|---|
| Description | Changes the RH @Pc setpoint to a given value. |
| Prerequisites | Requires Benchtop firmware revision 1.05 or greater. |
| Syntax | R1= <i>setpoint</i> |
| Parameters <i>setpoint</i> | The <i>setpoint</i> value is the %RH that the system should generate. |
| Remarks | <u>Control Mode Changed</u> Sending R1= <i>setpoint</i> also changes the control mode to %RH @Pc (mode 1). In this mode, the %RH @PcTc and Saturation Pressure setpoints vary as system temperatures and pressures change. <u>Data Returned</u> None. The only response is a carriage return/linefeed terminator. |
| Examples | The R1= <i>setpoint</i> command is used to set the %RH @Pc to 90%RH. computer sends <i>benchtop responds</i> R1=90 <CR> <CR><LF> The <CR><LF> response signifies completion of the command. |

Change RH @PcTc Setpoint

R2=

Description

Changes the RH @PcTc setpoint to a given value.

Prerequisites

Requires Benchtop firmware revision 1.05 or greater.

Syntax

R2=*setpoint*

Parameters

setpoint

The *setpoint* value is the %RH that the system should generate.

Remarks

Control Mode Changed

Sending **R2=***setpoint* also changes the control mode to %RH @PcTc (mode 2). In this mode, the %RH @Pc and Saturation Pressure setpoints vary as system temperatures and pressures change.

Data Returned

None. The only response is a carriage return/linefeed terminator.

Examples

computer sends
benchtop responds

The **R2=***setpoint* command is used to set the %RH @PcTc to 85%RH.

R2=85<CR>
<CR><LF>

The <CR><LF> response signifies completion of the command.

Change Saturation Pressure Setpoint **PS=**

| | |
|--------------------------------------|--|
| Description | Changes the Saturation Pressure setpoint to a given value. |
| Prerequisites | Requires Benchtop firmware revision 1.05 or greater. |
| Syntax | PS= <i>setpoint</i> |
| Parameters <i>setpoint</i> | The <i>setpoint</i> value is the Saturation Pressure, in psia only , that the system should control at. |
| Remarks | <p><u>Control Mode Changed</u></p> <p>Sending PS=<i>setpoint</i> also changes the control mode to Saturation Pressure (mode 3). In this mode, the %RH @Pc and %RH @PcTc setpoints vary as system temperatures and chamber pressure change.</p> <p><u>Data Returned</u></p> <p>None. The only response is a carriage return/linefeed terminator.</p> |
| Examples | <p>The PS=<i>setpoint</i> command is used to set the Saturation Pressure to 121.44 psia.</p> <p>computer sends <i>benchtop</i> responds</p> <p>PS=121.44<CR> <CR><LF></p> <p>The <CR><LF> response signifies completion of the command.</p> |

Change Saturation Temp Setpoint

TS=

| | |
|--------------------------------------|--|
| Description | Changes the Saturation Temperature setpoint to a given value. |
| Prerequisites | Requires Benchtop firmware revision 1.05 or greater. |
| Syntax | TS= <i>setpoint</i> |
| Parameters <i>setpoint</i> | The <i>setpoint</i> value is the Saturation Temperature, in °C only , that the system should control at. |
| Remarks | <p><u>Precautions</u></p> <p>Chamber temperature follows Saturation Temperature. When increasing Saturation Temperature, always do so at low humidity so as to prevent condensation on cool devices within the chamber. Allow time for temperatures of the devices to rise before raising humidity.</p> <p><u>Data Returned</u></p> <p>None. The only response is a carriage return/linefeed terminator.</p> |
| Examples | <p>The TS=<i>setpoint</i> command is used to set the Saturation Temperature to 10°C.</p> <p>computer sends <i>benchtop responds</i></p> <p>TS=10<CR> <CR><LF></p> <p>The <CR><LF> response signifies completion of the command.</p> |

Change Flow Rate Setpoint

FS=

| | |
|---|--|
| Description | Changes the Flow Rate setpoint to a given value. |
| Prerequisites | Requires Benchtop firmware revision 1.05 or greater. |
| Syntax | FS=<i>setpoint</i> |
| Parameters <i>setpoint</i> | The <i>setpoint</i> value is the Flow rate, in l/m only , that the system should control at. |
| Remarks | <u>Data Returned</u> None. The only response is a carriage return/linefeed terminator. |
| Examples computer sends <i>benchtop responds</i> | The FS=<i>setpoint</i> command is used to set the Flow Rate to 15 l/m. FS=15<CR> <CR><LF> The <CR><LF> response signifies completion of the command. |

System Authorization Code:

[2500]

This code was designed to prevent unauthorized personnel access to the calibration coefficients.

THUNDER SCIENTIFIC CORPORATION
623 Wyoming Blvd. SE ↗ Albuquerque NM 87123-3198
www.thunderscientific.com